

ARCTIKO INT ULUF 550

true cooling specialists



HIGHLY RELIABLE ULTRA LOW TEMPERATURE FREEZER I

The ULUF 550 Ultra low temperature freezer comes with single cooling technology that offers direct cooling and excellent cooling performance.

► MOST RELIABLE FREEZING

The single compressor technology provides reliable low temperature freezing and high temperature uniformity.

With the unique single compressor technology the freezer can reach -86 °C with only one compressor.

This is made possible through our special dimensions of the cooling system and our patented refrigerant.

With direct cooling of each compartment you achieve maximum uniformity and minimum recovery time.

► WORKING ENVIROMENT

By placing the compressor and other heat and noise generating components on the top of the unit the heat is distributed up- and backwards preventing the heat from warming up the entire room.

This design also means that there is never a compartment that you will have difficulties overlooking or using fully. Ensuring a ergonomically correct unit which is easy and pleasant to use.

► FILTERLESS CONSTRUCTION

Our filterless construction makes cleaning unnecessary. The evaporator coils are spaced so far apart that dust will not be trapped and obstruct the airflow.

With our compressors located on the top, the dust intake is minimal this eliminating the need for filters entirely, saving you maintenance time and cost.



ULUF 550*



SINGLE COMPRESSOR SYSTEM



DIRECT COOLING



FILTERLESS CONSTRUCTION



The user friendly G214 controller is standard for the ULUF 550.

It includes different alarms as visual, acoustic, open door and more.



Insulated inner door for better recovery time after door openings and optimal temperature stability.



Key lock is a standard feature in our ULUF 550. Placed on side of door for optimal security for your samples.

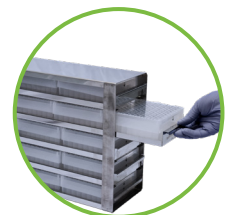

Optimal storage capacity and overview of the stored samples with the stainless steel front rack storage system

* The pictures shown are for reference only, actual product size may vary. Please read the dimensions of the product in the specifications.

ARCTIKO^{INT} ULUF 550

true cooling specialists

MAIN DIMENSIONS

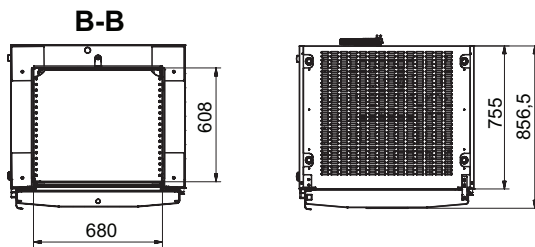
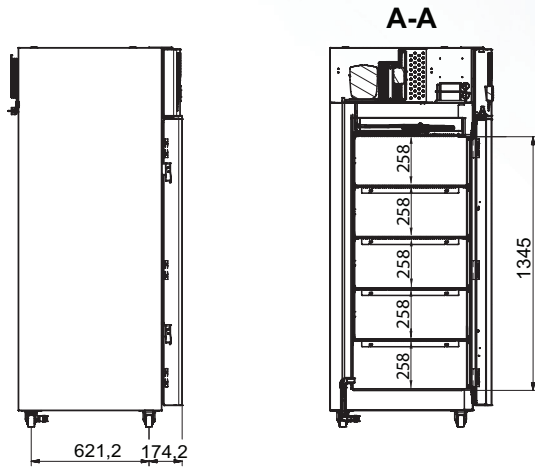
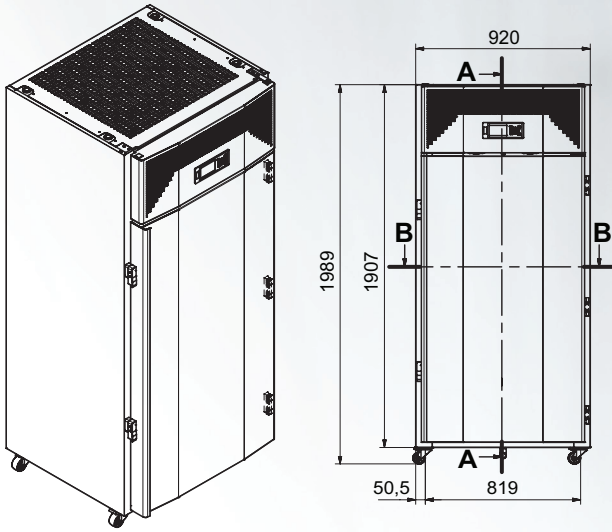

The ARCTIKO ULUF 550 model supports following optional features:

- Modbus adaptor for G214 controller
- Temperature chart recorder
- CO₂ back-up system
- GSM alarm module
- Voltage converter
- Voltage stabilizer
- Racks & Boxes
- Cryo gloves

OPTIONAL FEATURES

CERTIFICATES

ISO
ISO 9001:2015
Certificate No: 33037

ISO
ISO 13485:2016
Certificate No: 10000320341-PA-NA-NOR



MODEL	ULUF 550-2M
Item code	US-DAI 1375-1
Temperature range (°C)	-40 / -86
Temperature range (°F)	-40 / -123
Max. ambient temperature (°C)	25
Max. ambient temperature (°F)	77
Capacity (L)	556
Capacity (cu. ft.)	19,6
Exterior dimensions WxDxH (mm)	920x906x1990
Exterior dimensions WxDxH (inches)	36,22x35,67x78,35
Interior dimensions WxDxH (mm)	680x608x1345
Interior dimensions WxDxH (inches)	26,78x23,94x52,95
Weight (kg)	208
Weight (lbs)	459
Insulation (mm)	120
Insulation (inches)	4,7
Cooling technology	single system / static
Controller model / probe type	G214 / PT1000
Power	
Power supply (V)	110
Frequency (Hz)	60
Power consumption (kWh/24h)	16,3
AMP (A)	11,5
Power (Watt)	820
Horse power (HP)	3/4
Alarm functions	
Alarm display as text - not codes	yes
Visual / acoustic alarm	yes / yes
Power failure alarm	yes
Adjustable high / low temperature alarm	yes / yes
Open door alarm	yes
Probe failure alarm	yes
Low battery alarm	yes
Compressor failure alarm	no
Battery backup for alarms (approx. hrs.)	72
Data logging & external connection	
Voltage free contact for remote alarm (e.g. GSM alarm module)	yes
Electronic data logger	yes
RS 485 port	yes
USB port for software update & data download	yes
Temperature chart recorder	optional
Display features	
Display type	4,3" with touch buttons
Number of optional reference probes	2
Password protection for turning unit on / off	yes
Temperature graph on display	yes
Other features	
Automatic defrost	no
Vacuum release port	yes
Access port for external probe etc. (int. diameter mm)	no
Access port for external probe etc. (int. diameter inches)	no
Light	yes
Lock with key	yes
Castors (total pcs) / castors with brake (pcs)	4 / 2
Fixed feet (pcs) / levelling feet (pcs)	no
Sub lids / inner doors (pcs)	5
Reversible door(s)	no
Fixed shelves (pcs) / adjustable shelves (pcs)	4 / 0
Max. load per shelf (kg)	30
Max. load per shelf (lbs)	66
Total capacity of 50 mm / 2 inch boxes (pcs)	320
Total capacity of 75 mm / 3 inch boxes (pcs)	240
Total capacity of 96 mm / 3,8 inch boxes (pcs)	160
Refrigeration & cabinet	
Number of compressors	1
Refrigerant	EP88
Interior cabinet material	stainless steel
Exterior cabinet material	electrogalvanized steel
Colour (exterior cabinet)	white
Foam type	polyurethane
VIP vacuum insulated panels	no
Shipping	
Shipping weight (kg)	331
Shipping weight (lbs)	730
Shipping dimensions WxDxH (cm)	103x108x219
Shipping dimensions WxDxH (inches)	40,6x42,5x86,2
Shipping volume (m ³)	2,44
Shipping volume (cu. ft.)	86,17

Actual performance of products may vary upon various factors. All rights to this temperature mapping belong to Arctiko A/S. The drawing may not be copied nor presented to any other person without prior written consent of Arctiko A/S. We reserve the right to change specifications without notice. Subject to confirmation, availability and errors. Individual ULUF units may vary and power consumption depends on loading and operating conditions. Freezer set point -80 °C, ambient temp. 25 °C, unloaded, 110V 60Hz power supply.