

ARCTIKO INT ULUF 15

true cooling specialists



ULTRA LOW TEMPERATURE BENCHTOP FREEZER I

COMPACT SPACE-SAVING DESIGN AND LOW NOISE LEVEL

The perfect storage solution for your personal laboratory. It is perfect as a benchtop model due to the small size and weight.

► COOLING TECHNOLOGY

The small size is achieved by utilizing Arctiko's special single compressor technology.

The single compressor technology is specially designed to reduce the number of mechanical components that generates unnecessary heat and noise.

It comes with the same advantages as regular sized -86°C from Arctiko and is best in class in cooling performance.

► FILTERLESS CONSTRUCTION

Our filter less construction makes cleaning unnecessary. The evaporator coils are spaced so far apart that dust will not be trapped and obstruct the airflow.

With our unique construction, the dust intake is minimal, which eliminates the need for filters entirely, saving you maintenance time and cost.

► THE OPTIMAL CHOICE

Despite its small size og the ULUF 15, you will get a very reliable ultra low freezer. If the need for samples is minimal, then this is the ultimate freezer.

By choosing a ULUF 15 there will be maximum savings on footprint because of its compact space saving design and a great energy saving compared to other larger units.



ULUF 15*



The user friendly G214 controller standard for the ULUF 15. It includes different alarms as visual, acoustic, open door and more.



Easy overview of samples with boxes.



Key lock is a standard feature in our ULUF 15. Placed on side of door for optimal security for your samples.



SINGLE COMPRESSOR SYSTEM



DIRECT COOLING



FILTERLESS CONSTRUCTION

* The pictures shown are for reference only, actual product size may vary. Please read the dimensions of the product in the specifications.

ARCTIKO INT ULUF 125

true cooling specialists

MAIN DIMENSIONS

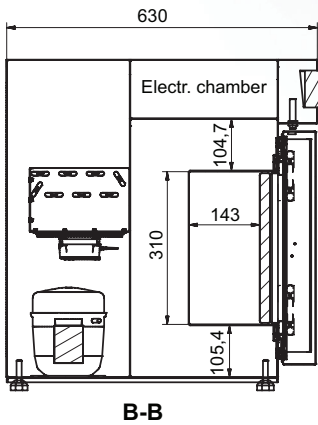
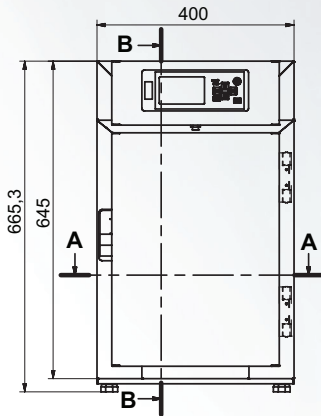

B-B

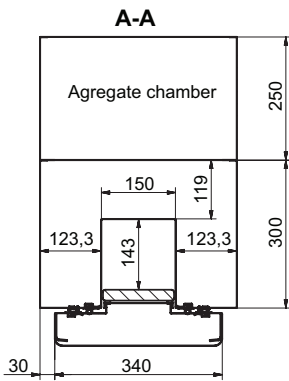

A-A

The ARCTIKO ULUF 15 model supports following optional features:

- Modbus adaptor for G214 controller
- GSM alarm module
- Voltage converter
- Voltage stabilizer
- Boxes
- Cryo gloves

OPTIONAL FEATURES

CERTIFICATES



MODEL	ULUF 15
Item code	US-DAI 1390
Temperature range (°C)	-40 / -86
Temperature range (°F)	-40 / -123
Max. ambient temperature (°C)	25
Max. ambient temperature (°F)	77
Capacity (L)	7
Capacity (cu. ft.)	0,3
Exterior dimensions WxDxH (mm)	400x630x665
Exterior dimensions WxDxH (inches)	15,75x24,80x26,18
Interior dimensions WxDxH (mm)	150x143x310
Interior dimensions WxDxH (inches)	5,91x5,63x12,20
Weight (kg)	63
Weight (lbs)	139
Insulation (mm)	120
Insulation (inches)	4,7
Cooling technology	single system / static
Controller model / probe type	G214 / PT1000
Power	
Power supply (V)	110
Frequency (Hz)	60
Power consumption (kWh/24h)	7,6
AMP (A)	2,8
Power (Watt)	495
Horse power (HP)	3/8
Alarm functions	
Alarm display as text - not codes	yes
Visual / acoustic alarm	yes / yes
Power failure alarm	yes
Adjustable high / low temperature alarm	yes / yes
Open door alarm	yes
Probe failure alarm	yes
Low battery alarm	yes
Compressor failure alarm	no
Battery backup for alarms (approx. hrs.)	72
Data logging & external connection	
Voltage free contact for remote alarm (e.g. GSM alarm module)	yes
Electronic data logger	yes
RS 485 port	yes
USB port for software update & data download	yes
Temperature chart recorder	optional
Display features	
Display type	4,3" with touch buttons
Number of optional reference probes	2
Password protection for turning unit on / off	yes
Temperature graph on display	yes
Other features	
Automatic defrost	no
Vacuum release port	no
Access port for external probe etc. (int. diameter mm)	no
Access port for external probe etc. (int. diameter inches)	no
Light	no
Lock with key	yes
Castors (total pcs) / castors with brake (pcs)	no
Fixed feet (pcs) / levelling feet (pcs)	0 / 4
Sub lids / inner doors (pcs)	1
Reversible door(s)	no
Total capacity of 50 mm / 2 inch boxes (pcs)	5
Total capacity of 75 mm / 3 inch boxes (pcs)	3
Total capacity of 96 mm / 3,8 inch boxes (pcs)	2
Refrigeration & cabinet	
Number of compressors	1
Refrigerant	EP88
Interior cabinet material	stainless steel
Exterior cabinet material	electrogalvanized steel
Colour (exterior cabinet)	white
Foam type	polyurethane
VIP vacuum insulated panels	no
Shipping	
Shipping weight (kg)	79
Shipping weight (lbs)	174
Shipping dimensions WxDxH (cm)	77x48x89
Shipping dimensions WxDxH (inches)	30,3x18,9x35
Shipping volume (m ³)	0,33
Shipping volume (cu. ft.)	11,65