



User Guide

Quality, Design and Innovation











home.liebherr.com/fridge-manuals



LIEBHERR

Contents

1	General safety instructions.....	3	7.2.19	Defrosting	34				
2	The appliance at a glance.....	4	7.2.20	Sensor calibration	36				
2.1	Included in delivery.....	4	7.2.21	Temperature alarm	36				
2.2	Overview of appliances and equipment.....	5	7.2.22	Door alarm	37				
2.3	Special features.....	5	7.2.23	Light alarm *.....	38				
2.4	Range of appliance use.....	5	7.2.24	Alarm simulation	39				
2.5	Sound emission of the appliance.....	6	7.2.25	Alarm forwarding	39				
2.6	Conformity.....	6	7.2.26	Demo mode	40				
3	Setting up and connecting.....	6	7.2.27	Resetting to factory settings	40				
3.1	Installation conditions.....	6	7.3	Messages.....	41				
3.2	Appliance dimensions.....	7	7.3.1	Warnings.....	41				
3.3	Transporting the appliance.....	7	7.3.2	Reminders.....	43				
3.4	Unpacking the appliance.....	7	8	Equipment.....	43				
3.5	Changing the door hinge.....	8	8.1	Safety lock.....	43				
3.6	Aligning the door.....	19	8.2	Sensors.....	44				
3.7	Installing the door handle.....	20	8.3	Interfaces.....	44				
3.8	Setting up the appliance.....	20	9	Maintenance.....	45				
3.9	Leveling out the appliance.....	20	9.1	Maintenance schedule.....	45				
3.10	Setting up multiple appliances.....	20	9.2	Defrosting the appliance.....	46				
3.11	Pushing the appliance under a countertop....	21	9.3	Cleaning the appliance.....	47				
3.12	After setup.....	21	10	Customer support.....	48				
3.13	Disposal of packaging.....	21	10.1	Technical data.....	48				
3.14	Connecting the appliance to the power supply.....	21	10.2	Technical malfunction.....	48				
4	Functionality of the Touch display.....	22	10.3	Customer Service.....	49				
4.1	Navigation and symbol explanation.....	22	10.4	Type plate.....	49				
4.2	Menus.....	23	11	Shutting down.....	49				
4.3	Sleep mode.....	23	12	Disposal.....	50				
5	Start-up.....	24	12.1	Preparing the appliance for disposal.....	50				
5.1	Switching on the appliance (first use).....	24	12.2	Disposing of the appliance in an environmentally friendly manner.....	50				
6	Storage.....	24	13	Additional information.....	50				
6.1	Information regarding storing items.....	24	14	Quick Start Guide for everyday use.....	51				
7	Use.....	24	<p>Congratulations on the purchase of your new appliance. With this purchase, you have chosen all the advantages of the latest refrigeration technology, guaranteeing you a high-quality appliance with a long life span and high operating safety.</p> <p>The equipment of your appliance gives you the highest level of day-to-day ease of operation.</p> <p>Together we are making an active contribution to the conservation of our environment by purchasing this appliance which is manufactured in an environmentally friendly process with the use of recyclable materials.</p> <p>We hope you enjoy your new appliance.</p> <p>The manufacturer is constantly working to improve all types and models. Therefore, please be aware that we reserve the right to make changes to the shape, equipment and technology.</p>						
7.1	Control and display elements.....	24	<table border="1"> <thead> <tr> <th>Symbol</th> <th>Explanation</th> </tr> </thead> <tbody> <tr> <td></td> <td>Read instructions Please read the information in these instructions carefully to understand all of the benefits of your new appliance.</td> </tr> </tbody> </table>			Symbol	Explanation		Read instructions Please read the information in these instructions carefully to understand all of the benefits of your new appliance.
Symbol	Explanation								
	Read instructions Please read the information in these instructions carefully to understand all of the benefits of your new appliance.								
7.1.1	Status display.....	25							
7.1.2	Display symbols.....	25							
7.1.3	Acoustic signals.....	25							
7.2	Appliance functions.....	26							
7.2.1	Notes on the appliance functions.....	26							
7.2.2	Switching appliance on and off	26							
7.2.3	Temperature	26							
7.2.4	Temperature recording	27							
7.2.5	Lighting *.....	27							
7.2.6	Settings menu access protection	28							
7.2.7	Access codes.....	29							
7.2.8	Maintenance interval reminder	30							
7.2.9	Language	30							
7.2.10	Temperature unit	30							
7.2.11	Display Brightness	31							
7.2.12	Alarm Sound.....	31							
7.2.13	Key Sound.....	31							
7.2.14	WiFi connection	32							
7.2.15	LAN connection	33							
7.2.16	Appliance information	34							
7.2.17	Operating hours	34							
7.2.18	Software	34							

Symbol	Explanation
	Additional information online The digital manual with supplemental information can be found online by scanning the QR code on the front page of this manual or by entering the service number at home.liebherr.com/fridge-manuals .
	Check appliance Check all parts for transport damage. If you have any complaints, please contact your agent or customer service.
	Differences These instructions apply to a range of models, so there may be differences. Sections that apply to certain models only are indicated by an asterisk (*).
	Instructions and results Instructions are marked with a ▶. Results are marked with a ▷.
	Videos Videos about the appliances are available on the YouTube channel of Liebherr-Hausgeräte.

Open-source licenses:

The appliance includes software components that make use of open-source licenses. You can find information on the open-source licenses to be used here: home.liebherr.com/open-source-licenses

These operating instructions apply to:

- SRTvg 1501
- SRTvg 1511

1 General safety instructions

Please keep these operating instructions in a safe place so you can refer back to them at any time.

If you pass the appliance on, please hand these operating instructions to the new owner.

Read and follow these instructions. They contain safety information which is important for safe and problem-free installation and operation. Always read and follow the safety information.

Dangers for the user:

- This appliance may only be used by specialist and laboratory personnel who have been trained for this purpose and are familiar with all the safety measures for work in a laboratory. Children and persons with impaired physical, sensory or mental abilities or with a lack of experience and knowledge may not commission or operate this appliance.
- **IMPORTANT:** The power plug must be easily accessible so that the appliance can be disconnected

from the mains quickly in an emergency. It must not be behind the back of the appliance.

- Always hold the plug of the cable when disconnecting the appliance from the power supply. Do not pull on the cable.
- Remove the plug or disconnect via the fuse if there is a malfunction.
- **WARNING:** Do not damage the power cable. Do not operate the appliance with a faulty power cable. If the supply cord is damaged, it must be replaced by the manufacturer, its service agent or similarly qualified persons in order to avoid a hazard. For Plug and Play connection cables, the exchange may be carried out by the customer.
- **WARNING:** Multi-sockets/power distributors and other electronic appliances (such as halogen transformers) may not be placed and operated behind appliances.
- **WARNING:** Do not block the ventilation openings in the appliance housing or in the installation housing.
- Repairs and work on the appliance may only be carried out by Customer Service or other specifically trained qualified personnel.
- Always follow the instructions when assembling, connecting and disposing of the appliance.

Risk of fire:

- The refrigerant contained within the appliance (specifications on the type plate) is environmentally friendly, but flammable. Leaking refrigerant can ignite.
 - **WARNING:** Do not damage the refrigerant circuit.
 - Do not handle ignition sources inside the appliance.
 - **WARNING:** Do not use electrical appliances inside the food storage compartments of the appliance, unless they are of the type recommended by the manufacturer.
 - If refrigerant leaks: Remove naked flames or ignition sources located near the area of the leak. Ventilate the room well. Contact Customer Service.
- Do not operate the appliance near explosive gases.
- Do not store or use gasoline or other flammable gases and liquids near the appliance.
- Do not store explosive substances such as aerosol cans with a flammable propellant in this appliance. You can recognize such spray cans by the printed list of contents or by a flame symbol. Any leaking gases can be ignited by electrical components.
- Keep lit candles, lamps and other objects with naked flames away from the appliance so they do not cause a fire.
- Alcoholic liquids or other containers holding alcohol must always be tightly sealed for storage purposes. Any leaking alcohol can be ignited by electrical components.

Risk of falling or toppling over:

- Do not stand on the base, drawers, doors etc. or use them as improper supports.

The appliance at a glance

Danger of frostbite, feeling of numbness and pain:

- Avoid prolonged skin contact with cold surfaces or chilled/frozen food or take protective measures, e.g. wear gloves.

Risk of injury and damage:

- **WARNING:** Do not use mechanical devices or other means to accelerate the defrosting process, other than those recommended by the manufacturer.
- **WARNING:** Risk of injury due to electric shock! There are live electrical parts under the cover. Have the LED interior lighting replaced or repaired only by Customer Service or other suitably trained professionals.*
- **NOTICE:** The appliance must only be operated using original manufacturer accessories or accessories from other providers approved by the manufacturer. The user bears the risk of using accessories which are not approved.

Risk of crushing:

- Do not reach into the hinge when opening and closing the door. Fingers may get trapped.

California Proposition 65:

- **WARNING:** This product can expose you to chemicals including Diisononyl Phthalate (DINP), which is known to the State of California to cause cancer, and Diisodecyl Phthalate (DIDP), which is known to the State of California to cause birth defects or other reproductive harm. For more information, go to www.P65Warnings.ca.gov

Specialist personnel qualifications:

The appliance may only be installed, tested, maintained, and commissioned by specialist personnel who are familiar with the installation, commissioning, and operation of the appliance. Specialist personnel are persons who, on account of their specialist training, knowledge and experience as well as their knowledge of the relevant standards, are able to assess and perform the work assigned to them and identify potential hazards. They must have training, instruction, and authorization to work on the appliance.

Symbols on the device:



The symbol may be located on the compressor. It refers to the oil in the compressor and refers to the following danger: **Can be fatal if swallowed or inhaled.** This notice only applies for recycling. There is no danger during normal operation.



WARNING: Risk of fire / flammable materials. The symbol is located on the compressor and indicates the danger from flammable materials. Do not remove the label.

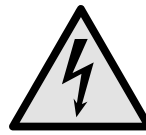

The symbol is located on the back of the appliance near the alarm relay and indicates the following danger: **Electric shock!** Even if an appliance is disconnected from the mains there may still be extraneous voltage. Do not remove the label.



This label or a similar one may be located on the rear of the appliance. This label indicates that there are vacuum insulation panels (VIP) or perlite panels in the door and/or housing. This notice only applies for recycling. Do not remove the label.

Observe the warning messages and other detailed information in the other sections:

	DANGER	Indicates an immediately hazardous situation, which if not avoided, will result in death or serious injury.
	WARNING	Indicates a hazardous situation, which if not avoided, could result in death or serious injury.
	CAUTION	Indicates a hazardous situation, which if not avoided, could result in minor or moderate injury.
	NOTICE	Indicates a hazardous situation, which if not avoided, could result in damage to property.
	Note	Indicates useful advice and tips.

2 The appliance at a glance

2.1 Included in delivery

Check all parts for transport damage. If you have any issues, please contact your dealer or Customer Service. (see 10.3 Customer Service)

The delivery contains the following parts:

- Freestanding appliance
- Equipment *
- Installation materials *
- Operating instructions
- Warranty documents
- Quality certificate *
- Power cable

2.2 Overview of appliances and equipment

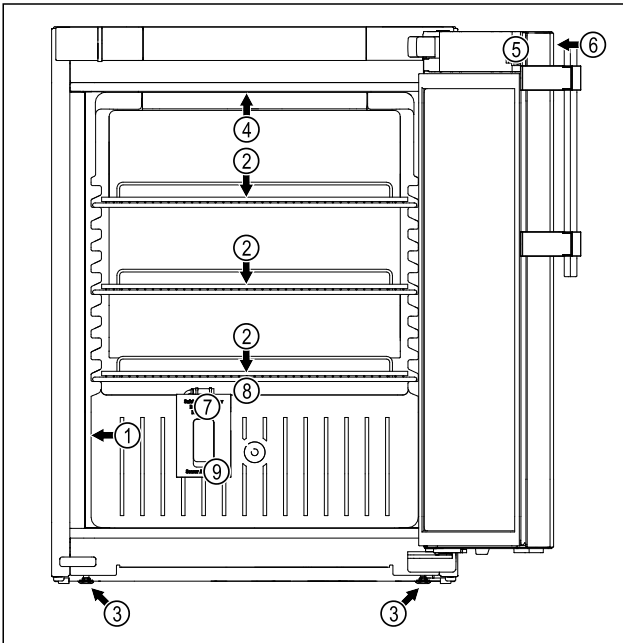

Fig. 1 Example illustration

Equipment

- | | |
|------------------------|--|
| (1) Type plate | (6) Operating elements and temperature display |
| (2) Support rack | (7) Safety thermostat sensor |
| (3) Adjustable foot | (8) Defrost water drain |
| (4) Interior lighting* | (9) Sensor feedthrough |
| (5) Lock | |

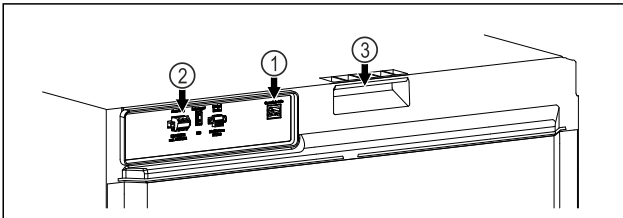

Fig. 2 Exemplary illustration of the rear side

Equipment

- | | |
|---------------------------------|------------------|
| (1) LAN/WLAN interface * | (3) Carrying aid |
| (2) Potential-free alarm output | |

2.3 Special features

Note

Accessories are available from the Liebherr Service Center. The address for your respective country can be found on the back of the instructions.

SmartModule

You can fit the appliance with a SmartModule.

This is a WLAN and LAN interface for the connection between the appliance and an external documentation and alarm system, such as the Liebherr SmartMonitoring dashboard, for example.

The Liebherr SmartMonitoring dashboard is not available in all countries. Check for availability via the QR code (see 7.2.14 WiFi connection) and entering your model.

Retrofitting drawers

Temperature qualification is required when retrofitting drawer systems in Liebherr refrigerators/freezers where these are used for temperature-sensitive materials such as chilled drugs and refrigerated products that are subject to specific standard requirements. Retrofitting drawers in Liebherr refrigerators/freezers can result in the goods stored becoming spoiled or damaged. The retrofitting must therefore be completed exclusively by authorized service providers from the manufacturer of the refrigerator/freezer.

2.4 Range of appliance use

Intended use

This laboratory refrigerator is suitable for professional storage of products at temperatures between 3 °C (38 °F) and 16 °C (60 °F).

Typical products to be stored include research samples, reagents, laboratory inventory etc.

Storage of temperature-sensitive substances requires the use of an independent, permanently monitored alarm system. This alarm system must be designed such that a responsible person can record every alarm condition to be able to take suitable measures.

Foreseeable incorrect use

Do not use the appliance for the following applications:

- Storage and cooling of:
 - Chemically unstable, flammable or corrosive substances
 - Blood, plasma or other body fluids for the purpose of infusion, application or introduction in the human body.
- Use in potentially explosive atmospheres.
- Use outdoors or in areas exposed to dampness and splashing water.

Any misuse of the appliance may result in damage to or spoilage of stored goods.

Climate classes

The climate class for your appliance is printed on the identification plate.

Setting up and connecting

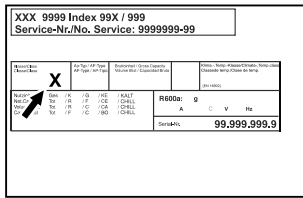

Fig. 3 Type plate

(X) This climate class indicates the environmental conditions in which the appliance can be operated safely.

Climate class (X)	max. room temperature	max. humidity	rel.
7	35 °C (95 °F)	75%	

Note

The minimum permitted room temperature at the setup location is 10 °C (50 °F).

The interior temperature of the appliance never exceeds the ambient temperature at the setup location.

Slight condensation may form on the glass door on the side walls if the boundary conditions are exceeded.

2.5 Sound emission of the appliance

The A-weighted emission sound pressure level during operation of the appliance is below 70 dB(A) (sound power rel.1 pW).

2.6 Conformity

The refrigerant circuit has been tested for leaks. The appliance complies with the relevant safety regulations as well as the corresponding directives.

3 Setting up and connecting

3.1 Installation conditions

The installation conditions are crucial to ensure that you can operate your appliance safely, efficiently, and trouble-free.

- Observe all safety instructions.
- Observe the installation location and position in the room.



WARNING

Danger of fire due to incorrect positioning!

If the power supply cable or plug touches the back of the appliance, the vibration can damage the power supply cable or the plug resulting in a short circuit.

- ▶ Make sure the power supply cable is not trapped under the appliance when you position the appliance.
- ▶ Install the appliance so that it does not touch any plugs or power cables.
- ▶ Do not connect any appliances to sockets in the area of the back of the appliance.
- ▶ Do **not** place and operate power strips/power distributors and other electronic devices (such as halogen transformers) at the back of the appliances.



WARNING

Risk of fire due to moisture!

If live parts or the power cord get wet, this can cause a short circuit.

- ▶ The appliance is designed for use in enclosed spaces. Do not operate the appliance in open space or in damp areas or where there is spray.



WARNING

Leaking refrigerant and oil!

Fire. The refrigerant contained within the appliance is environmentally friendly, but flammable. The oil contained within the appliance is flammable. Escaping refrigerant and oil can ignite if they are of high enough concentration and are exposed to an external heat source.

- ▶ Do not damage the pipelines of the coolant circuit and the compressor.

3.1.1 Installation location

- The optimum installation location is a dry and well-ventilated space.
- If the appliance is set up in a very humid environment, condensation may form on the outside of it. Always ensure good ventilation at the installation location.
- The more refrigerant there is in the appliance, the larger the room in which the appliance is installed must be. If the room is too small, a flammable gas/air mixture may form in the event of a leak. Per 8 g (0.28 oz) refrigerant, the installation space must be at least 1 m³ (35.5 ft³) in size. Information on the refrigerant contained can be found on the type plate inside the appliance.
- The floor at the installation location must be horizontal and level.

- The installation location must be able to support the weight of the appliance, including its maximum storage capacity. (see 10.1 Technical data)
- Do not install an appliance on top of another one, a countertop, a cabinet or similar.

C	605 mm (23 13/16 in)
D	1162 mm (45 3/4 in)

3.1.2 Position in the space

- Do not set up the appliance in an area with direct sunlight, next to a heating unit or similar.
- Always place the rear of the appliance directly against the wall.
- If you set up the appliance on a raised surface, you must install the anti-tip bracket.
If you place the appliance on top of another one, you must install the connecting frame with anti-tip bracket (included in the connecting frame).
If you place the appliance on a base with casters, you must install the base with the anti-tip bracket (included in the plinth with casters).
- If you set up the appliance on a base with feet, you must mount the base with the anti-tip bracket (included in the base with feet).
The anti-tip bracket can be purchased from the Liebherr-Hausgeräte store at home.liebherr.com/shop/de/deu/zubehor.html.
- Use in potentially explosive atmospheres is not permitted.

3.2 Appliance dimensions

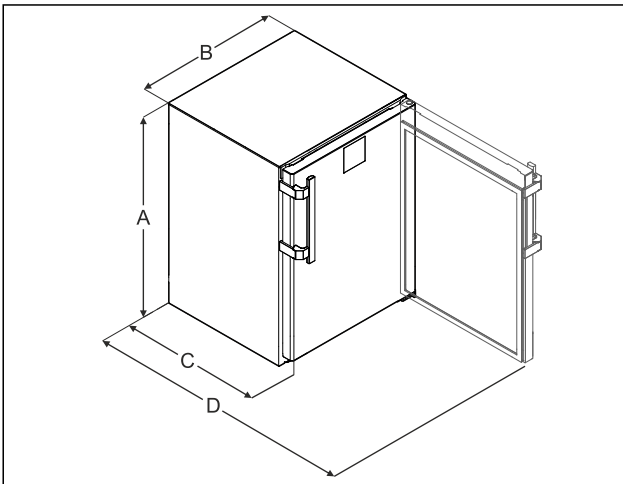

Fig. 4 Example illustration

- (A)** Appliance height including feet/rollers
- (B)** Appliance width without handle [handle depth = 45 mm (1 6/8 in)]
- (C)** Appliance depth without handle [handle depth = 45 mm (1 6/8 in)]
- (D)** Appliance depth with open door

A	819 mm (32 1/4 in)
B	597 mm (23 1/2 in)

3.3 Transporting the appliance



WARNING

There is a risk of injury from pieces of broken glass.* When transporting at an altitude of more than 1500 m (4,921.26 ft), the glass panes of the door may break. This can result in sharp-edged fragments, which can cause serious injuries.

- ▶ Adopt suitable protective measures.

3.3.1 Transporting the appliance for initial installation

Make sure that the following requirements are fulfilled:

- Appliance is packaged.
- The appliance is upright.
- ▶ Have two people transport the appliance.
- ▶ Unpack the appliance.

3.3.2 Transporting the appliance after initial installation

Observe the following instructions if you want to transport or move the appliance after initial installation.

Make sure that the following requirements are fulfilled:

- Appliance is empty.
- The appliance is upright.
- Appliance with door(s): The door is secured against undesired opening.
- Appliance with pull-out cart: The pull-out cart is secured against undesired opening.
- Appliance with adjustable feet: Adjustable feet are turned in.
- ▶ Have two people transport the appliance.

After transporting it:

- ▶ Turn out the adjustable feet on the appliance.
- ▶ Align the appliance.

3.4 Unpacking the appliance

- ▶ Check the appliance and the packaging for transport damage. Contact the supplier immediately if you suspect any damage. Do not connect the appliance to the power supply.
- ▶ Remove all packaging materials from the rear or the side walls of the fridge that may prevent proper installation or prevent air flow and ventilation.

Setting up and connecting

3.5 Changing the door hinge

3.5.1 Safety instructions



WARNING

Risk of injury if the door is not reversed correctly!

- ▶ Have a specialist change the door hinge.



WARNING

Risk of injury and material damage from the door weight!

- ▶ Only replace the door hinge if you are able to carry a weight of 15 kg (33.07 lb).
- ▶ Have two people replace the door hinge.

NOTICE

Live parts!

Damage to electrical components.

- ▶ Pull the power plug before changing the door hinges.

3.5.2 Tool



3.5.3 Removing the worktop*

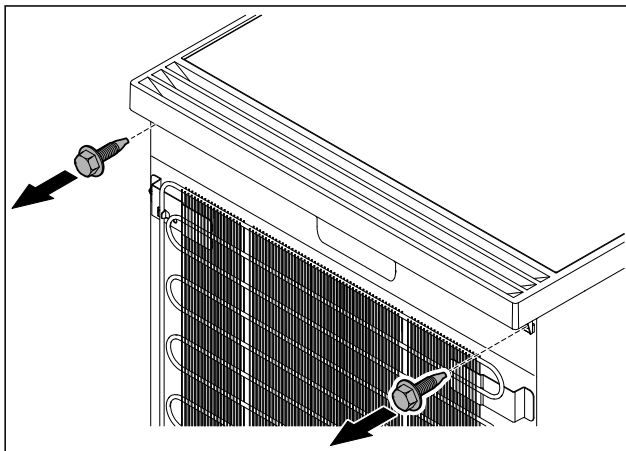

Fig. 5

- ▶ Loosen the screws.

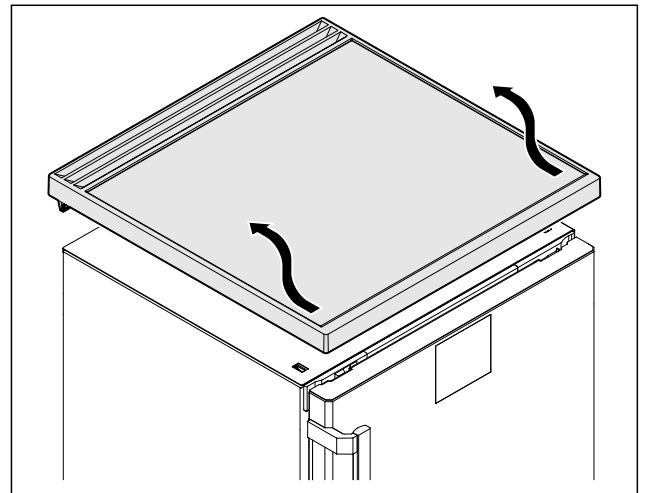

Fig. 6

- ▶ Remove the worktop.

3.5.4 Taking off the covers

- ▶ Open the door.

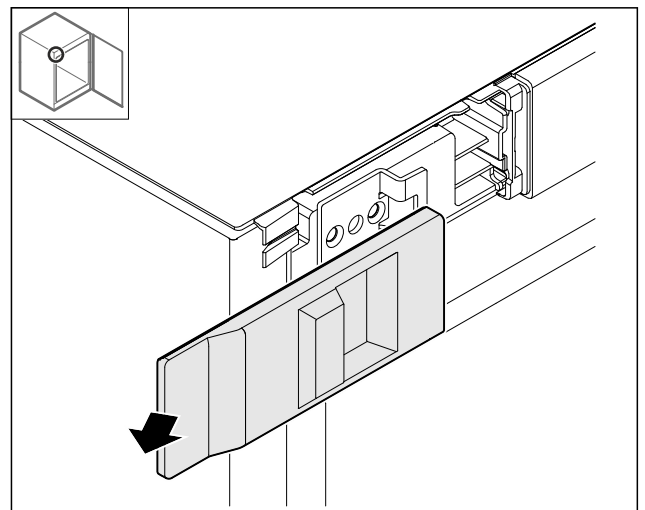

Fig. 7

- ▶ Remove the cover.

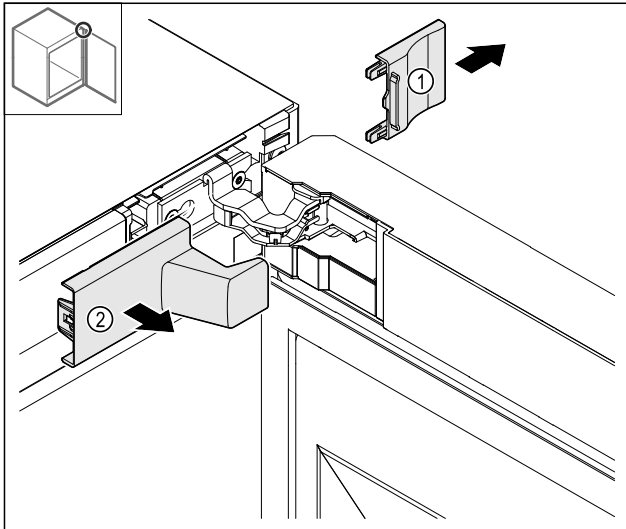

Fig. 8

- Lift off the cover Fig. 8 (1) and then remove Fig. 8 (2).

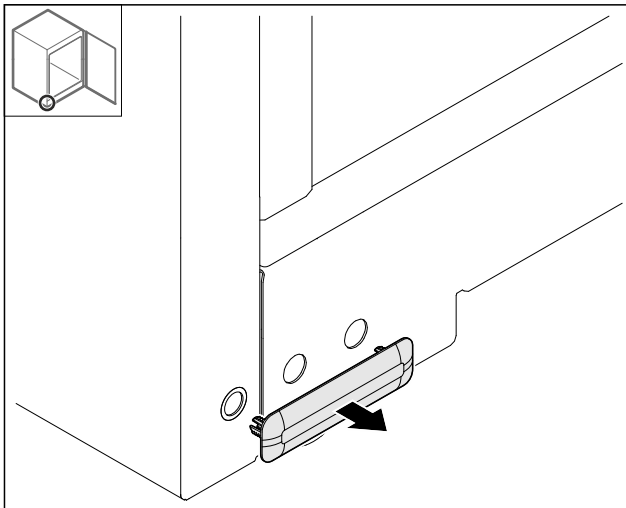

Fig. 9

- Remove the cover.

3.5.5 Taking off the faceplate

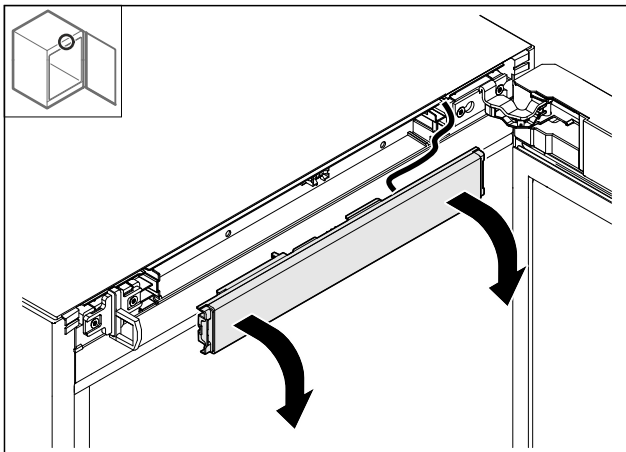

Fig. 10

- Take off the faceplate.

- **Tip for the next steps:** Take a picture of the cable installation.

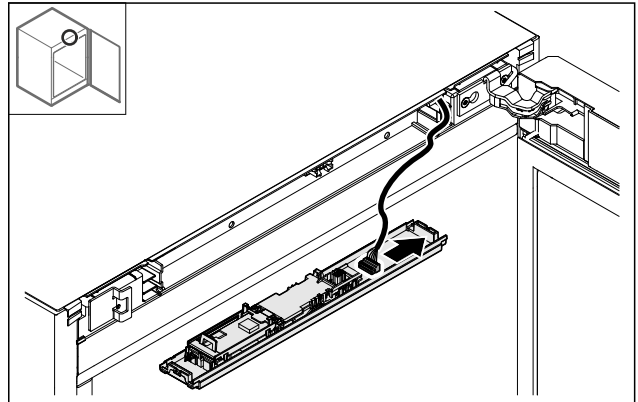

Fig. 11

- Pull out the plug.

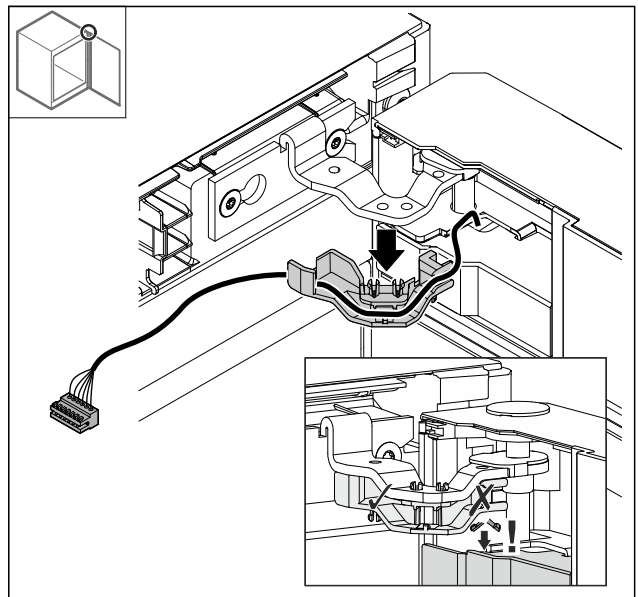

Fig. 12

- Pull out the cable with bracket from the hinge **carefully** to prevent the latching tabs from breaking.
- The cable with the bracket is hanging on the door.

3.5.6 Taking off the door

NOTICE

Risk of injury if the door tips out!

- Hold the door.

Setting up and connecting

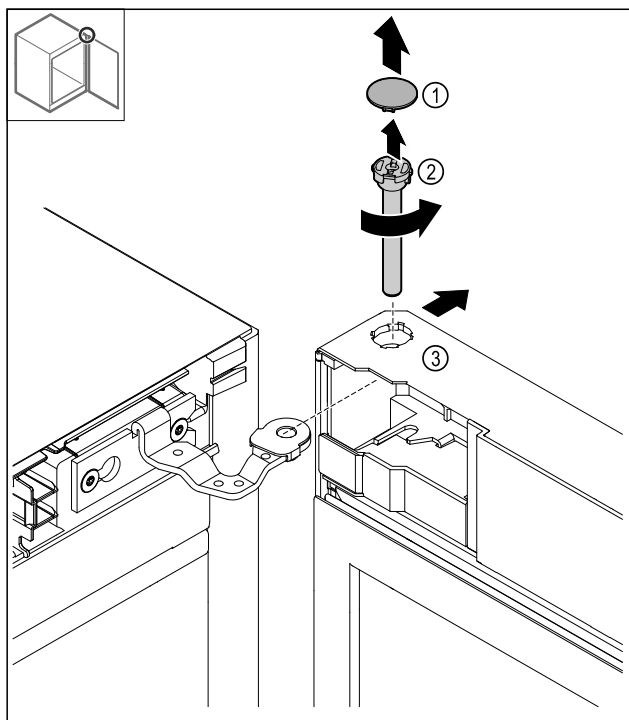

Fig. 13

- ▶ Take off the Fig. 13 (1) cover.
- ▶ Unscrew the pin Fig. 13 (2) counterclockwise and pull it out.
- ▶ Tilt the door Fig. 13 (3) slightly.

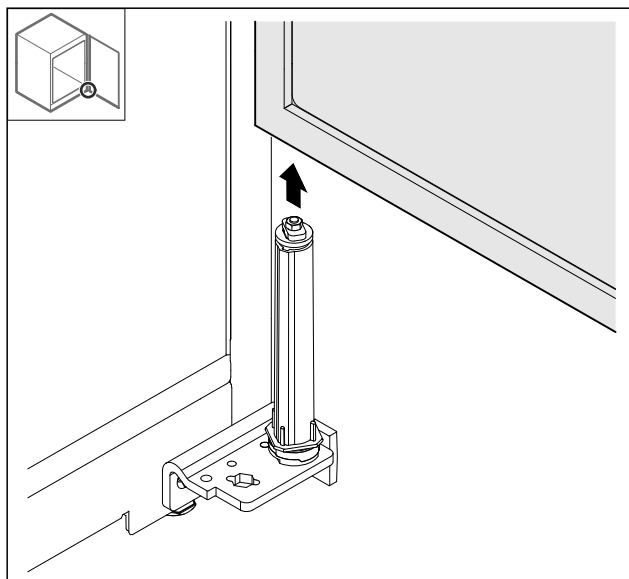

Fig. 14

- ▶ Pull out the door from the top.
- ▶ Place the door on a soft support.

3.5.7 Moving the cover at the top

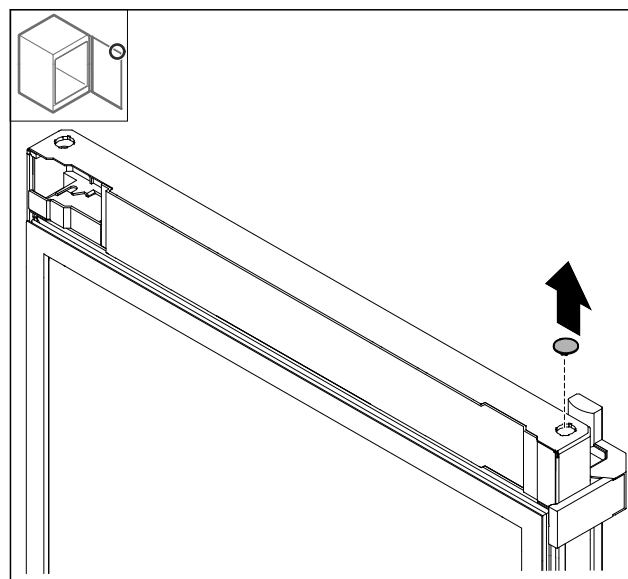

Fig. 15

- ▶ Pull out the cover.

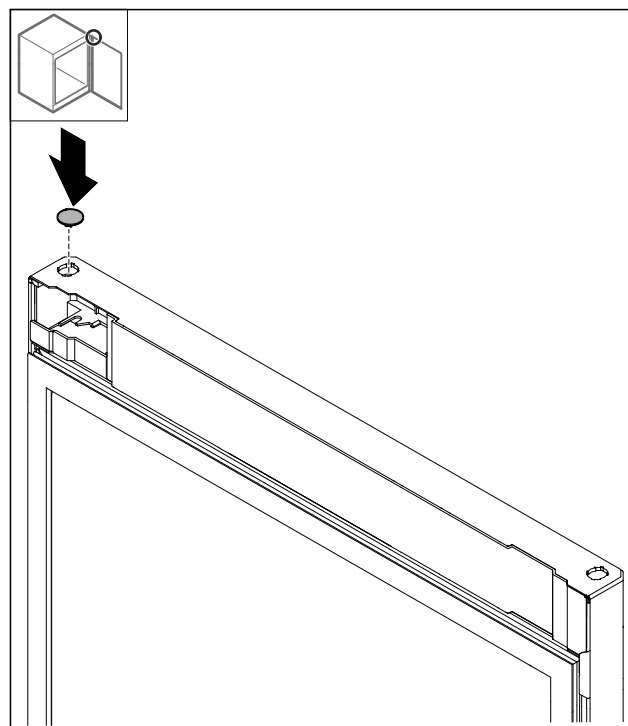

Fig. 16

- ▶ Insert the cover.

3.5.8 Moving the stop plate

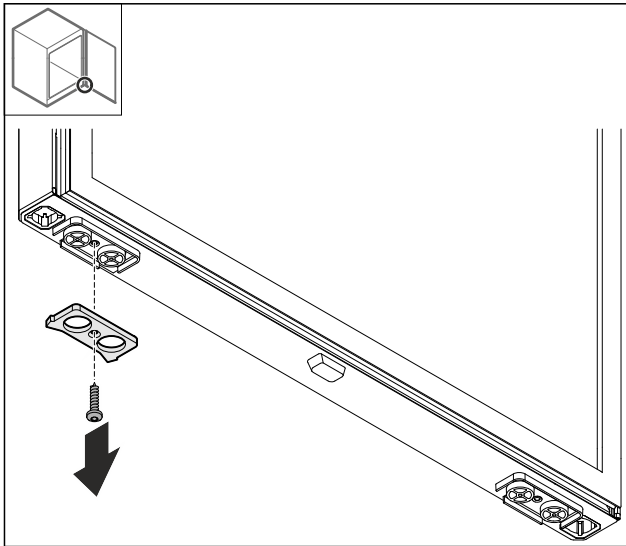

Fig. 17

- Remove the stop plate.

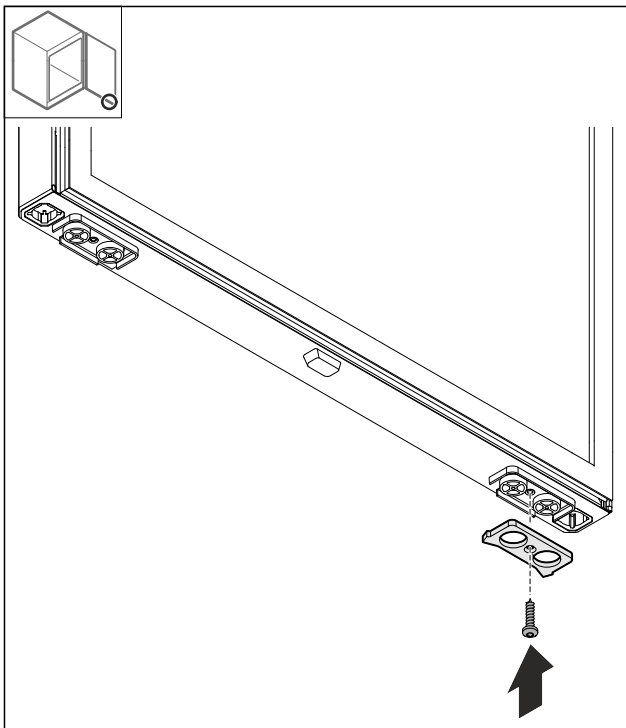

Fig. 18

- Install the stop plate on the opposite side.

3.5.9 Repositioning the handle

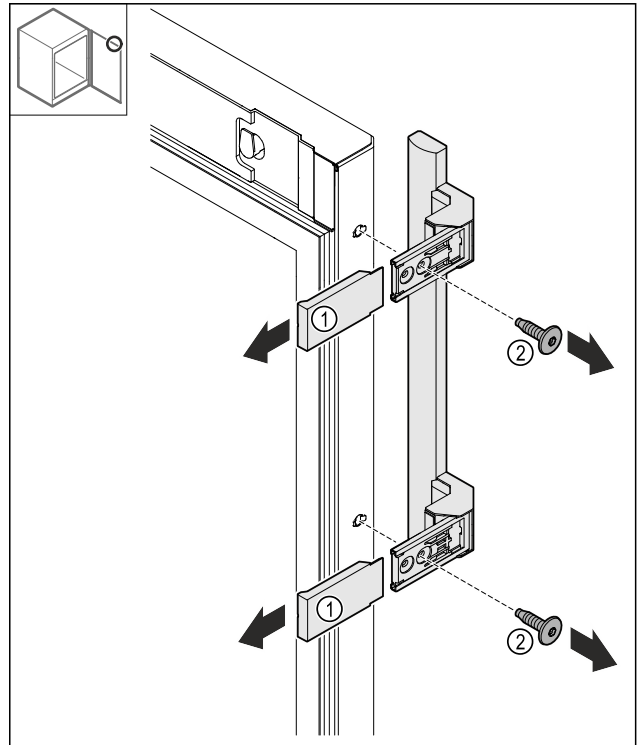

Fig. 19

- Pull off the Fig. 19 (1) covers.
- Loosen the Fig. 19 (2) screws.
- Take off the handle.

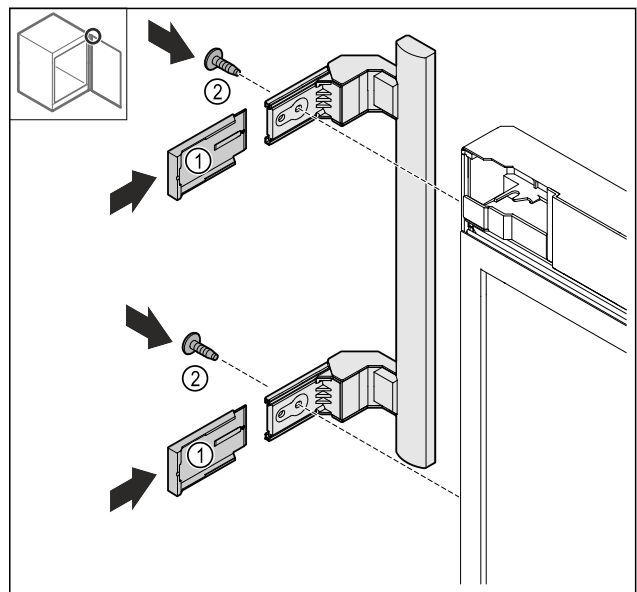

Fig. 20

- Move the plug to the opposite side.*
- Screw on the handle on the opposite side.
- Slide on the Fig. 20 (1) covers.

3.5.10 Taking off the cover

- Lock the door.

Setting up and connecting

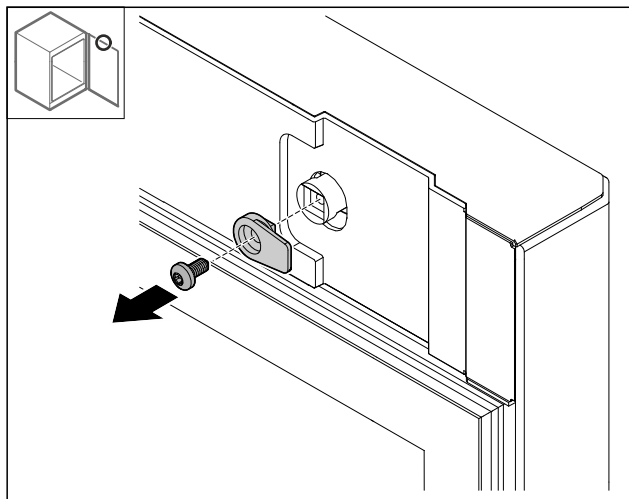

Fig. 21

- ▶ Remove the closing hook.

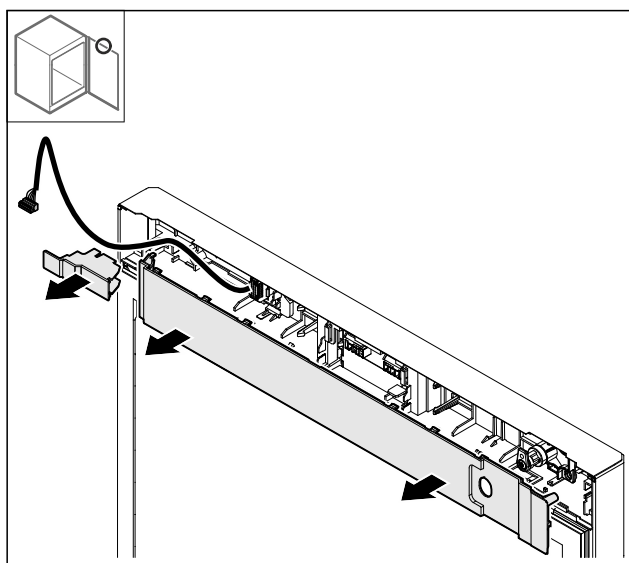

Fig. 22

- ▶ Take off the covers.

3.5.11 Repositioning the plug holder*

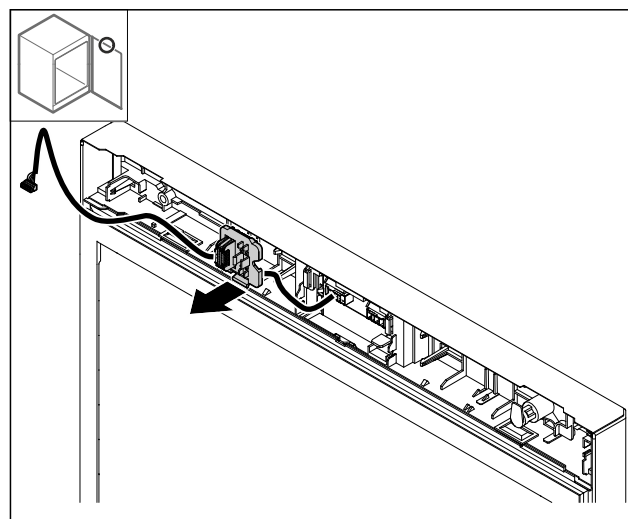

Fig. 23 You can turn the installation position of the plug holder by 180°.

- ▶ Unlatch the plug holder.

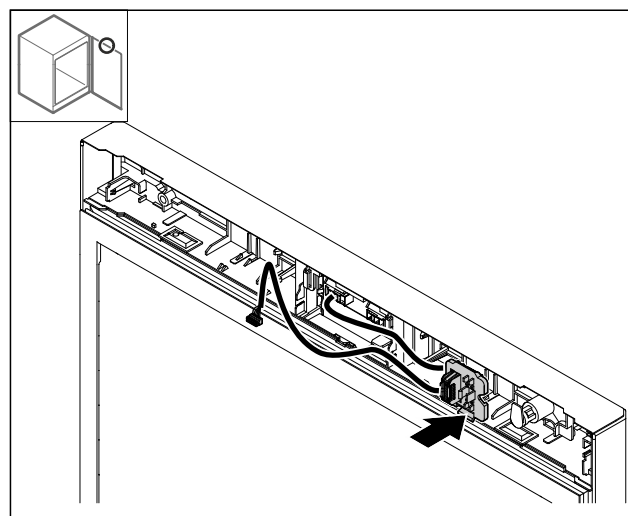

Fig. 24

- ▶ Latch the plug holder on the opposite side.

3.5.12 Repositioning the cable*

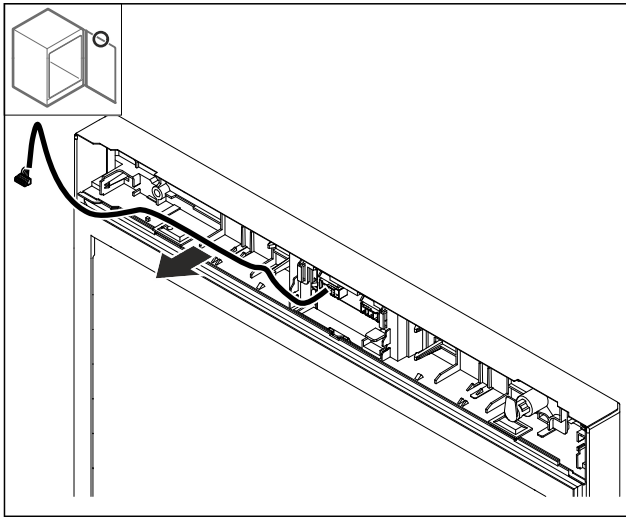

Fig. 25

► Pull out the cable.

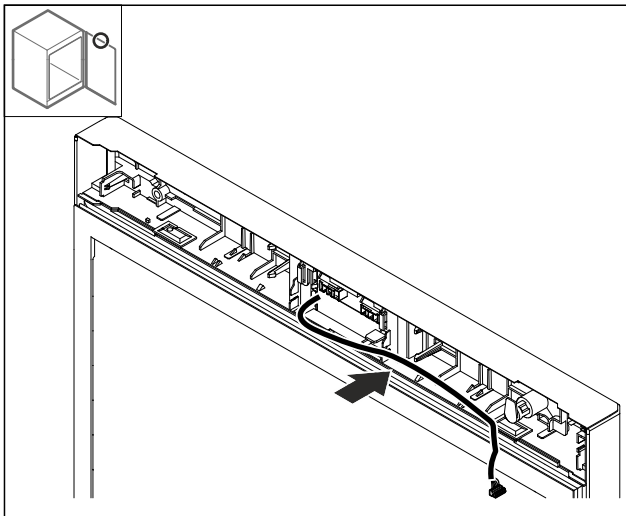

Fig. 26

► Route the cable on the opposite side.

3.5.13 Repositioning the lock

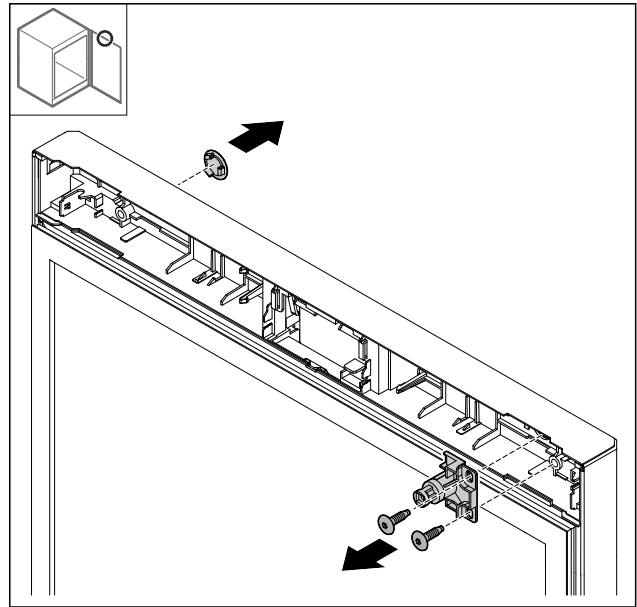

Fig. 27 Example illustration: Foamed door

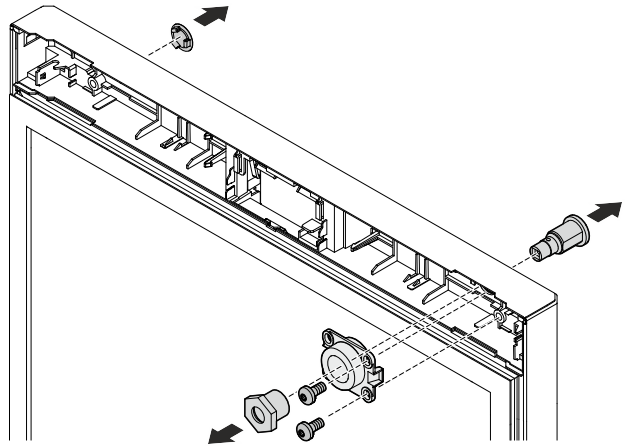

Fig. 28 Example illustration: Glass door

► Take off the cover.
► Remove the lock.

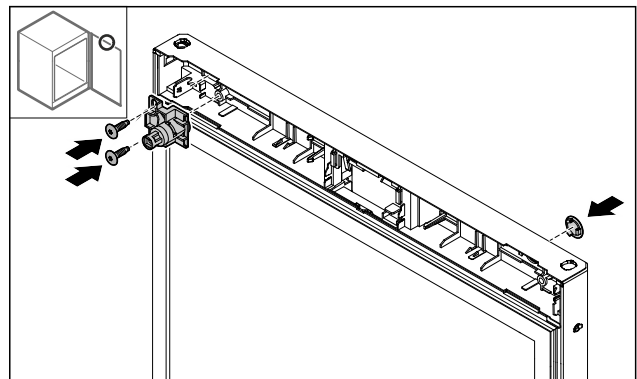

Fig. 29 Example illustration: Foamed door

Setting up and connecting

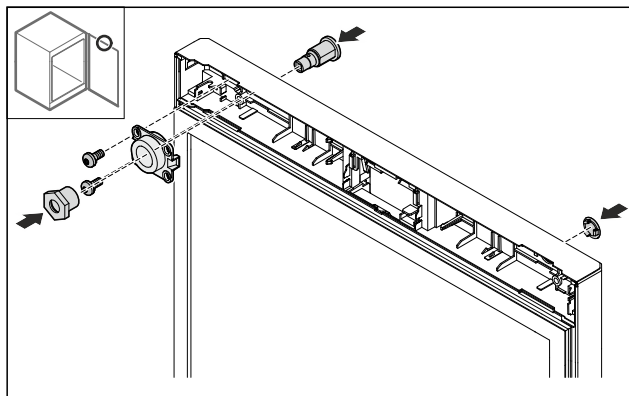

Fig. 30 Example illustration: Glass door

- ▶ Install the cover on the opposite side.
 - ▶ Foamed door: Install the lock turned 180° on the opposite side.
- or-
- ▶ Glass door: Install the lock and bracket on the opposite side.

3.5.14 Putting on the cover

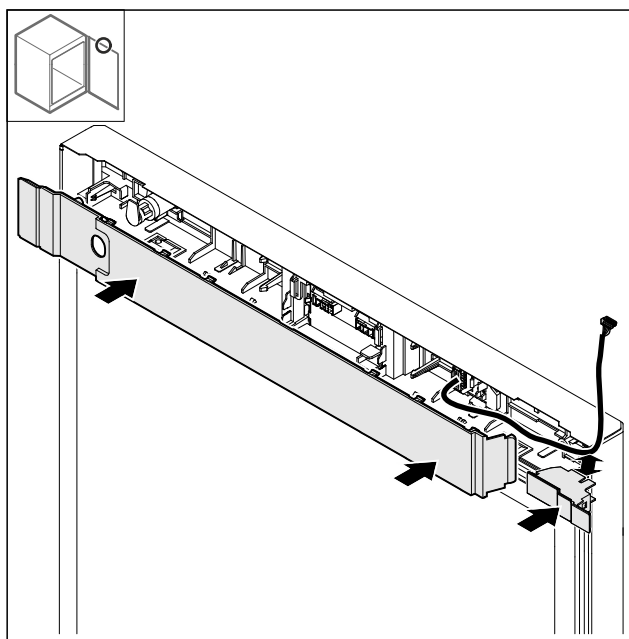

Fig. 31

- ▶ Install the covers turned 180°. Make sure that the cable is guided through the top opening of the small cover.

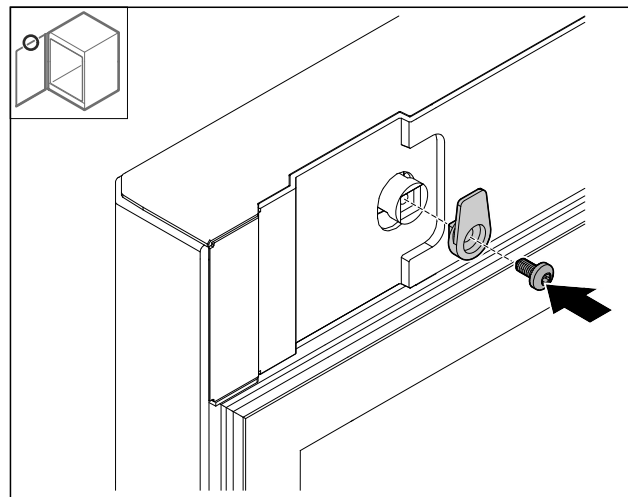

Fig. 32

- ▶ Installing the closing hook.

3.5.15 Repositioning the top hinge

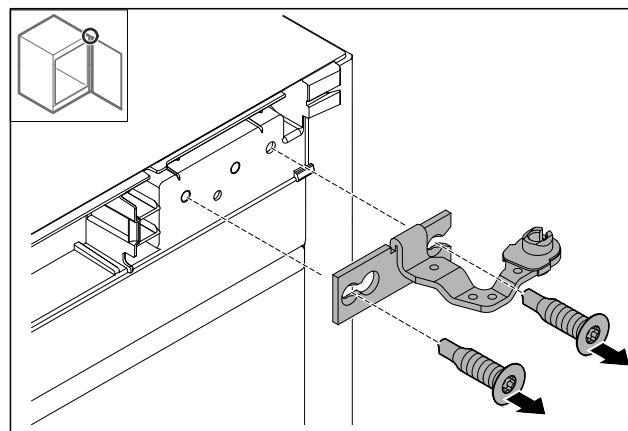

Fig. 33

- ▶ Pull off the hinge.

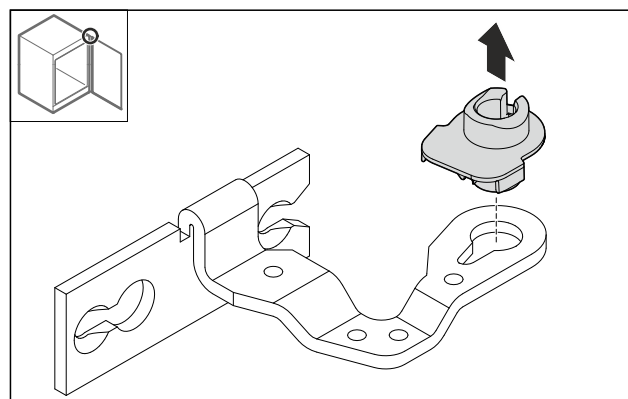

Fig. 34

- ▶ Press out the bearing bush.

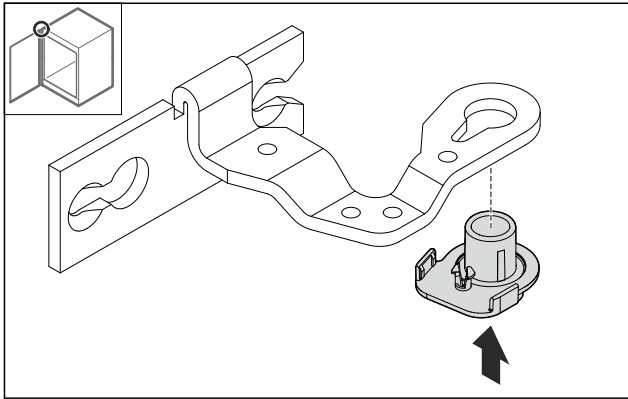

Fig. 35

- ▶ Press the bearing bush into the bottom turned 180°.

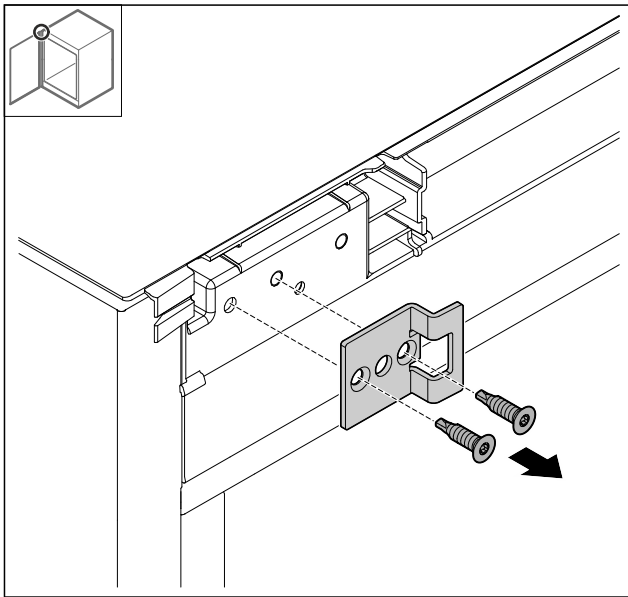

Fig. 36

- ▶ Pull off the locking bracket.

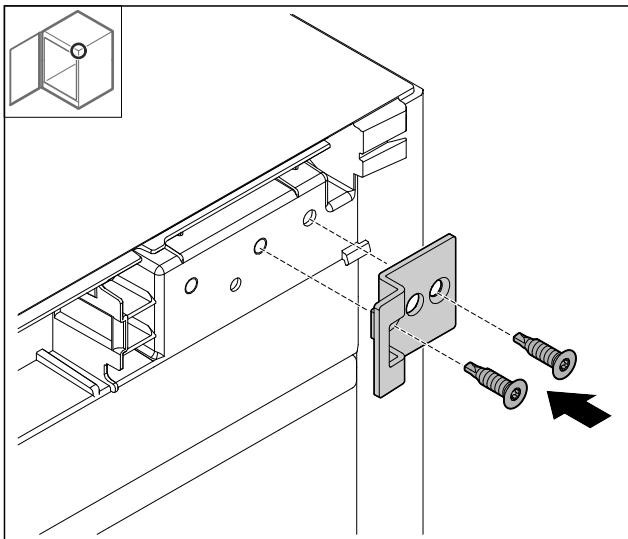

Fig. 37

- ▶ Mount the locking bracket turned 180° on the opposite side.

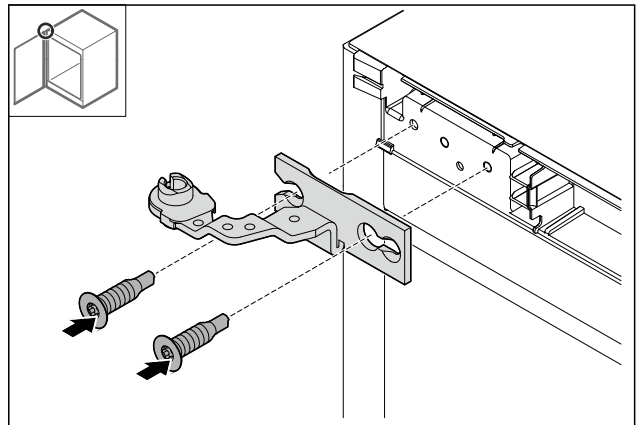

Fig. 38

- ▶ Install the hinge.

3.5.16 Repositioning the bottom hinge

NOTICE

Danger of injury due to tensioned spring!

- ▶ Do not disassemble the screw connection Fig. 39 (1) of the closing system.

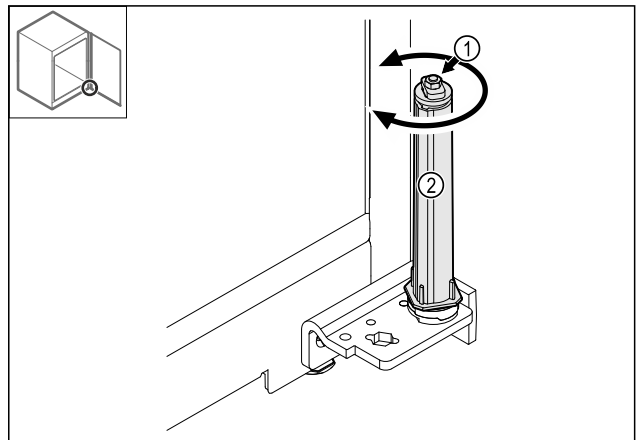

Fig. 39

- ▶ Turn the closing system Fig. 39 (2) until it clicks.
- ▶ The closing system pretension is released.

Setting up and connecting

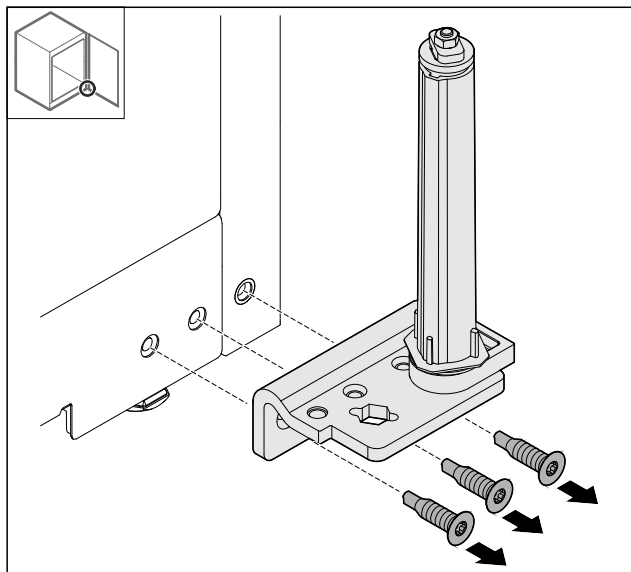

Fig. 40

► Pull off the hinge angle.

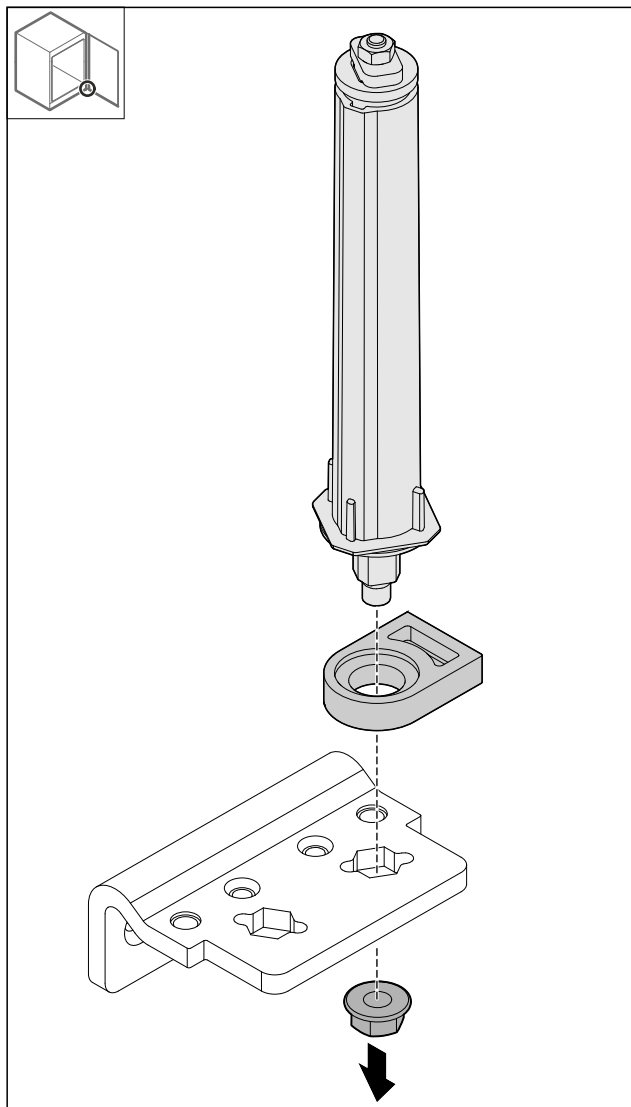

Fig. 41

► Loosen the nuts.

Note

When inserting, make sure that the closing system is aligned correctly.

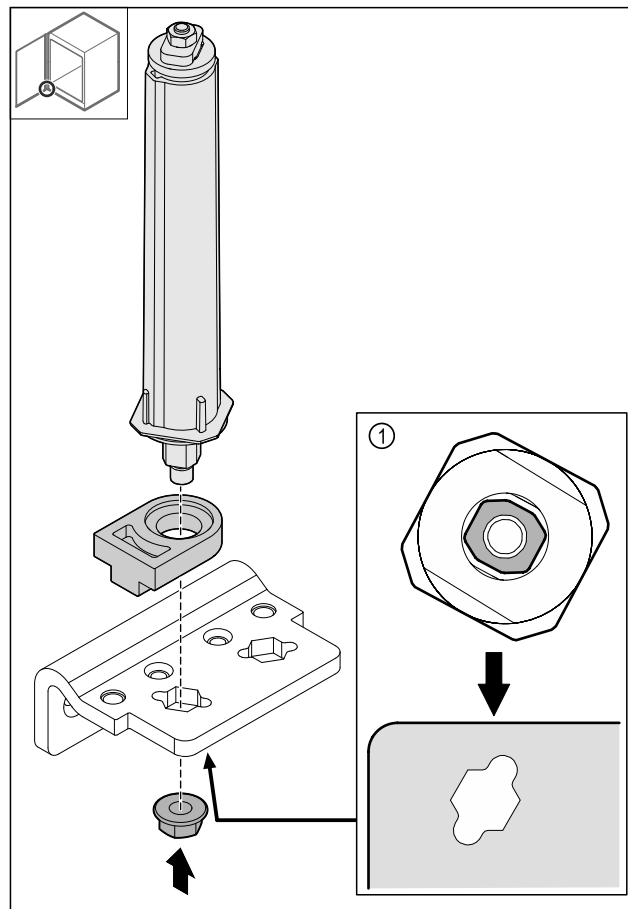

Fig. 42 View from below: Fig. 42 (1)

► Reposition the closing system in the hinge angle and fasten it with the nut.

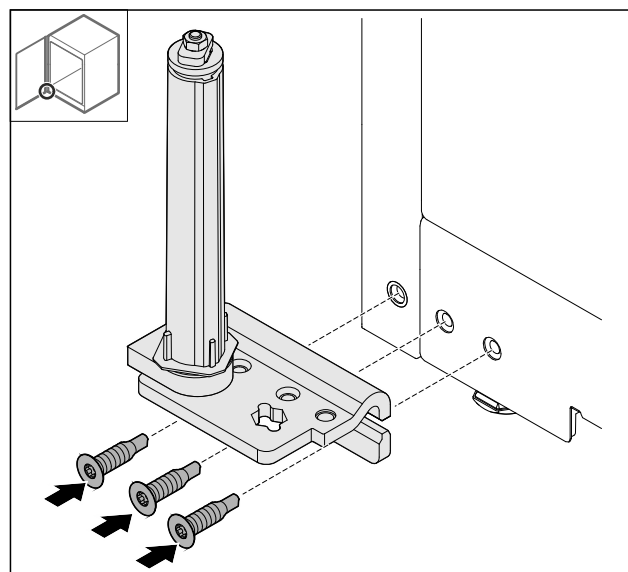

Fig. 43

- ▶ Install the hinge angle on the opposite side.

Note

The correct alignment and tension is important for the functioning of the closing system.

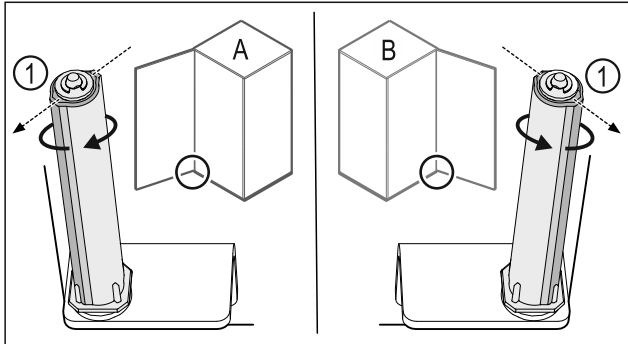

Fig. 44 Left stop (A) / right stop (B)

- ▶ Turn the closing system against the resistance until the bridge of the closing system Fig. 44 (1) shows outward.
- ▶ The closing system remains in this position on its own.
- ▶ The closing system is aligned and pre-tensioned.

3.5.17 Installing the door

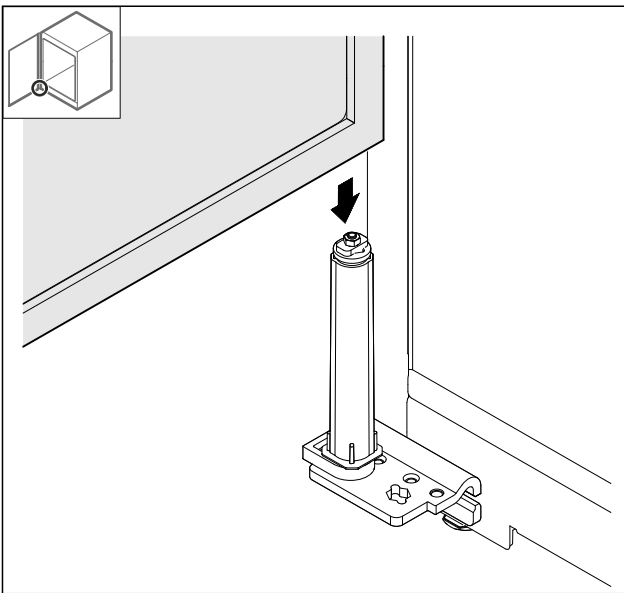

Fig. 45

- ▶ Set the door onto the closing system.

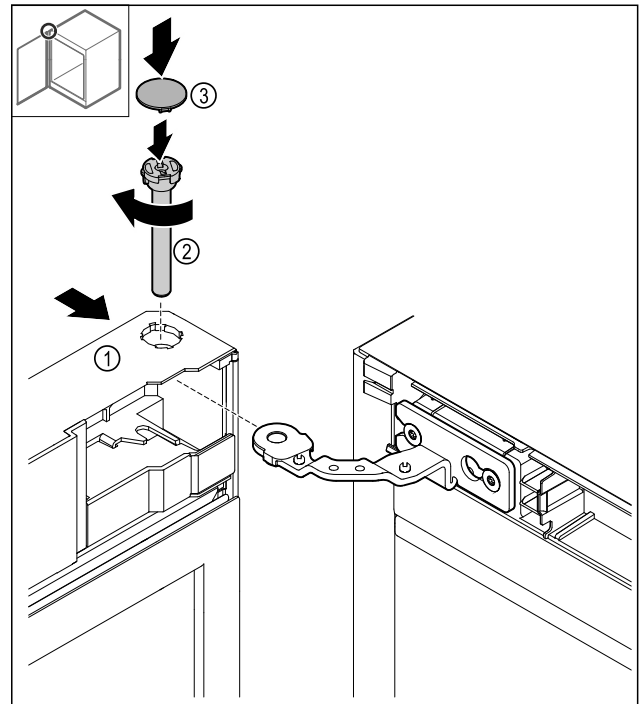

Fig. 46

- ▶ Push the door Fig. 46 (1) up onto the hinge.
- ▶ Insert the pin Fig. 46 (2) firmly screw it in clockwise.
- ▶ Put on the Fig. 46 (4) cover.

3.5.18 Pressing on the faceplate

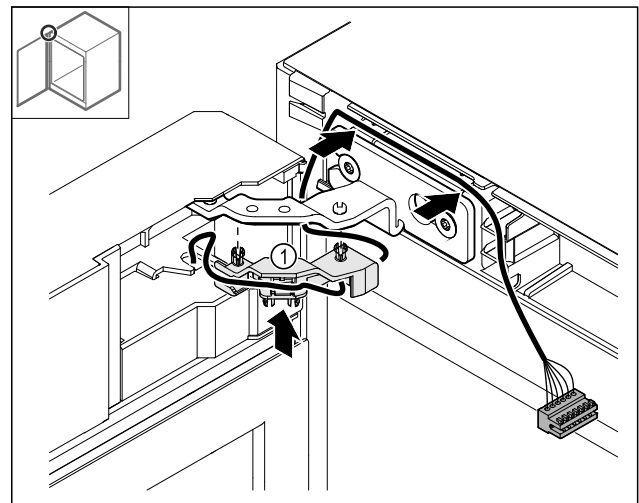

Fig. 47

- ▶ Press the cable bracket Fig. 47 (1) into the hinge.
- ▶ Install the cable in the hinge in the direction of the faceplate.

Setting up and connecting

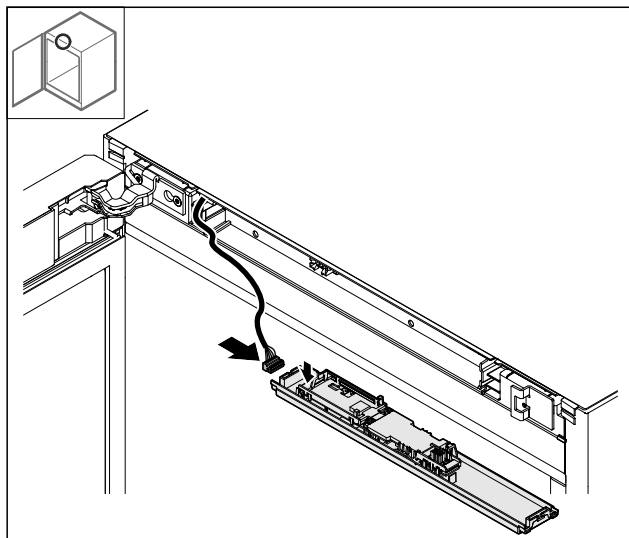

Fig. 48

► Insert the plug.

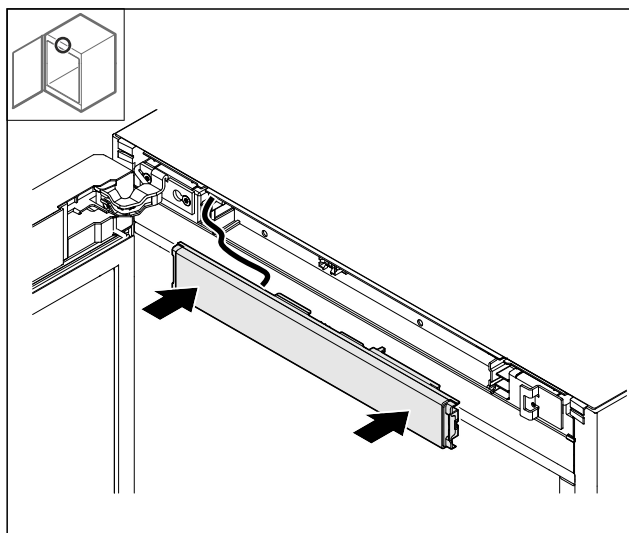

Fig. 49

► Press on the faceplate.

3.5.19 Putting on the covers

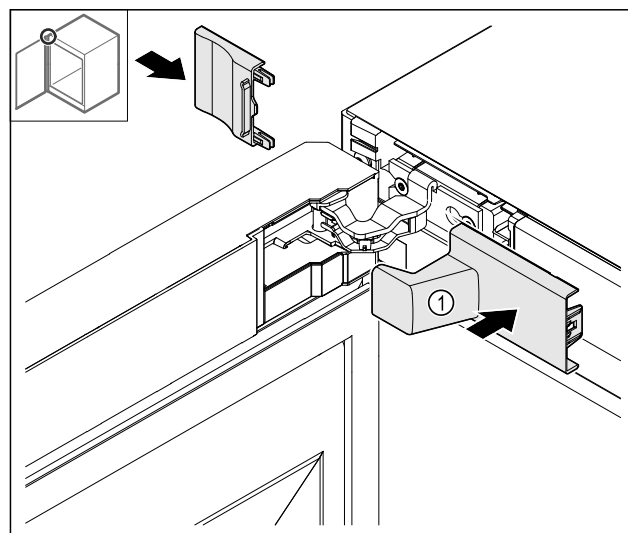

Fig. 50

(1) Cover is included in the scope of the delivery of the appliance.

► Put on the covers.

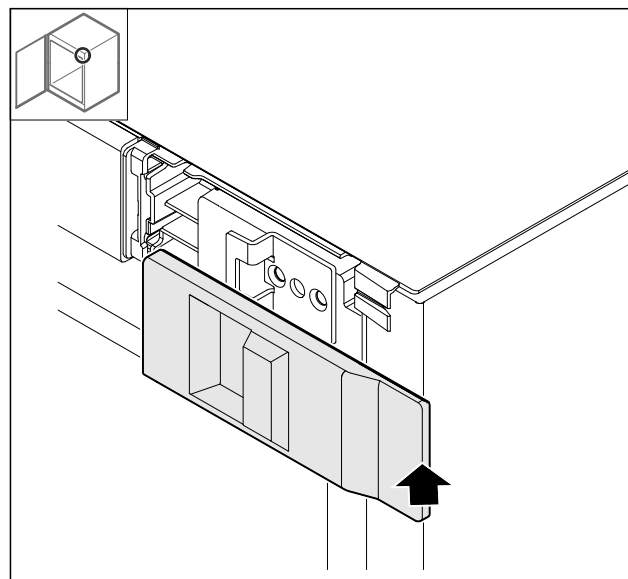

Fig. 51

► Put on the cover.

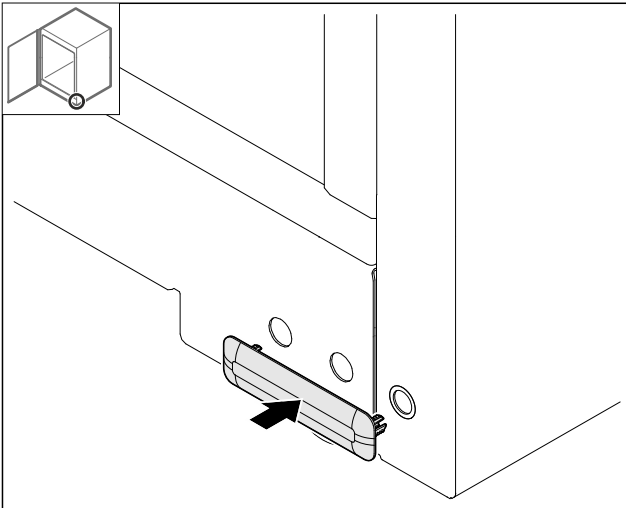

Fig. 52

- ▶ Put on the cover.

3.5.20 Mounting the worktop*

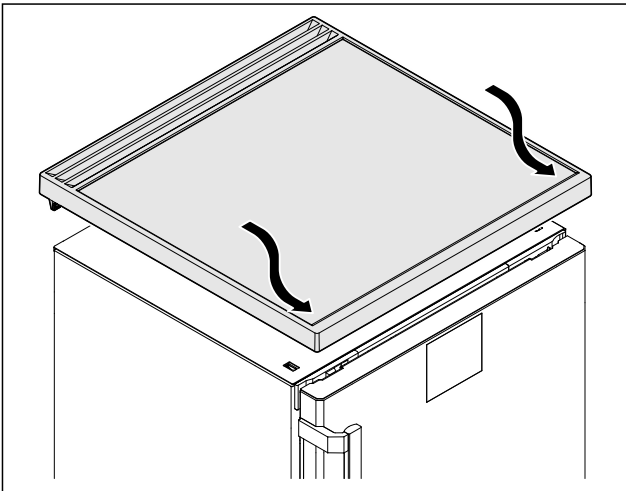

Fig. 53

- ▶ Set down the worktop.

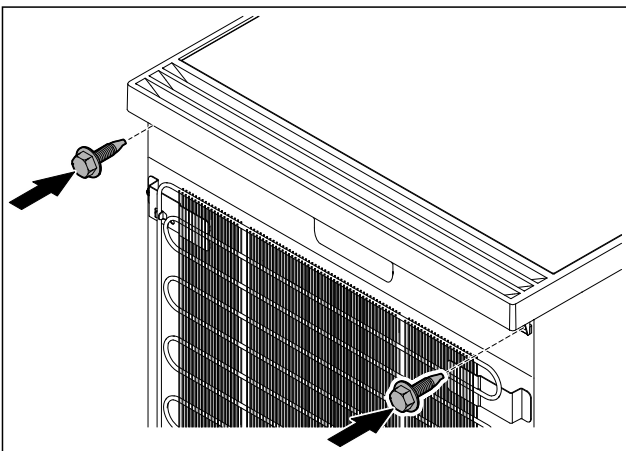

Fig. 54

- ▶ Screw down the worktop.

3.6 Aligning the door

If the door is not straight, you can adjust it on the lower hinge.

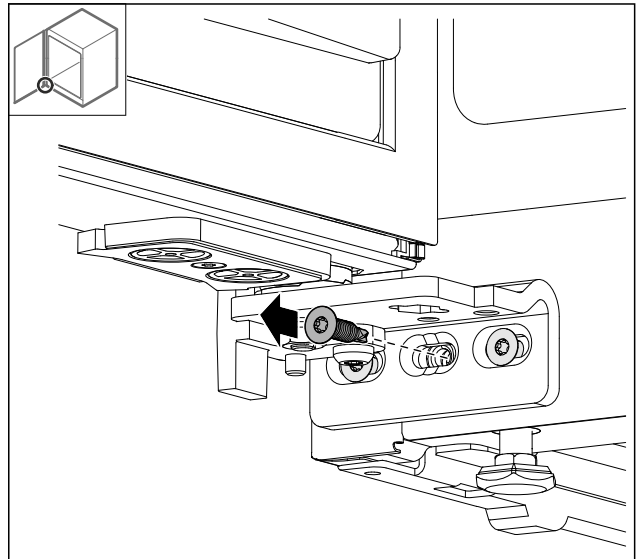

Fig. 55

- ▶ Remove the middle screw on the lower hinge.

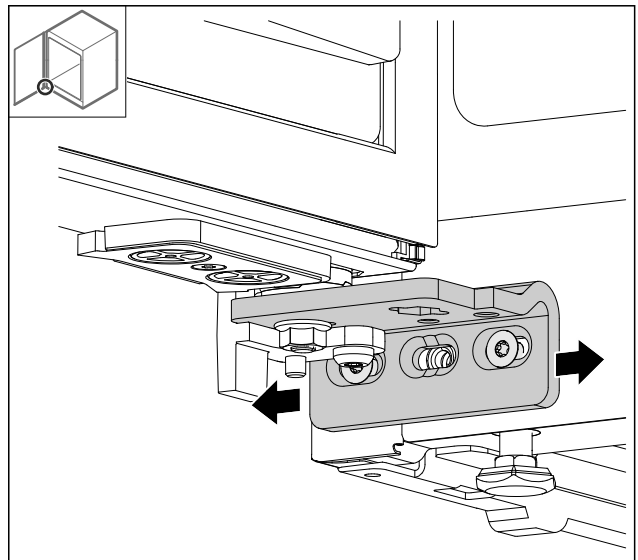

Fig. 56

- ▶ Slightly undo both screws and move the door with the hinge to the left or right.
- ▶ Fully tighten the screws (the middle screw is no longer needed).
- ▶ The door is now straight.

Setting up and connecting

3.7 Installing the door handle

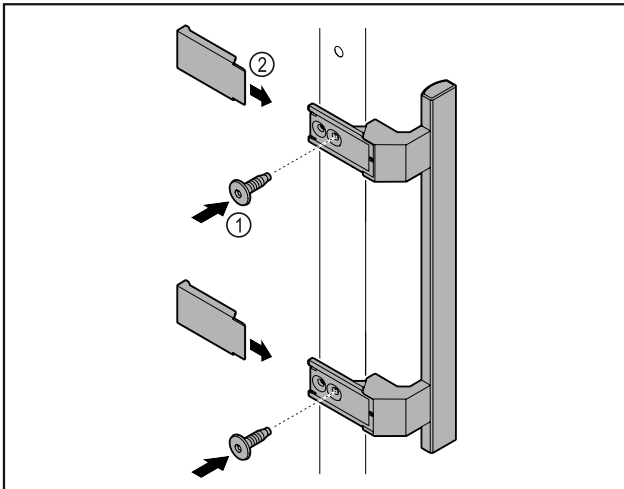

Fig. 57

- ▶ Attach handle from accessory kit to the door using supplied screws Fig. 57 (1).
- ▶ Put on cover Fig. 57 (2).
- ▶ Insert the plug from the enclosed package on the other side. *

3.8 Setting up the appliance



CAUTION

Risk of injury and damage.

- ▶ Use 2 people to set up the appliance.



CAUTION

Risk of injury and damage.

The door can strike against the wall and become damaged as a result. In the case of glass doors, the damaged glass can cause injuries.

- ▶ Protect the door from striking against the wall. Attach a door stopper, e.g. felt stopper, to the wall.

- ▶ Connect all necessary components (e.g. power cable) to the back of the appliance and route to the side.

Note

Cables can be damaged.

- ▶ Do not crush the cable when pushing the appliance back.

3.9 Leveling out the appliance

NOTICE

Appliance body can become deformed and door will not close.

- ▶ Align appliance horizontally and vertically.
- ▶ Compensate for uneven floors using adjustable feet.



WARNING

Incorrect height adjustment of the adjustable foot! Severe or fatal injuries. Incorrect height adjustment can cause the bottom part of the adjustable foot to come loose and the appliance to tip over.

- ▶ Do not unscrew the adjustable foot too far.

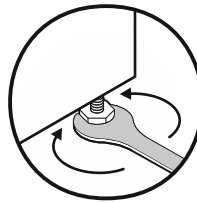

Fig. 58

Raising appliance:

- ▶ Turn adjustable foot clockwise.

Lowering appliance:

- ▶ Turn adjustable foot counterclockwise.

3.10 Setting up multiple appliances

NOTICE

Risk of damage due to condensation between the side walls.

- ▶ Do not set up the appliance directly next to another refrigeration appliance.
- ▶ Set up appliances with a space of 3 cm (1.18 in) between appliances.
- ▶ Only set up multiple appliances up to temperatures of 35 °C (95 °F) and 65 % humidity next to one another.
- ▶ At higher levels of humidity, increase the space between appliances.

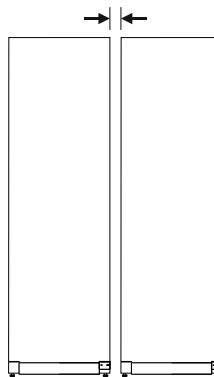

Fig. 59 Side-by-side set up

Note

A side-by-side kit is available as an accessory via Liebherr Customer Service. (see 10.3 Customer Service)

3.11 Pushing the appliance under a countertop

You can push table appliances with a maximum appliance height of 850 mm (2.79 ft) under a continuous countertop.

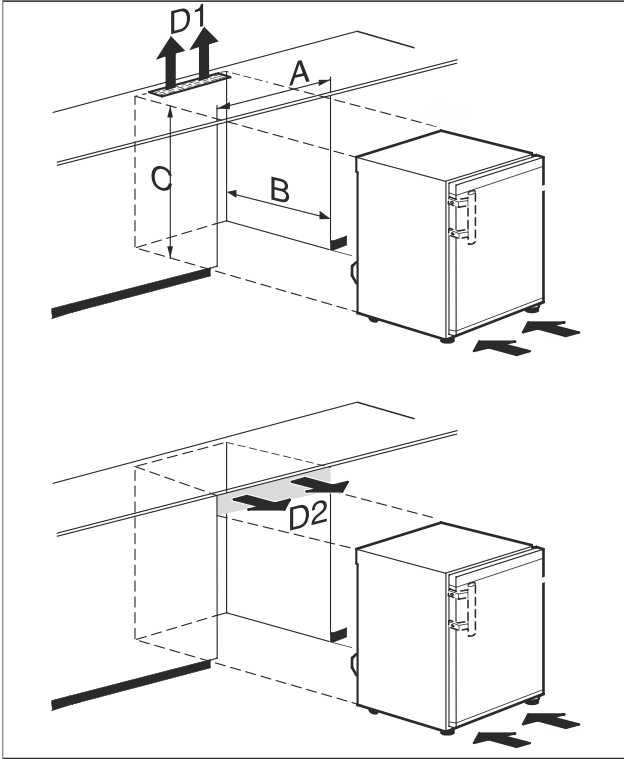

Fig. 60

(A) Appliance width without tabletop

(D1) Ventilation cross-section in the countertop

(B) Recess depth

(D2) Ventilation cross-section between countertop and appliance

(C) Recess height

A	At least 600 mm (23 1/2 in)
B	At least 550 mm (21 11/16 in)
C	At least 825 mm (32 1/2 in)
D1 or D2	At least 200 cm ² (31 in ²)

WARNING

Risk of fire from short circuit!

- ▶ When setting up the appliance: Do not kink, trap, or damage the power cable.
- ▶ Do not operate the appliance with a defective power cable.

Make sure that the following requirements are fulfilled:

- The tabletop has been removed.
- Outlet is easily accessible and is not behind the appliance.
- ▶ Push the appliance under the countertop.

3.12 After setup

- ▶ Peel off the protective films. *
- ▶ Clean the appliance. (see 9.3 Cleaning the appliance)
- ▶ If necessary: Disinfect the appliance.
- ▶ Keep the invoice so you have the appliance and dealer information available if needed.

3.13 Disposal of packaging

WARNING

Danger of suffocation from packaging materials and films!

- ▶ Do not allow children to play with packaging materials.

The packaging is made from recyclable materials:

- Corrugated card/cardboard
- Parts made of foamed polystyrene
- Films and bags from polyethylene
- Packing bands from polypropylene
- Wood frame nailed together with a polyethylene window*
- ▶ Take the packaging material to an official collection point.

3.14 Connecting the appliance to the power supply

WARNING

Danger of electric shock and injury due to damaged appliance or damaged mains cable!

Cuts and fatal injury. If the appliance or the mains cable is damaged during transport, you may be electrocuted. You could also cut yourself on damaged parts of the appliance housing.

- ▶ Check the appliance and the mains cable for damage after transport.
- ▶ Never put the appliance into operation if the appliance or the mains cable are damaged.
- ▶ Contact Customer Service.

You can connect your appliance to the mains using the power cable supplied separately. The mains power cable has an appliance coupler at one end and a mains plug at the other end.

Make sure that the following requirements are fulfilled:

- The appliance and power cable are undamaged.

Functionality of the Touch display

- The appliance is set up in accordance with the regulations. (see 3.7 Installing the door handle)
- Requirements for the electrical connection are met. (see 3.1 Installation conditions)
- Dimensions for connection in accordance with regulations are known and observed.
- Mains voltage and frequency correspond to the specifications on the type plate.
- The socket is grounded and fused in accordance with regulations.
- The tripping current for the fuse is between 10 A and 16 A.
- Outlet is easily accessible and is not behind the appliance.

NOTICE

Danger of damage to incorrect operation!
Damage to the electrical components of the appliance.
▶ Only use the supplied power cable.



WARNING

Danger of fire due to incorrect connection!
Burns.
Damage to the appliance.
▶ Do not use an extension cord.
▶ Do not use a multipoint connector strip.

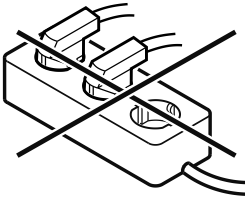

NOTICE

- Danger of damage to incorrect connection!
Damage to the appliance.
- ▶ Do not connect the appliance to a stand-alone inverter, e.g. solar power systems and petrol generators.
 - ▶ Connect the mains plug of the power cord to the power supply. Ensure the main plug is firmly plugged into the outlet.
 - ▶ If no action is taken within 60 seconds: Standby symbol fades or disappears.
 - ▶ Appliance is connected. For initial commissioning, see the next chapter or the operating instructions.

4 Functionality of the Touch display

You operate your appliance using the Touch display. You select appliance functions in the Touch display (hereafter referred to as display) by tapping them. If you do not perform any action on the display for 10 seconds, the display either jumps back to the higher-level menu or directly to the status display.

4.1 Navigation and symbol explanation

In the illustrations, different symbols are used to navigate the display. The following table describes these symbols.

Symbol	Description
	Press the Next navigation arrow: Navigates to the next option in the menu.
	Press the Back navigation arrow: Jumps back one option in the menu.
	Press and hold the Back navigation arrow for 3 seconds: Jumps back to the status display in the main menu or from the Settings menu.
	Press the navigation arrow several times in succession: Navigates in the menu to the desired function.
	Press the Confirm symbol: Activates/deactivates function. Opens submenu.
	Press the Confirm symbol together with the back icon: Jumps back one menu level.
	Arrow with clock: It takes more than 10 seconds for the following message to appear in the display.
	Arrow with a time indication: It takes the specified amount of time until the following message appears in the display.

Functionality of the Touch display

Symbol	Description
	<p>“Open Settings menu” symbol:</p> <p>Navigates to the Settings menu and opens the settings menu.</p> <p>If necessary: Navigate to the desired function in the Settings menu.</p> <p>(see 4.2.1 Opening the Settings menu)</p>
	<p>“Open Advanced menu” symbol:</p> <p>Navigates to the Advanced menu and opens the advanced menu.</p> <p>If necessary: Navigate to the desired function in the Advanced menu.</p> <p>(see 4.2.2 Opening the Advanced menu)</p>
No action for 10 seconds	If you do not perform any action on the display for 10 seconds, the display either jumps back to the higher-level menu or directly to the status display.
Opening door and closing it again	If you open the door and immediately close it again, the display jumps directly back to the status display.

Note: Illustrations of the display are shown in the English version.

4.2 Menus

The appliance functions can be found in various menus.

Menu	Description
Main menu	When you switch the appliance on, you are automatically in the main menu. From here you can navigate to the most important appliance functions, to the Settings menu and to the Advanced menu.
 Settings menu	The Settings menu contains additional appliance functions for setting up your appliance. (see 4.2.1 Opening the Settings menu)

Menu	Description
 Advanced menu	The advanced menu contains special appliance functions for setting up your appliance. Access to the Advanced menu is protected by the numerical code 151 . (see 4.2.2 Opening the Advanced menu)

4.2.1 Opening the Settings menu

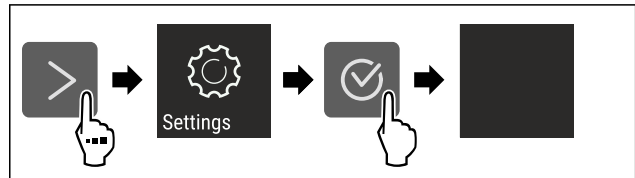

Fig. 61 Example illustration

- ▶ Carry out action steps according to the illustration.
- ▶ Settings menu is open.
- ▶ If necessary: Navigate to the desired function.

4.2.2 Opening the Advanced menu

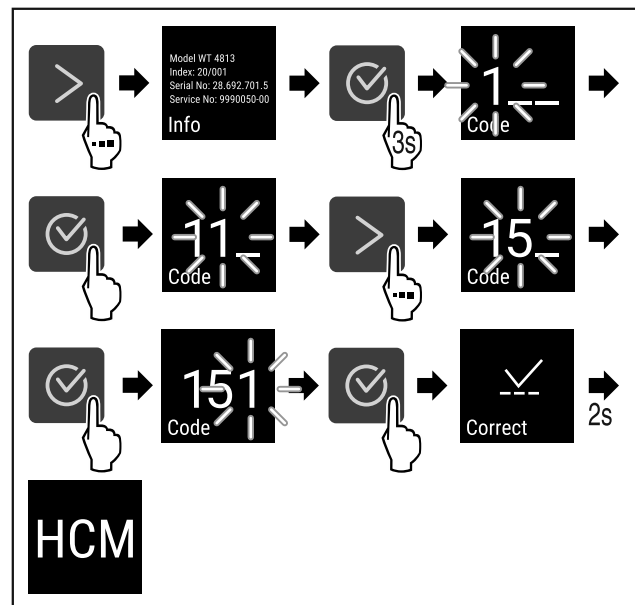

Fig. 62 Access with numerical code **151**

- ▶ Carry out action steps according to the illustration.
- ▶ Expanded menu is open.
- ▶ If necessary: Navigate to the desired function.

4.3 Sleep mode

If you do not touch the display for 1 minute, the display switches to sleep mode. In sleep mode, the display brightness is dimmed.

4.3.1 Ending sleep mode

- ▶ Press any navigation key.
- ▶ Sleep mode is ended.

Start-up

5 Start-up

5.1 Switching on the appliance (first use)

Make sure that the following requirements are fulfilled:

- Appliance is set up and connected.
- All adhesive strips, adhesive and protective films and transport locks are removed from inside and outside the appliance.



Fig. 63 Example illustration

The standby symbol flashes until the startup process is complete.

The standby symbol is shown in the display.

If the appliance has been supplied with factory settings, the screen language first needs to be selected when using for the first time.

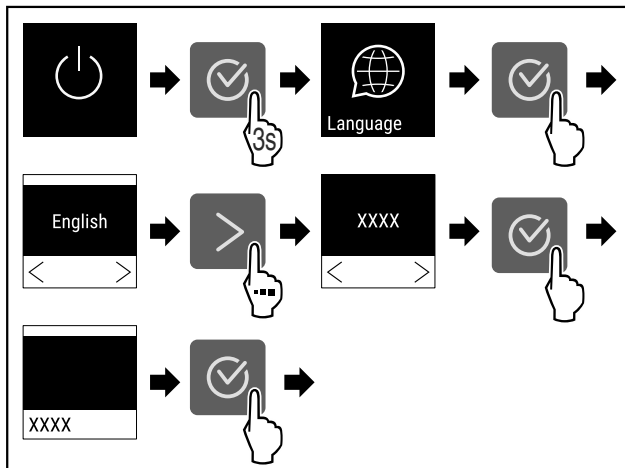

Fig. 64

- Carry out action steps according to the illustration.

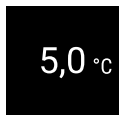

Fig. 65

- The appliance is switched on once the temperature appears on the display.
- The temperature display flashes until the set temperature is reached.

6 Storage

6.1 Information regarding storing items

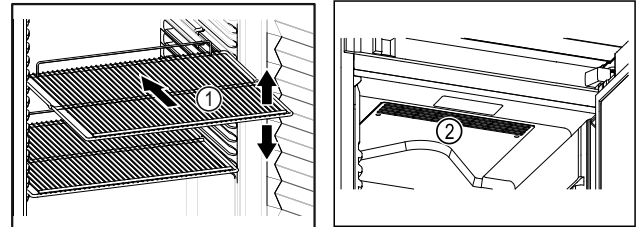

Fig. 67

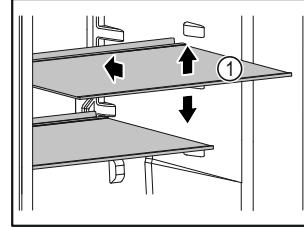

Fig. 66 Example illustration

When stocking items, observe the following:

- If shelves Fig. 66 (1) can be moved, adjust the shelves according to the height.
- Observe maximum load weight. (see 10.1 Technical data)
- Do not stock appliance until the storage temperature has been reached (maintain cold chain).
- Ventilation slots Fig. 67 (2) for recirculation fan in the interior must be kept clear.
- Refrigerated goods must not touch the rear wall.
- Refrigerated goods do not stick out beyond the shelves.
- Keep liquids in closed containers.
- Leave space when storing items for refrigeration to ensure adequate air circulation.
- Do not stack refrigerated products above the indicated height.

This is important for free air circulation and even temperature distribution in the interior.

7 Use

7.1 Control and display elements

The display provides a quick overview of the current appliance status, the temperature setting, the status of functions and settings as well as alarm and error messages.

It is operated using the navigation arrows and confirmation symbol.

Functions can be activated or deactivated and settings values can be changed.

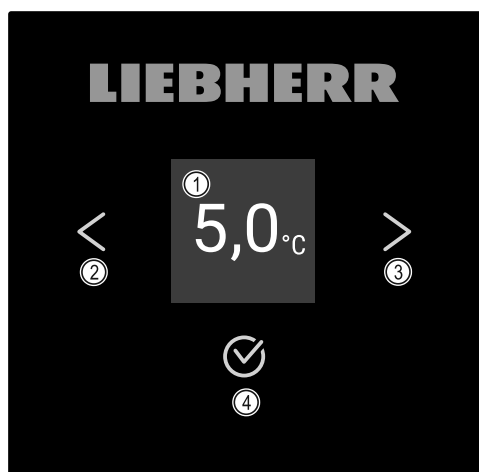

Fig. 68 Display

- (1) Status display
 (2) Back navigation arrow
 (3) Forward navigation arrow
 (4) Confirm

7.1.1 Status display



Fig. 69 Status display with actual temperature

The status display shows the actual temperature and is the home display. You navigate from here to the other functions and settings. The status display may show a range of display symbols.

7.1.2 Display symbols

The display symbols provide information about the current status of the appliance.

Symbol	Appliance status
	Standby Appliance is switched off.
	Flashing standby symbol Appliance is starting up.
	Flashing temperature Target temperature not yet reached. Appliance cooling to set temperature.
	Temperature display Displays the current interior temperature.

Symbol	Appliance status
	Display alternating between temperature/defrost symbol with white bar Appliance is in manual defrosting mode.
	D in the display Appliance is in DemoMode.
	Maintenance reminder The time set interval has expired.
	Data memory full The data memory (999 hours) is full. From now, the oldest data will be overwritten.
	Flashing symbol A fault is still present.
	Error symbol Appliance is still malfunctioning.
	White bar at the bottom Submenu
	White bar at the top Default, active setting or active value.
	Increasing bar Press button for 3 seconds to activate setting.
	Decreasing bar Press button for 3 seconds to deactivate setting.

Status display symbols

7.1.3 Acoustic signals

A signal sounds in the following cases:

- If a function or a value is confirmed.
- If a function or a value can neither be activated nor deactivated.
- As soon as a fault occurs.
- If there is an alarm message.

The alarms can be switched on and off in the customer menu.

Use

7.2 Appliance functions

7.2.1 Notes on the appliance functions

The appliance functions are set at the factory so that your appliance is fully functional.

Before you alter, activate or deactivate the appliance functions, make sure that the following requirements are met:

- ❑ You have read and understood the descriptions of how the display works. (see 4 Functionality of the Touch display)
- ❑ You have familiarized yourself with the operating and display elements of your appliance. (see 7.1 Control and display elements)

7.2.2 Switching appliance on and off



Using this setting the entire appliance can be switched on and off.

Switching on the appliance

Without activated DemoMode:



Fig. 70

- ▶ Carry out action steps according to the illustration.

With activated DemoMode:

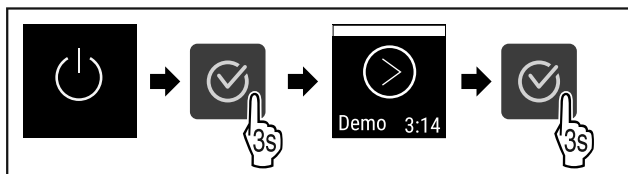

Fig. 71

- ▶ Carry out action steps according to the illustration.

Note

Deactivate DemoMode before the countdown finishes.

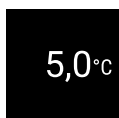

Fig. 72

- ▶ The temperature appears on the display.

Switching off the appliance



Fig. 73

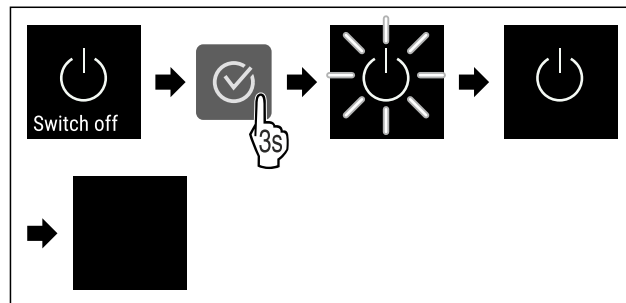

Fig. 74

- ▶ Carry out action steps according to the illustration.
- ▶ Standby symbol is shown in the display.
- ▶ Display switches off after approximately 10 minutes.

7.2.3 Temperature



The temperature depends on the following factors:

- How often the door is opened
- How long the door is open for
- The room temperature of the installation site
- The type, temperature and amount of refrigerated items

Note

The temperature may differ from the temperature displayed in some areas of the interior.

Setting the temperature

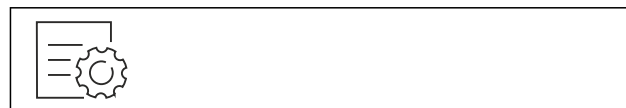

Fig. 75

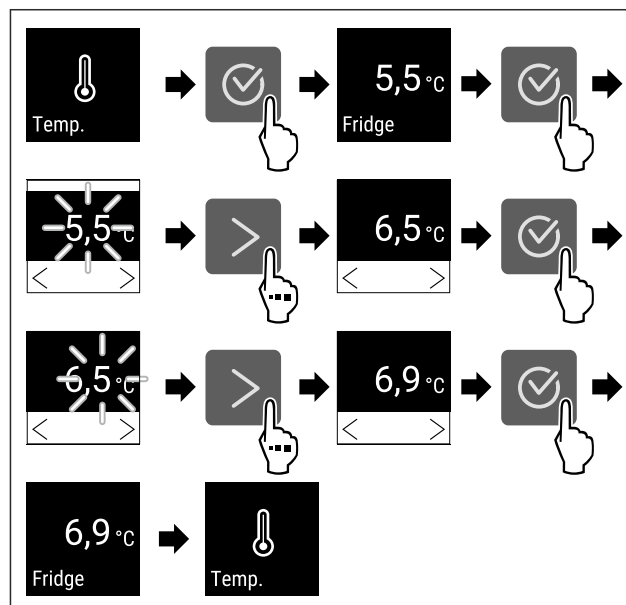

Fig. 76 Changing temperature from 5.5 °C (42 °F) to 6.9 °C (44 °F)

- ▶ Carry out action steps according to the illustration.

► Temperature is set.

7.2.4 Temperature recording

The appliance displays the minimum and maximum temperatures of the interior. The recording of these temperatures starts automatically after the appliance is switched on; they are recorded at one minute intervals. A note indicating that the data memory is full is displayed after 999 hours (approx. 40 days). The temperature recording should then be reset.

Note

We recommend resetting the temperature recording once **after reaching the set temperature** when the appliance is commissioned. This ensures that the value displayed for the maximum temperature is a meaningful value.

Displaying temperature recording

The temperature recording displays the length of the recording and the minimum and maximum temperatures measured during this period of time.

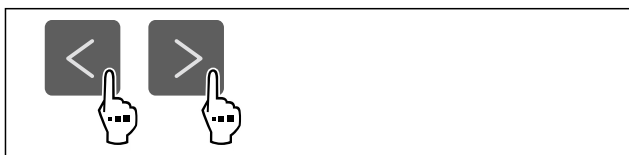

Fig. 77

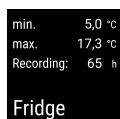

Fig. 78

► Status screen with the temperature recordings is displayed.

Resetting temperature recording

The displayed minimum and maximum temperatures can be reset at any time. This deletes the displayed values and the recording interval starts again.

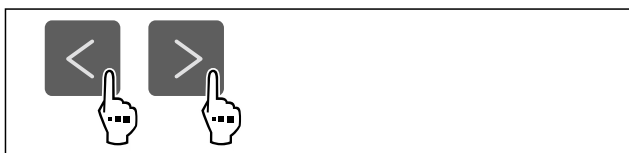

Fig. 79

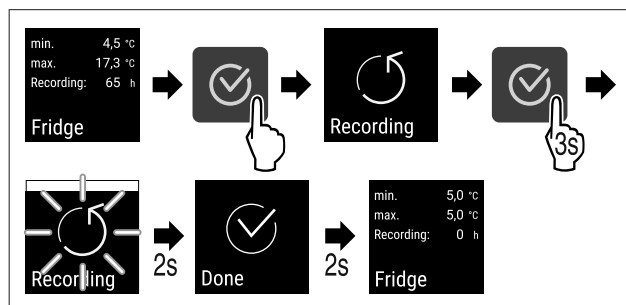

Fig. 80

- Carry out steps according to the illustration.
- Temperature recording is reset.
- Reminder interval is reset.

7.2.5 Lighting *

The appliance is equipped with interior lighting.

You can keep the interior lighting on continuously. (see Switching on lighting*) *

When you open the appliance door, the interior lighting switches on.

Switching off lighting*



Fig. 81

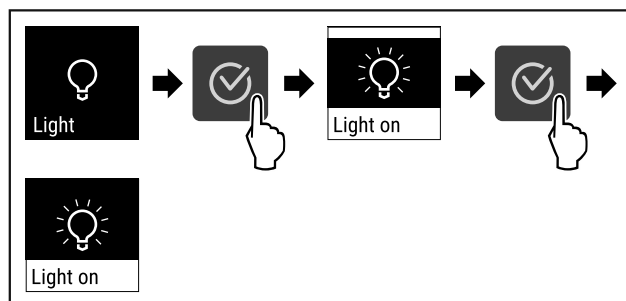

Fig. 82

- Carry out action steps according to the illustration.
- Lighting is switched off.

Switching on lighting*



Fig. 83

Use

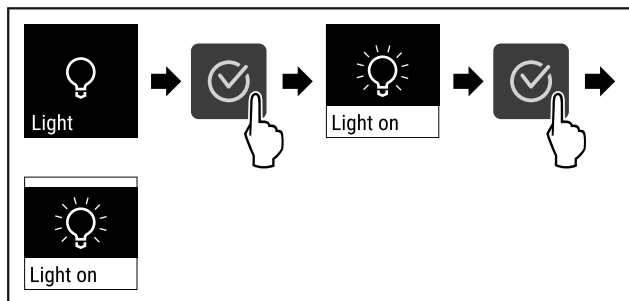

Fig. 84

- ▶ Carry out action steps according to the illustration.
- ▶ Lighting is switched on.

7.2.6 Settings menu access protection

This setting enables the settings menu access protection via a three-digit PIN code.

Application:

- Prevent settings and functions being changed unintentionally.
- Prevent the appliance from being switched off unintentionally.
- Avoid unintentional temperature adjustment.

Note

- ▶ In the following examples, the PIN code set at the factory: **1 1 1** is used.

Activating the settings menu access protection

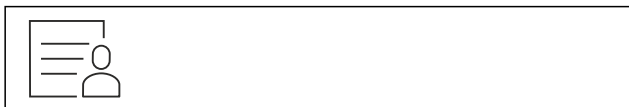

Fig. 85

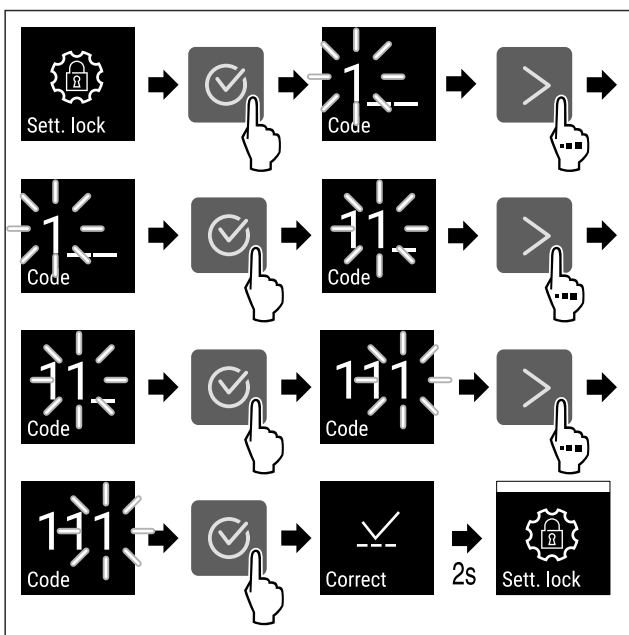

Fig. 86

- ▶ Carry out action steps according to the illustration.
- ▶ Settings menu access protection is activated.

Changing the access protection PIN code for the settings menu

See: (see 7.2.7 Access codes)

Deactivating the settings menu access protection



Fig. 87

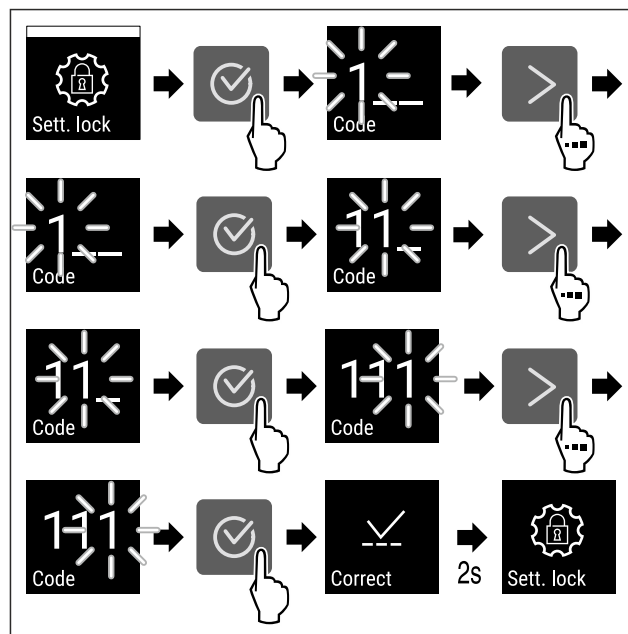

Fig. 88

- ▶ Carry out action steps according to the illustration.
- ▶ Settings menu access protection is deactivated.

Opening protected settings menu

A PIN code must be entered to open the settings menu if the access security is enabled. Access security is enabled automatically as soon as you exit the settings menu.

- ▶ Tap navigation arrow repeatedly until corresponding function is displayed.

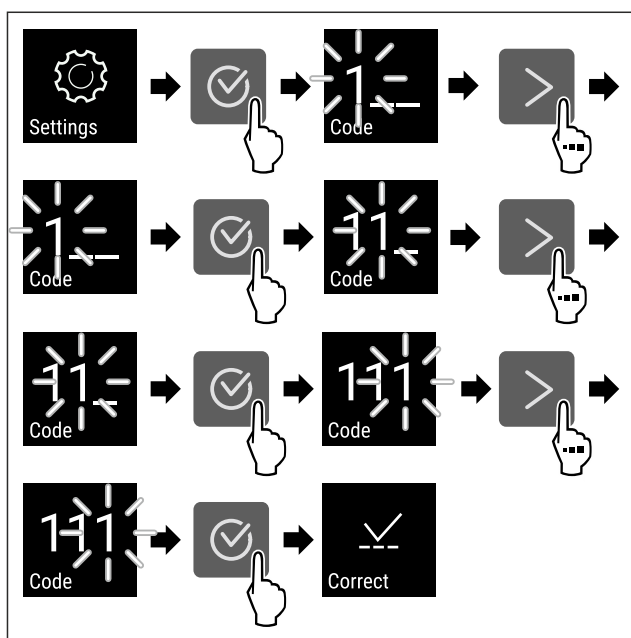

Fig. 89

- ▶ Carry out action steps according to the illustration.
- ▶ The PIN code is correct.
- ▶ The settings menu opens.

7.2.7 Access codes

Various settings are possible.

Application:

- Changing the settings code.
- Resetting the settings code.

Settings menu access protection



Changing the settings code

This setting allows the settings code for settings menu access protection to be changed.

The setting is made in 3 stages:

- Entering the old settings code
- Entering the new settings code
- Confirming the new settings code

Note

- ▶ In the following example, the default factory-set settings code **1 1 1** is changed.
- ▶ The new settings code is: **2 3 4**



Fig. 90

The access protection for the settings menu must be active. (see 7.2.6 Settings menu access protection)

- ▶ Press the navigation arrow repeatedly until the corresponding function is displayed.

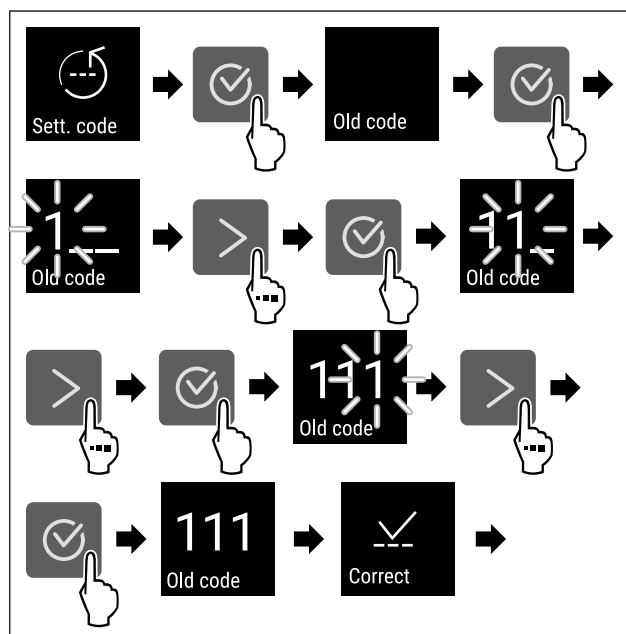

Fig. 91

- ▶ Carry out action steps according to the illustration.
- ▶ Entry of the old settings code successful.

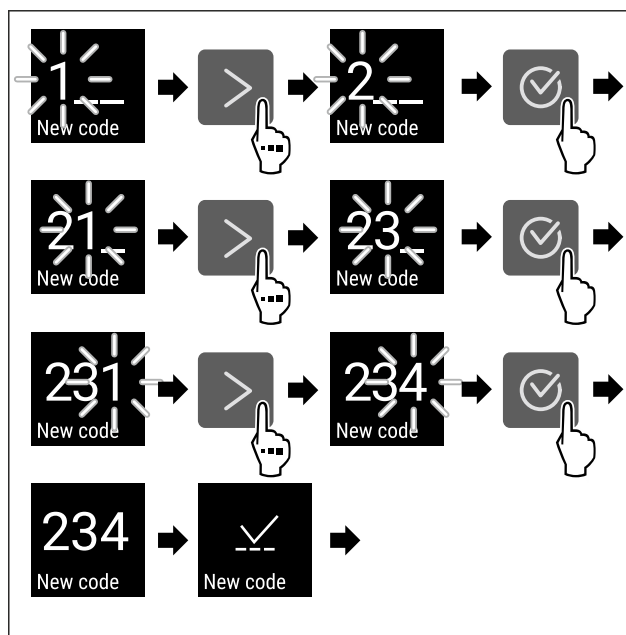

Fig. 92

- ▶ Carry out action steps according to the illustration.
- ▶ Entry of the new settings code successful.

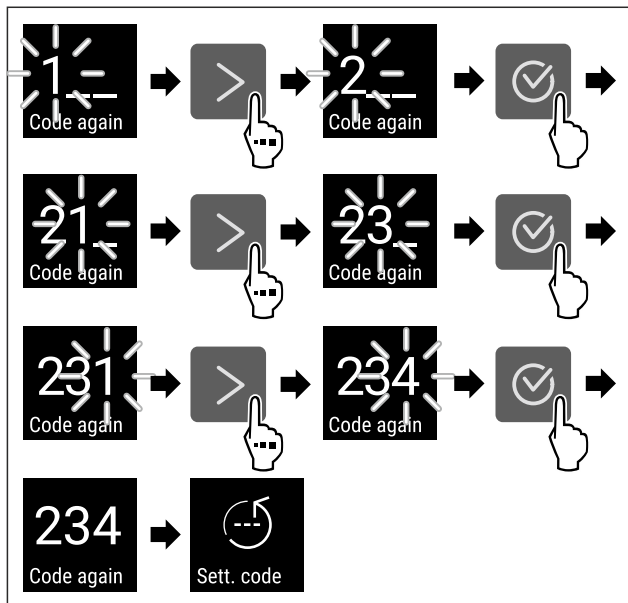

Fig. 93

- ▶ Carry out action steps according to the illustration.
- ▶ Confirmation of the new settings code.
- ▶ The settings code has been changed.

Resetting the settings code

The settings code for the settings menu access protection has been forgotten or is not known.

- ▶ Reset the appliance to factory settings (see 7.2.27 Resetting to factory settings).
- ▶ The appliance is reset to the original settings.
- ▶ The factory-set settings code is: **1 1 1**

7.2.8 Maintenance interval reminder

Setting for the time interval after which a maintenance reminder is issued.

The following values can be set:

- 7 days
- 14 days
- 30 days
- 60 days
- 90 days
- 180 days
- 360 days
- 720 days
- 1080 days
- Off

Setting maintenance interval reminder

The following steps describe how the maintenance interval is set.

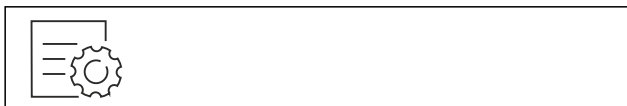

Fig. 94

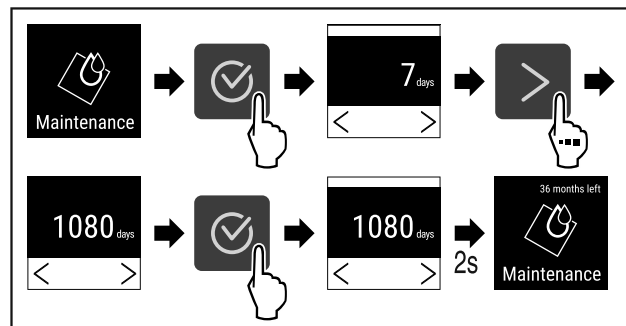

Fig. 95

- ▶ Carry out action steps according to the illustration.
- ▶ The time interval, after which the maintenance reminder is issued, is set.
- ▶ The remaining time is displayed.

7.2.9 Language

This setting allows the display language to be set.

Setting the language



Fig. 96

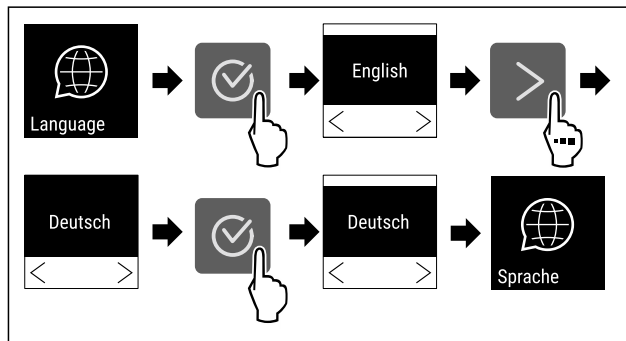

Fig. 97

- ▶ Carry out action steps according to the illustration.
- ▶ The selected language is set.

7.2.10 Temperature unit

Use this function to set the temperature unit. You can set the temperature unit in either degrees Celsius or degrees Fahrenheit.

Setting the temperature unit



Fig. 98

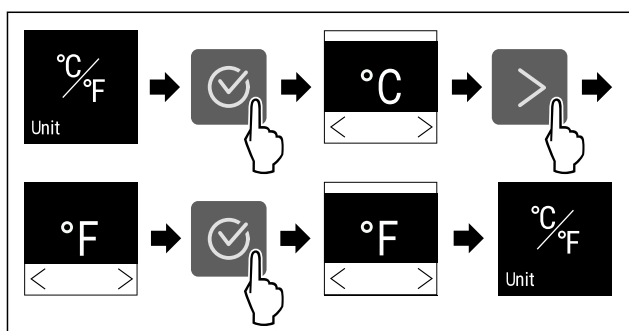

Fig. 99 Example illustration: Switching between degrees Celsius or degrees Fahrenheit.

- ▶ Carry out action steps according to the illustration.
- ▶ Temperature unit is set.



7.2.11 Display Brightness

Use this function to set the brightness of the display gradually.

You can set the following brightness levels:

- 40 %
- 60 %
- 80 %
- 100% (default setting)

Setting the brightness

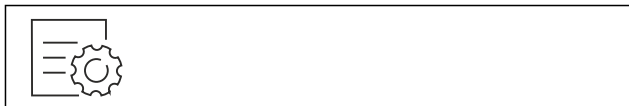

Fig. 100

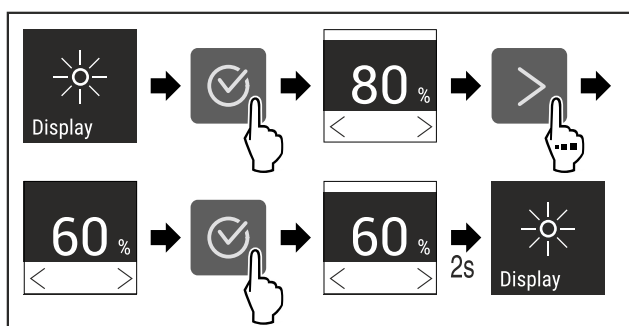

Fig. 101 Example illustration: Switching from 80% to 60%.

- ▶ Carry out action steps according to the illustration.
- ▶ Brightness is set.



7.2.12 Alarm Sound

This function enables all alarm sounds, such as the door alarm, to be switched on and off.

Activating Alarm Sound



Fig. 102

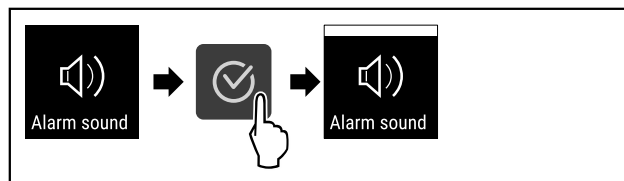

Fig. 103

- ▶ Carry out action steps according to the illustration.
- ▶ Alarm Sound is activated.

Deactivating Alarm Sound



Fig. 104

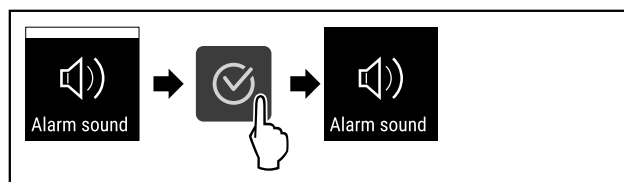

Fig. 105

- ▶ Carry out action steps according to the illustration.
- ▶ Alarm Sound is deactivated.



7.2.13 Key Sound

This function makes it possible to switch all confirmation sounds and the Startsound on and off.

Activating Key Sound



Fig. 106

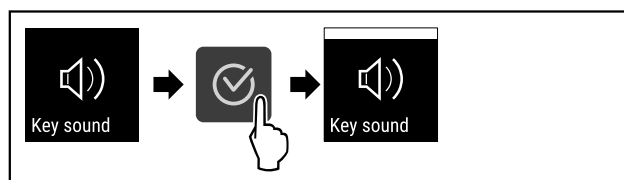

Fig. 107

- ▶ Carry out action steps according to the illustration.
- ▶ Key Sound is activated.

Use

Deactivating Key Sound



Fig. 108

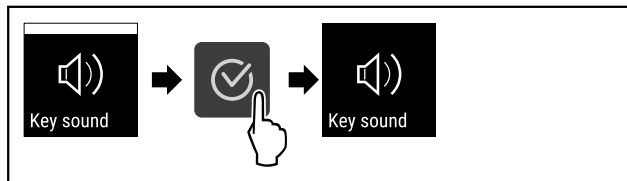

Fig. 109

- ▶ Carry out action steps according to the illustration.
- ▶ Key Sound is deactivated.

7.2.14 WiFi connection



Note

Liebherr SmartMonitoring Dashboard is not available in all countries. Check availability via the QR code by entering your model.

Note

Use of the Liebherr SmartMonitoring Dashboard at <https://smartmonitoring.liebherr.com> requires installation of a SmartModule and a commercial MyLiebherr account. When commissioning online you can register using your login data, or register again and create a company account.

This setting establishes a wireless connection between the appliance and the internet. The connection is controlled via the SmartModule. The appliance can be integrated via the browser-based [Liebherr SmartMonitoring Dashboard](#) and advanced options and customized methods relating to control, administration and monitoring can be used.

Note

Accessories are available from the Liebherr Service Center. The address for your respective country can be found on the back of the instructions.

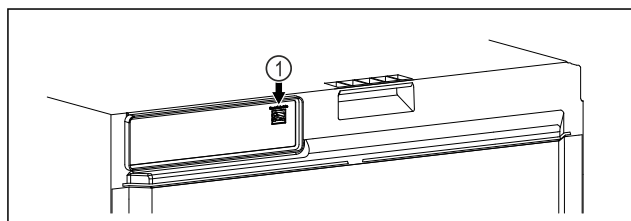

Fig. 110

Make sure that the following requirements are fulfilled:

- ❑ SmartModule Fig. 110 (1) is inserted.

Establishing a connection

You commission and set up your SmartModule online via the [Liebherr SmartMonitoring Dashboard](#) on your web-enabled device.

On the [Liebherr SmartMonitoring Dashboard](#) information is also available about retrofitting the SmartModule.



Fig. 111

- ▶ Open the [Liebherr SmartMonitoring Dashboard](#) (see Fig. 111).

On the fridge or freezer:



Fig. 112

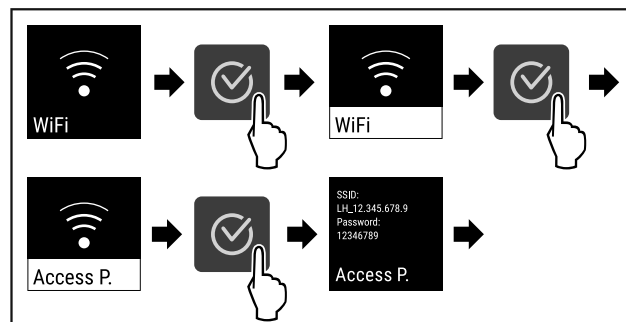

Fig. 113

- ▶ Carry out action steps according to the illustration.
- ▶ Continue the set-up procedure on your web-enabled device: [Liebherr SmartMonitoring Dashboard](#)

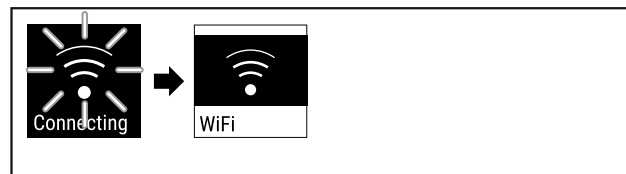

Fig. 114

- ▶ Connection is established.
- ▶ WiFi connecting appears. The symbol flashes.
- ▶ Follow the [Liebherr SmartMonitoring Dashboard](#) instructions.
- ▶ Connection is established.

Disconnecting

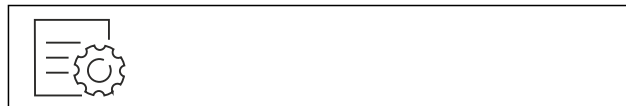

Fig. 115

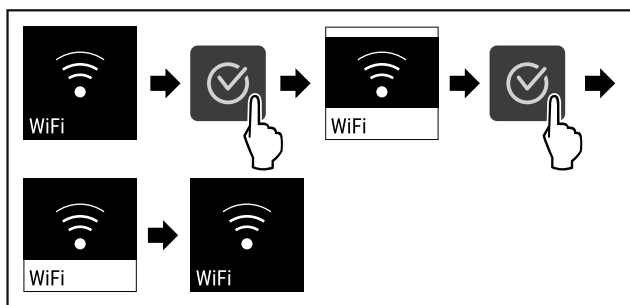

Fig. 116

- ▶ Carry out action steps according to the illustration.
- ▶ There is no connection.

Resetting connection

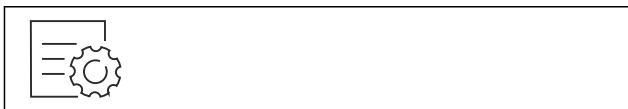

Fig. 117

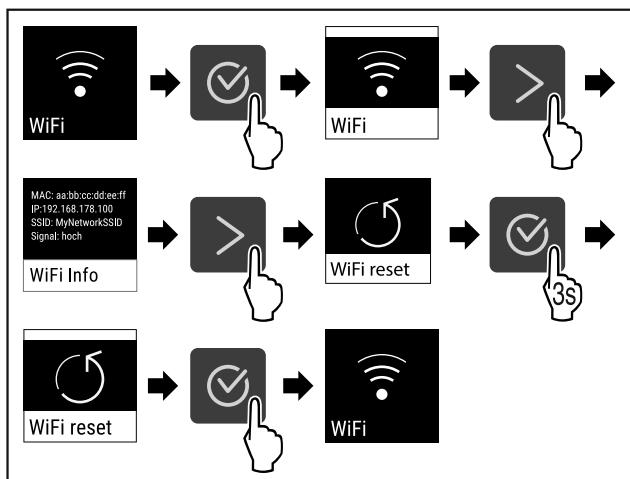

Fig. 118

- ▶ Carry out action steps according to the illustration.
- ▶ The WiFi settings are restored to the factory settings.

7.2.15 LAN connection



Note

Liebherr SmartMonitoring Dashboard is not available in all countries. Check availability via the QR code by entering your model.

Note

Use of the Liebherr SmartMonitoring Dashboard at <https://smartmonitoring.liebherr.com> requires installation of a SmartModule and a commercial MyLiebherr account. When commissioning online you can register using your login data, or register again and create a company account.

This setting establishes a wired connection between the appliance and the internet. The connection is controlled via the SmartModule. The appliance can be integrated via the browser-based [Liebherr SmartMonitoring Dashboard](#) and advanced options and customized methods relating to control, administration and monitoring can be used.

Note

Accessories are available from the Liebherr Service Center. The address for your respective country can be found on the back of the instructions.

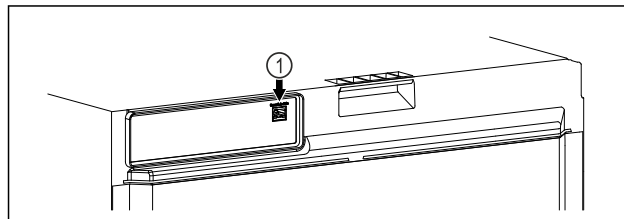

Fig. 119

Make sure that the following requirements are fulfilled:

- SmartModule Fig. 119 (1) is inserted.
- A network cable is connected.
- The network is connected to the Internet.

Establishing a connection

You commission and set up your SmartModule online via the [Liebherr SmartMonitoring Dashboard](#) on your web-enabled device.

On the [Liebherr SmartMonitoring Dashboard](#) information is also available about retrofitting the SmartModule.



Fig. 120

- ▶ Open the [Liebherr SmartMonitoring Dashboard](#) (see Fig. 120).

On the fridge or freezer:

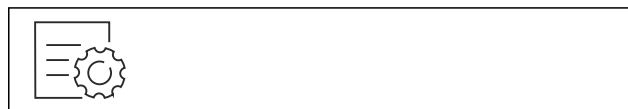

Fig. 121

Use

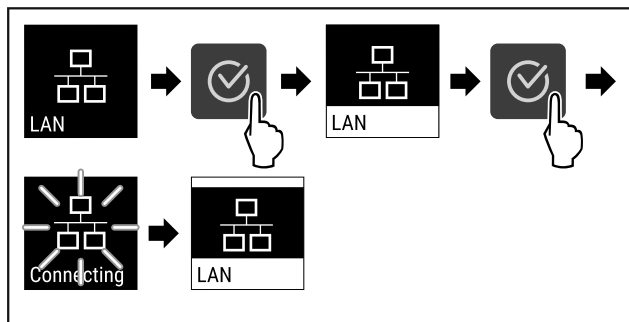

Fig. 122

- ▶ Carry out action steps according to the illustration.
- ▶ Connection is established: LAN connecting appears. The symbol flashes.
- ▶ Follow the [Liebherr SmartMonitoring Dashboard](#) instructions.
- ▶ Connection is established.

Disconnecting

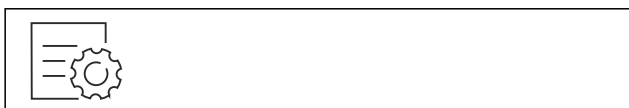

Fig. 123

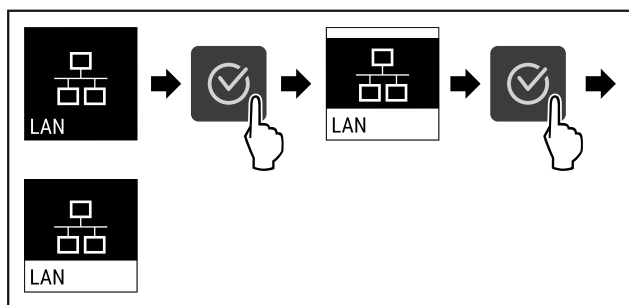

Fig. 124

- ▶ Carry out action steps according to the illustration.
- ▶ There is no connection.

7.2.16 Appliance information

Use this function to display the model name, index, serial number and service number of your appliance. You will need the appliance information when you contact customer service. (see 10.3 Customer Service)

You also use this function to open the expanded menu. (see 4 Functionality of the Touch display)

Display appliance information

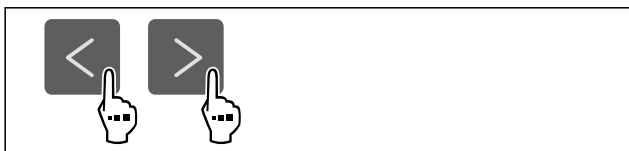

Fig. 125



Fig. 126

- ▶ Carry out action steps according to the illustration.
- ▶ Display shows the appliance information.

7.2.17 Operating hours

The display shows the appliance operating hours.

Displaying operating hours

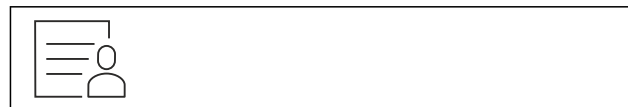

Fig. 127



Fig. 128

- ▶ The operating hours appear.

7.2.18 Software

Use this function to display the software version of your appliance.

Display software version



Fig. 129



Fig. 130

- ▶ Carry out action steps according to the illustration.
- ▶ Display indicates the software version.

7.2.19 Defrosting

The appliance defrosts automatically in normal operation.



Application:

- If heavier icing occurs inside the appliance, you can start the automatic defrosting function manually.

Starting automatic defrost manually

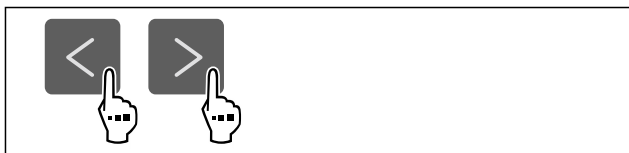

Fig. 131

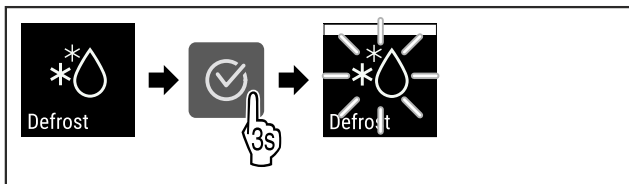

Fig. 132

- ▶ Carry out action steps according to the illustration.
- ▶ Automatic defrost has started. After defrost is complete, the appliance switches back to normal operation again.

Note

If there is still ice in the interior after several automatic defrost starts, defrost the appliance manually. (see 9.2 Defrosting the appliance)

Canceling manually started defrost



Fig. 133

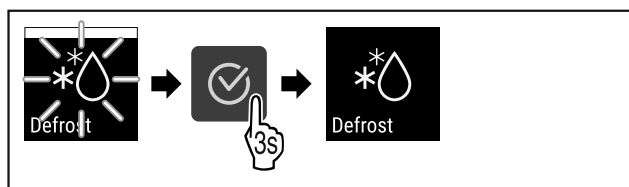

Fig. 134

- ▶ Carry out action steps according to the illustration.
- ▶ Manually started defrost is canceled. The appliance switches back to normal operation again.



The display during the automatic defrosting is adjusted with this setting.

Display	Description
Def 1	The temperature display is not updated. It shows the last temperature before automatic defrost was started.

Display	Description	
Def 2	The “automatic defrosting” symbol is displayed on the status display. The temperature display is continuously updated and shows the actual temperature.	
Def 3	As of software version PW SW less than TOD 8-800:	The temperature display is not updated. It shows the last temperature before automatic defrost was started.
	As of software version PW SW equal or more than TOD 8-800:	The temperature display is continuously updated and shows the actual temperature.
Def 4	As of software version PW SW less than TOD 8-800:	The temperature display is not updated. It shows the last temperature before automatic defrost was started.
	As of software version PW SW equal or more than TOD 8-800:	The “automatic defrosting” note is displayed on the status display. The temperature display is not updated. It shows the last temperature before automatic defrost was started.

Defrosting Note for “automatic defrosting” is shown in the status display



Here, you see the software version installed on your appliance PW SW: (see 7.2.18 Software)



Fig. 135

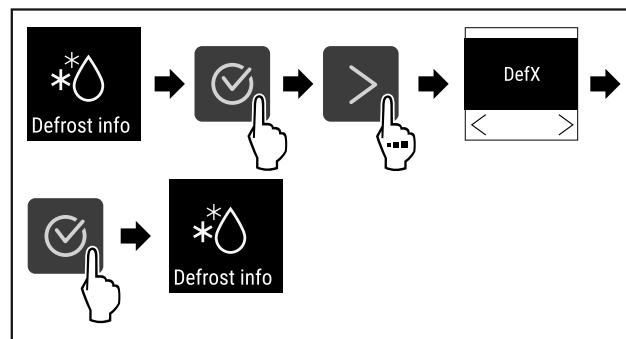

Fig. 136

- ▶ Carry out action steps according to the illustration.
- ▶ The display variant you want is selected.

7.2.20 Sensor calibration



The sensor calibration allows you to offset differences between the set and the actual temperature. To do so, determine the actual temperature using a calibrated measuring gauge.

Setting range: +/- 3 Kelvin in 0.1 Kelvin increments.

Calibrating the sensor



Fig. 137

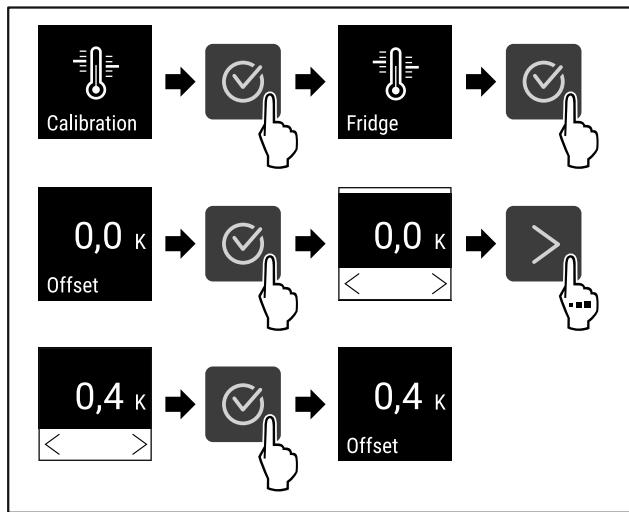

Fig. 138

- ▶ Carry out action steps according to the illustration.
- ▶ The sensor is calibrated.

Note

The calibrated temperature is shown on the display within two hours.

7.2.21 Temperature alarm



Set the temperature alarm with this function. In the process, define the upper and lower temperature limit with a differential value to the currently set interior temperature. The temperature alarm is triggered once the interior temperature leaves the set temperature range and any set delay time has expired.

For example	Differential value to be set	
Current interior temperature	5 °C 41 °F	
Lower temperature limit	2 °C 36 °F	-3 °C 27 °F

For example	Differential value to be set	
Upper temperature limit	8 °C 46 °F	+3 °C 37 °F

You can set the following values:

- Differential value for lower temperature limit in 0.1 °C (°F) intervals
- Differential value for upper temperature limit in 0.1 °C (°F) intervals
- Alarm delay time from 0 to 60 minutes (a setting of "0" does not mean there is a delay in the temperature alarm.)
- Repetition frequency of the alarm from 0 to 30 minutes after confirming the alarm (setting of "0" means no repeated alarm after confirming the alarm relay.)

Setting temperature alarm



Fig. 139

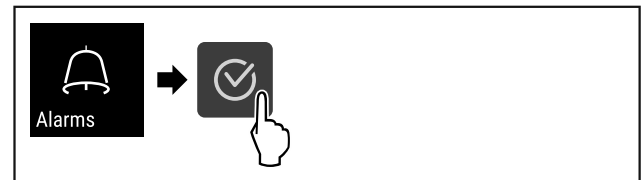

Fig. 140

- ▶ Carry out action steps according to the illustration.

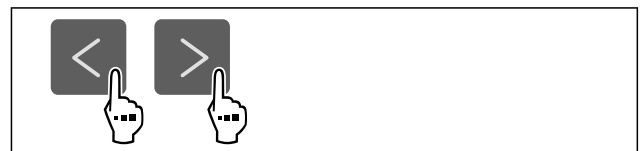

Fig. 141

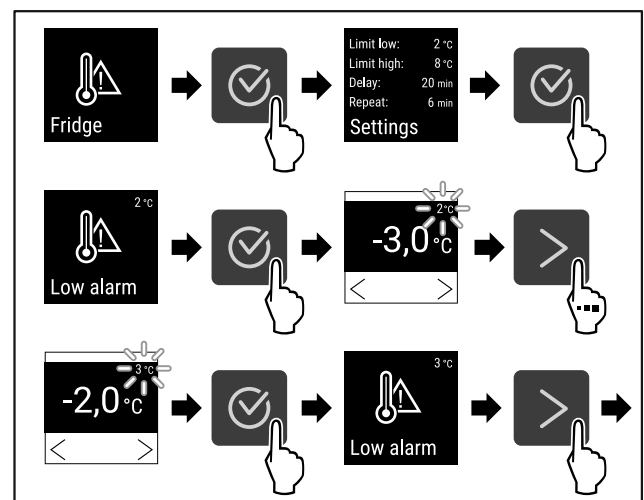

Fig. 142 Example for setting the lower temperature limit based on a set appliance temperature of 5 °C.

- ▶ Carry out action steps according to the illustration.
- ▷ Lower temperature limit has been set.

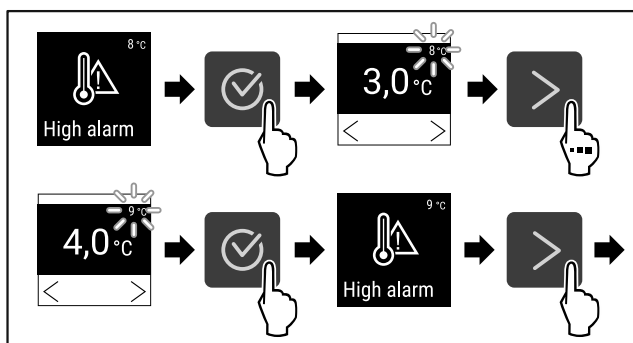

Fig. 143 Example for setting the lower temperature limit based on a set appliance temperature of 5 °C.

- ▶ Carry out action steps according to the illustration.
- ▷ Upper temperature limit has been set.

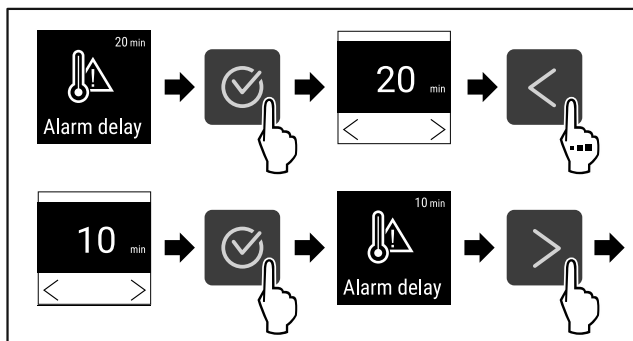

Fig. 144

- ▶ Carry out action steps according to the illustration.
- ▷ Alarm delay time has been set.

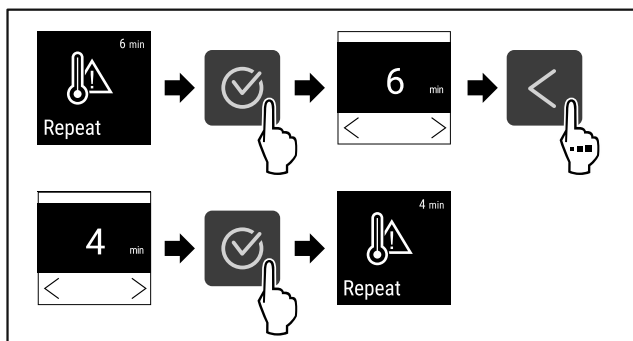

Fig. 145

- ▶ Carry out action steps according to the illustration.
- ▷ Alarm repetition interval has been set.
- ▷ Temperature alarm has been set.

Displaying set temperature alarm values



Fig. 146

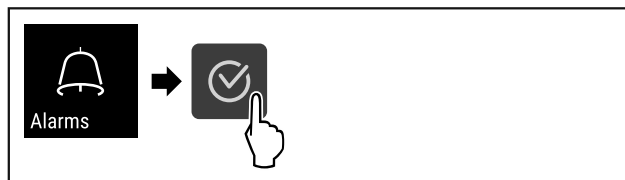

Fig. 147

- ▶ Carry out action steps according to the illustration.



Fig. 148

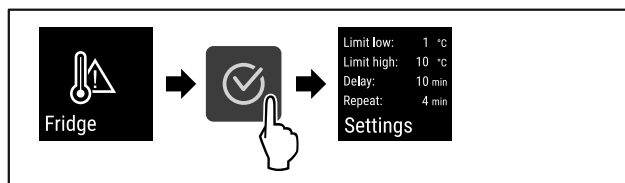

Fig. 149

- ▶ Carry out action steps according to the illustration.
- ▷ Set temperature alarm values are displayed.

7.2.22 Door alarm



Use this function to activate or deactivate the door alarm. The door alarm sounds if the door is open for too long. The door alarm is activated upon delivery. You can set how long to door can remain open until the door alarm sounds.

You can set the following values:

- 15 seconds
- 30 seconds
- 60 seconds
- 90 seconds
- 120 seconds
- 150 seconds
- 180 seconds
- Off

Setting the door alarm

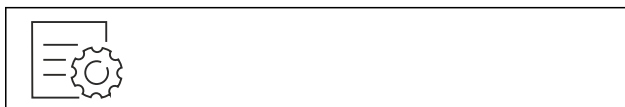

Fig. 150

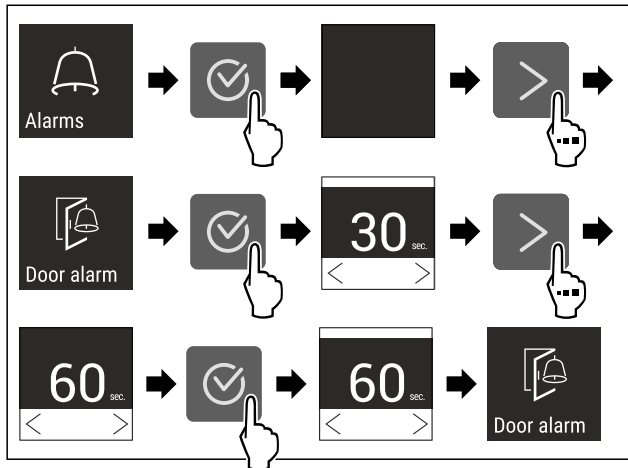

Fig. 152 Example illustration: Changing the door alarm from 30 seconds to 60 seconds.

- ▶ Carry out action steps according to the illustration.
- ▶ Door alarm is set.

Deactivating door alarm

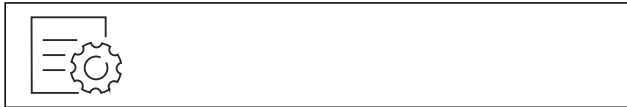

Fig. 153

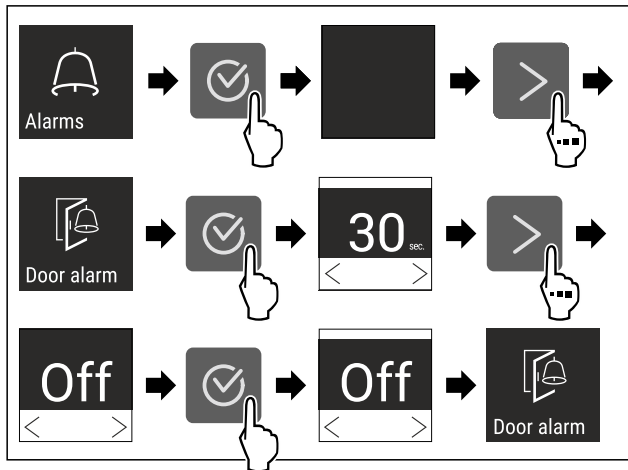

Fig. 154

- ▶ Carry out action steps according to the illustration.
- ▶ Door alarm is deactivated.

7.2.23 Light alarm



This setting allows the visual alarm messages in the display to also be emphasized by flashing appliance lighting.

Activating the light alarm

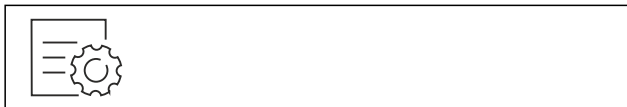

Fig. 155

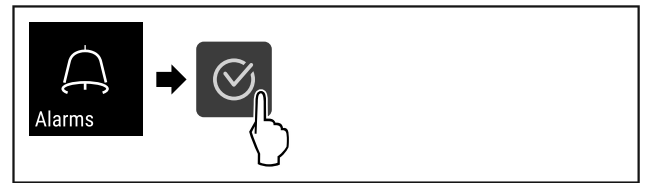

Fig. 156

- ▶ Carry out action steps according to the illustration.



Fig. 157

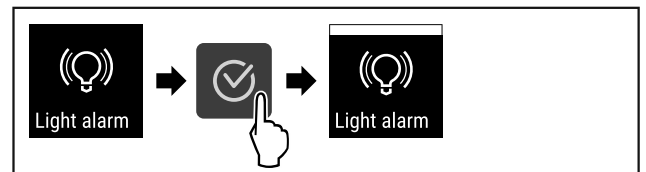

Fig. 158

- ▶ Carry out action steps according to the illustration.
- ▶ The light alarm is activated.

Deactivating the light alarm



Fig. 159



Fig. 160

- ▶ Carry out action steps according to the illustration.

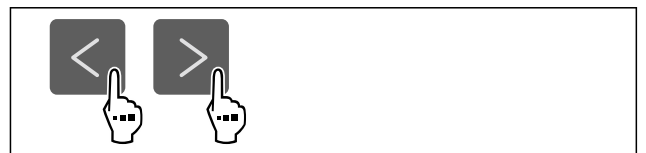

Fig. 161

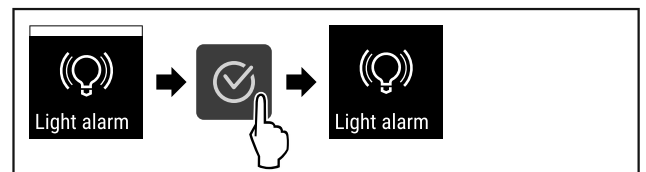

Fig. 162

- ▶ Carry out action steps according to the illustration.
- ▶ The light alarm is deactivated.

7.2.24 Alarm simulation



This function enables you to simulate a temperature alarm in the appliance, e.g. to check whether one of the safety devices triggers correctly. The safety device is connected to the potential-free alarm output. (see 8.3 Interfaces)

Starting the alarm simulation

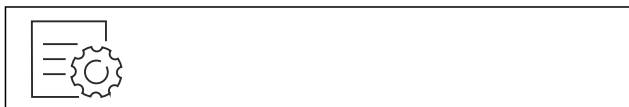

Fig. 163

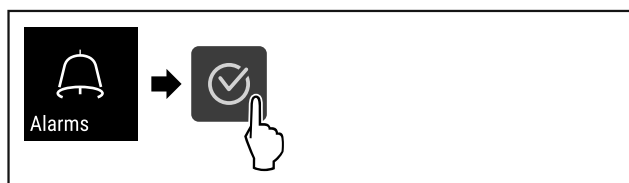

Fig. 164

► Carry out action steps according to the illustration.

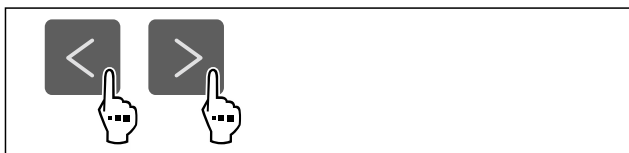

Fig. 165

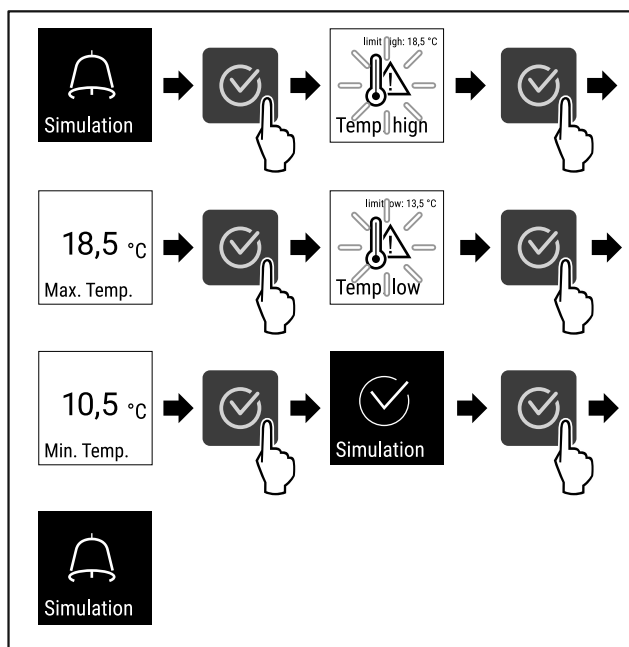

Fig. 166

► Carry out action steps according to the illustration.
 ► The simulation has been performed.
 ► Connected safety devices should have triggered.

7.2.25 Alarm forwarding



This function enables you to set to have one or several alarms to be forwarded to an external alarm receiver. Here, the alarm receiver is connected to the appliance's potential-free alarm output. (see 8.3 Interfaces)

You can select from the following settings:

- Alarm type:
 - Door alarm
 - Temperature alarm
 - Door alarm and temperature alarm
 - All
- Confirm:
 - **Yes:** The alarm is confirmed on the appliance and the externally connected receiver.
 - **No:** The alarm is confirmed on the appliance and remains active on the receiver until the error is remedied.
- Update (only visible if you have selected “Yes” when you confirmed):
 - **Yes:** Alarm repeats.
 - Temperature alarm** depending on the set time (see 7.2.21 Temperature alarm)
 (If you set the delay time of the alarm to “0”, there will be no alarm repetition at the alarm relay either.)
 - Door alarm** after 1 or 4 minutes* (see 7.2.22 Door alarm)
 - **No:** Alarm permanently confirmed.

Activating alarm forwarding

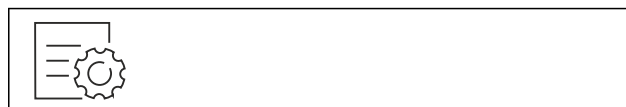

Fig. 167

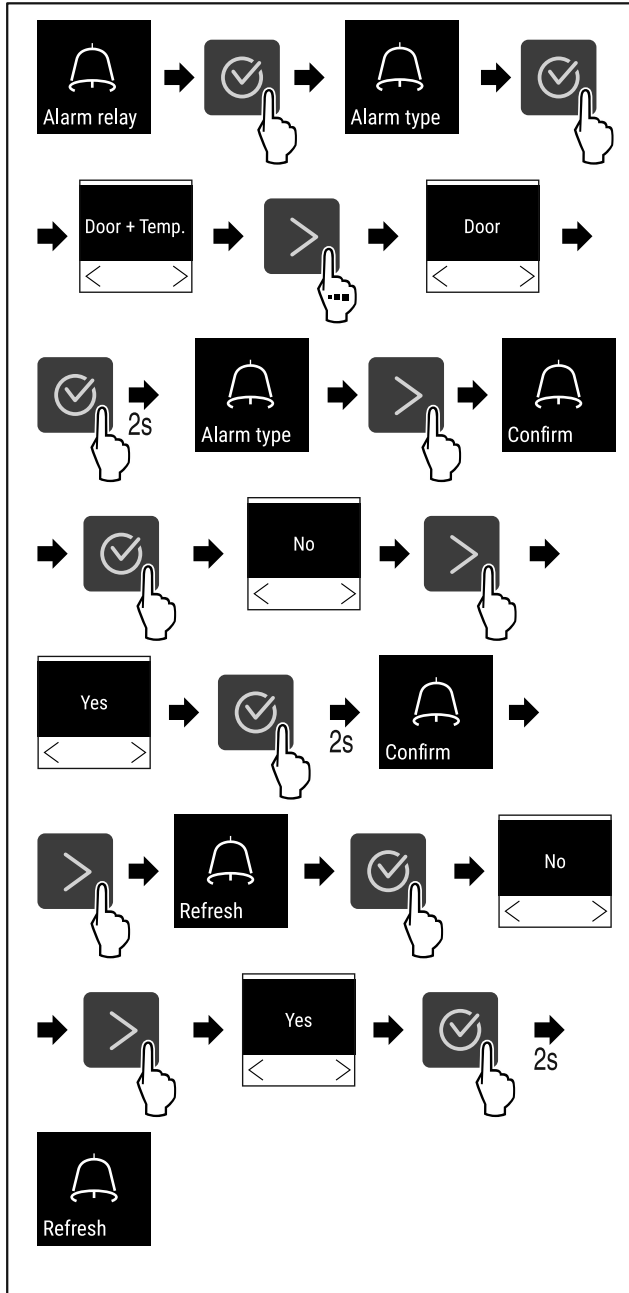

Fig. 168

- ▶ Carry out action steps according to the illustration.
- ▶ Alarm forwarding is set.



7.2.26 Demo mode

Demo mode is a special feature for dealers who want to demonstrate appliance features. If you activate demo mode, all refrigeration functions are deactivated.

If you switch on your appliance and a “D” appears on the status display, demo mode is already activated.

If you activate and then deactivate demo mode, the appliance will be reset to factory defaults. (see 7.2.27 Resetting to factory settings)

Activating demo mode



Fig. 169

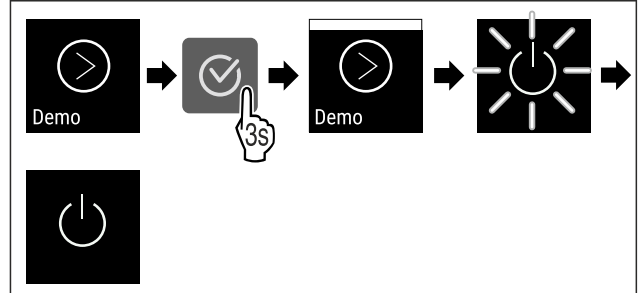

Fig. 170

- ▶ Carry out action steps according to the illustration.
- ▶ Demo mode is activated.
- ▶ Appliance is switched off.
- ▶ Switch on the appliance. (see 5.1 Switching on the appliance (first use))
- ▶ “D” appears in the status display.

Deactivating demo mode



Fig. 171

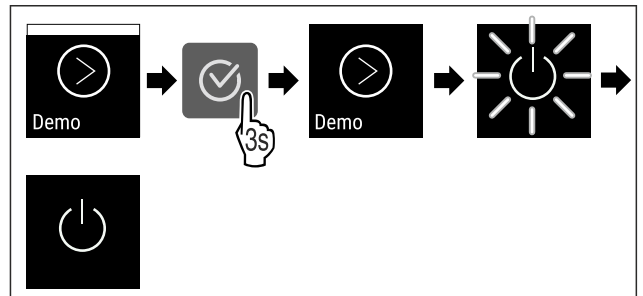

Fig. 172

- ▶ Carry out action steps according to the illustration.
- ▶ Demo mode is deactivated.
- ▶ Appliance is switched off.
- ▶ Switch on the appliance. (see 5.1 Switching on the appliance (first use))
- ▶ Appliance is reset to factory settings.



7.2.27 Resetting to factory settings

Use this function to reset all settings to factory settings. All settings you have made so far are reset to their original settings.

Performing a reset



Fig. 173

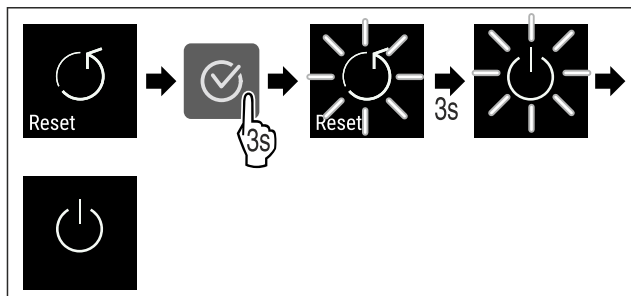

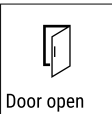

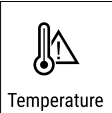

Fig. 174

- ▶ Carry out action steps according to the illustration.
- ▶ Appliance is reset.
- ▶ Appliance is switched off.
- ▶ Restart the appliance. (see 5.1 Switching on the appliance (first use))











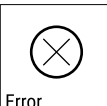

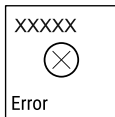

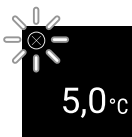
7.3 Messages

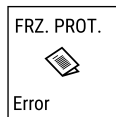

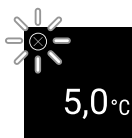



7.3.1 Warnings

Warnings are issued by means of an audio signal and visually via a symbol on the display. The signal gets louder until the warning is acknowledged.

Message	Cause	Remedy
 <p>Door open</p> <p>Door open</p>	<p>The message appears if the door is open for too long.</p>	<p>Close the door. Press the confirmation button. Alarm is ended.</p>  <p>Note You can set how long it takes for this message to appear (see 7.2.22 Door alarm).</p>
 <p>Temperature</p> <p>Temperature alarm</p>	<p>This message appears if the temperature does not match the set temperature. Reasons for the differences in temperature can be:</p> <ul style="list-style-type: none"> - Warm items for refrigeration have been placed inside. - Too much warm room air flowed in when rearranging and removing refrigerated products. - The power was cut off for a prolonged period. 	<p>Press the confirmation button. The warmest temperature is displayed.</p>  <p>Press the confirmation button. The current temperature flashes and the display alternates with the temperature alarm symbol until the set temperature is reached. Check the quality of the chilled goods.</p> 

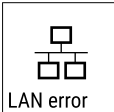

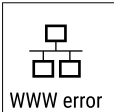

Use

Message	Cause	Remedy
 <p>Error</p> <p>Error</p>	<p>The appliance is defective, there is an appliance error or an appliance module indicates an error.</p>	<p>Relocate the chilled goods. Press the confirmation button. Error code is displayed.</p>   <p>Press the confirmation button. If present, another error code is displayed.</p>  <p>or</p> <p>Status screen with flashing error symbol is displayed. Pressing the navigation buttons displays error code(s) again.</p>  <p>5,0°C</p> <p>Note error code(s) and contact customer service.</p>
	<p>Message indicates that the freezer protection mode is active (e.g. due to frequent door openings or loading with goods).</p>	<p>Press the confirmation button. FRZ.PROT is displayed.</p>   <p>Press the confirmation button. Status screen with flashing error symbol is displayed</p>   <p>5,0°C</p> <p>Pressing the navigation buttons displays error code again.</p> <p>The appliance automatically switches to normal operating mode after a few hours and the message disappears. If the message is displayed repeatedly and the causes listed do not apply, contact customer service. (see 10.3 Customer Service)</p>
 <p>Power</p> <p>Power failure</p>	<p>The message appears after an interruption in the power supply if the temperature is above the alarm limit when the power returns.</p>	<p>Press the confirmation button. The warmest temperature is displayed.</p>  <p>Press the confirmation button. Alarm is ended and the current temperature is displayed. Check the quality of the chilled goods.</p> 
 <p>WiFi error</p> <p>WLAN error</p>	<p>WLAN connection is interrupted.</p>	<p>Check the connection. Press the confirmation button. Alarm is ended.</p> 

Message	Cause	Remedy
 <p>WWW error</p> <p>WLAN WWW error</p>	The message appears if there is no Internet connection via WLAN.	Check the connection. Press the confirmation button. Alarm is ended. 
 <p>LAN error</p> <p>LAN error</p>	LAN connection is interrupted.	Check the connection and network cable. Press the confirmation button. Alarm is ended. 
 <p>WWW error</p> <p>LAN WWW error</p>	The message appears if there is no Internet connection via LAN.	Check the connection. Press the confirmation button. Alarm is ended. 

7.3.2 Reminders

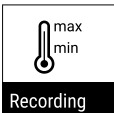
Reminders appear when you are prompted to take action. They are issued by means of an audio signal and visually via a symbol on the display. Acknowledge the message by pressing the confirmation button.

Message	Cause	Remedy
 <p>Maintenance</p> <p>Maintenance reminder</p>	The message appears when the timer for the set maintenance interval has expired.	 <p>Press the confirmation button. Alarm is ended.</p> <p>Note The maintenance interval can be set (see 7.2.8 Maintenance interval reminder).</p>
 <p>Recording</p> <p>Logging reminder</p>	This message appears when the temperature logging memory (999 hours) is full.	 <p>Press the confirmation button. Alarm is ended. The oldest data is overwritten.</p> <p>Note The temperature logging can be reset (see 7.2.4 Temperature recording).</p>

8 Equipment

8.1 Safety lock

The lock in the appliance door is equipped with a safety mechanism.

Equipment

8.1.1 Locking appliance

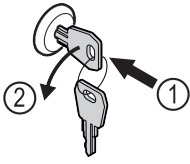

Fig. 175 Example illustration

- ▶ Insert key.
- ▶ Turn key anticlockwise by 90°.
- ▶ The appliance is locked.

8.1.2 Unlocking appliance

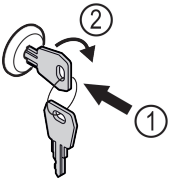

Fig. 176 Example illustration

- ▶ Insert key Fig. 176 (1).
- ▶ Turn key clockwise by 90° Fig. 176 (2).
- ▶ The appliance is unlocked.

8.2 Sensors

The appliance can be equipped with the following sensors for temperature monitoring:

- Safety thermostat sensor
- C sensor

8.2.1 Safety thermostat sensor

The safety thermostat sensor monitors the temperature drop and thus protects against excessively low temperatures (Freeze Protect). If the temperature drops below the threshold value, the appliance regulates the temperature automatically. The error message FRZ. PROT (Freeze Protect) (see 7.3 Messages) appears.

Note

Do not cover the safety thermostat sensor.

8.2.2 C sensor (control sensor)

The C sensor is permanently installed and regulates the interior temperature of the appliance. You can calibrate the C sensor if necessary. (see 7.2.20 Sensor calibration)

8.3 Interfaces

There are various connection options on the back of the appliance.

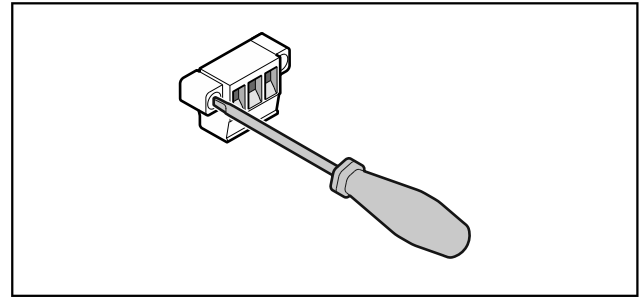

Fig. 177

Note

Screws secure the plugs. To enable disconnection of the plugs, loosen the screws on the left and right.

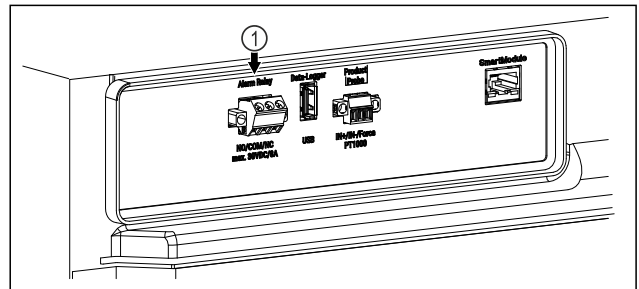

Fig. 178

- (1) Potential-free alarm output

8.3.1 Potential-free alarm output



WARNING

Risk of injury due to electric shock!

- ▶ The appliance may only be connected to an external alarm device by trained specialist personnel.

These three contacts can be used to connect a visual or an acoustic alarm device. The connection is designed for a maximum of **30 V (DC) - 8 A** from a safety low voltage source SELV (**minimum current 150 mA**).

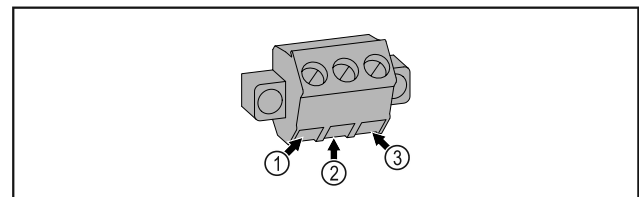

Fig. 179

- (1) NO (normally open)
Connection for indicator lamp, which is active in normal operation or when the appliance is switched off.
- (3) NC (normally closed)
Connection for alarm lamp or audible alarms, which is active when an alarm is triggered or lack of power supply.

(2) COM (common)
External voltage
source

Note

A maintenance reminder function can be activated.
(see 7.2.8 Maintenance interval reminder)

9 Maintenance

9.1 Maintenance schedule

Maintenance work is to be performed at regular intervals to ensure proper appliance function.

Note

We recommend creating a maintenance log in which all work (repairs, checks) performed is documented.

Note

Liebherr recommends yearly maintenance. For an individual offer, please contact Customer Service (see 10.3 Customer Service) .



CAUTION

Danger of injury and damage due to unprofessional maintenance work!

Personal injury and material damage.

- ▶ Maintenance work may only be performed by trained specialist personnel.



WARNING

Short-circuit hazard due to live parts!

Electric shock or damage to the electronics.

- ▶ **Switch off the appliance.**

- ▶ Pull out mains plug or switch off fuse.

Component	Activity	Maintenance interval
Sheet metal parts	Check for damage and corrosion. Replace damaged parts: (see 10.3 Customer Service)	Yearly
Door, hinges	Check alignment (see 3.6 Aligning the door) , ease of movement, and tight fit.	Yearly
Lock, door handle *	Check for ease of movement and tight fit.	Yearly
Door seal	Check for damage, wear, and tight fit. A replacement door gasket is available via Customer Service (see 10.3 Customer Service) .	Yearly
Sensor	Calibrate sensor. (see 7.2.20 Sensor calibration)	Yearly
Sensor feedthrough	Check that the sealing compound is intact.	Yearly
Surfaces	Cleaning (see 9.3 Cleaning the appliance)	Recommendation: monthly or as required/specified at installation location

Maintenance

Component	Activity	Maintenance interval
Surfaces	<p>Disinfection</p> <p>Liebherr has tested the following disinfectants: Dismozon pur 1 % Lösung (Bode Chemie), Suma Quicksan (Diversey), Incidin Extra N (Ecolab Healthcare), Acrylan (Antiseptica chem.-pharm. Produkte), Buraton 10 F (Schülke und Mayr), Frankocid N (Franken Chemie), Apesin DSR 50 (Tana), Nüscosept Spray (Dr. Nüsken), Melsept SF (B. Braun Melsungen), Kohrsolin (Bode Chemie), Neoquat S (Dr. Weigert), Indicin Rapid (Ecolab Healthcare), Bacillocid Spezial (Bode Chemie), Neoform K Spray (Dr. Weigert), Apesin Desinf. Spray (Tana), Nüscosept 100 (Dr. Nüsken), Antisept T (Fink Tec), Apesin AP 100 0,50% Lösung (Tana), Perform Pulver 2% Lösung (Schülke und Mayr)</p> <p>Observe the operating instructions of the respective manufacturer. If disinfectants other than those stated are used, test them on a less exposed area first.</p>	Recommendation: monthly or as required/specified at installation location
Installation location, appliance	<p>Decontamination</p> <p>The appliance is suitable for room decontamination with hydrogen peroxide H₂O₂.</p> <p>In this context, the values of the following application specifications must not be exceeded: Concentration: maximum 250 ppm. Humidity: maximum 85%. Maximum permissible room temperature as per climate class. (see 2.4 Range of appliance use)</p>	Recommendation: as required/specified at installation location, maximum 2x per year
Fan air slots	Cleaning	Yearly
Alarm relay	Check plug connections for tight fit.	Yearly
Network cable	Check for damage.	Annually or when changing the location
Adjustable feet / rollers	<p>Check the functional capability, for damage and a tight fit.</p> <p>Replace any damaged parts. (see 10.3 Customer Service)</p>	Annually

9.2 Defrosting the appliance



WARNING

Appliance incorrectly defrosted!
Injuries and damage.

- ▶ Do not use mechanical devices or other means to accelerate the defrosting process, other than those recommended by the manufacturer.
- ▶ Do not use any electrical heating or steam cleaning equipment, naked flames or defrosting sprays.
- ▶ Do not remove ice with sharp objects.

Defrosting is performed automatically. The water from the defrosting process runs out via the drain opening and is evaporated.

To maintain the functionality of the appliance, we recommend defrosting it when there is a high buildup of ice. Icing in the interior is determined by the location (e.g. high humidity), settings on the appliance and incorrect user behavior.

If the automatic defrost cycle is not sufficient:

- ▶ Start the automatic defrost manually. (see 7.2.19 Defrosting)

If the problem persists, defrost the appliance manually:

- ▶ Switch off appliance. (see 7.2.2 Switching appliance on and off)
- ▶ Disconnect power plug.
- ▶ Store refrigerated items elsewhere.
- ▶ Leave the appliance door open during defrosting process.
- ▶ Soak up remaining defrost water with a cloth, clean the drain opening and the appliance.

9.3 Cleaning the appliance

9.3.1 Preparing



WARNING

Short-circuit hazard due to live parts!
Electric shock or damage to the electronics.

- ▶ **Switch off the appliance.**
- ▶ Pull out mains plug or switch off fuse.



WARNING

Danger of fire

- ▶ Do not damage the refrigerant circuit.

- ▶ Empty the appliance.
- ▶ Pull out the power plug.
- ▶ Observe the notes on appliance transport.

9.3.2 Cleaning the housing

NOTICE

Improper cleaning!
Damage to the appliance.

- ▶ Only use soft cleaning cloths and ph-neutral all-purpose cleaners.
- ▶ Do not use steel wool or sponges that scour or scratch.
- ▶ Do not use caustic or abrasive cleaning materials or those containing sand, chloride, or acids.



WARNING

Risk of injury or damage due to hot steam.
Hot steam can cause scalding/burns and damage to surfaces.

- ▶ Do not use steam cleaners.

NOTICE

Risk of damage due to short circuit.

- ▶ When cleaning the appliance, make sure no water gets into the electrical components.
- ▶ Wipe the housing down with soft, clean cloth. If very dirty, use lukewarm water with a neutral cleaner. Glass surfaces can also be cleaned with glass cleaner.
- ▶ Clean the condenser coil every year. If the condenser coil is not cleaned, this significantly reduces the efficiency of the appliance.

9.3.3 Cleaning the interior



WARNING

Short-circuit hazard due to live parts!
Electric shock or damage to the electronics.

- ▶ **Switch off the appliance.**
- ▶ Pull out mains plug or switch off fuse.



WARNING

Risk of injury or damage due to hot steam.
Hot steam can cause scalding/burns and damage to surfaces.

- ▶ Do not use steam cleaners.

NOTICE

Improper cleaning!
Damage to the appliance.

- ▶ Only use soft cleaning cloths and ph-neutral all-purpose cleaners.
- ▶ Do not use steel wool or sponges that scour or scratch.
- ▶ Do not use caustic or abrasive cleaning materials or those containing sand, chloride, or acids.

Note

- ▶ Defrost water drain (see 2.2 Overview of appliances and equipment) : Remove deposits using a thin object (e.g. a cotton bud).

Note

Do not damage or remove the type plate on the inside of the appliance. The type plate is important for Customer Service. (see 10.3 Customer Service)

- ▶ Open the door.
- ▶ Empty the appliance.
- ▶ Clean the interior and equipment parts with lukewarm water and a little dish detergent. Do not use any gritty or acidic cleaning agent or any chemical solvent.

9.3.4 After cleaning

- ▶ Wipe the appliance and equipment parts dry.
- ▶ Connect and switch on appliance.
When the temperature is sufficiently cold:
- ▶ Place in items for refrigeration.
- ▶ Clean regularly.
- ▶ Clean the refrigeration machine with heat exchanger and remove dust from it once a year.

Customer support

10 Customer support

10.1 Technical data

Temperature range	
Cooling	+3 °C (38 °F) to +16 °C (60 °F)

Maximum load per shelf ^{A)}			
Appliance width	550 mm (21 5/8 in)	600 mm (23 1/2 in)	750 mm (29 7/16 in)
Grid shelves	--	45 kg (99.21 lb)	60 kg (132 lb)
Glass shelf	40 kg (88.18 lb)	40 kg (88.18 lb)	40 kg (88.18 lb)
Drawer (freezers)	15 kg (33.07 lb)	15 kg (33.07 lb)	15 kg (33.07 lb)

A) Heavier loads may result in a slight bending of the shelves.

Maximum total load and net weight		
Model (see 3.2 Appliance dimensions)	Maximum total load	Net weight
SRTvg 1501	180 kg (397 lb)	35 kg (77.16 lb)
SRTvg 1511		43 kg (94.80 lb)

Net capacity
See net capacity on the type plate. (see 2.2 Overview of appliances and equipment)

Lighting*	
Energy efficiency class ^{A)} *	Light sources*
This product contains one or more energy efficiency class G light sources	LED

A) The appliance may contain light sources with different energy efficiency classes. The lowest energy efficiency class is indicated.

Defect	Cause	Remedy
The appliance is not working.	The appliance is not switched on.	► Switch on the appliance.
	The power plug is not properly inserted in the socket.	► Check the power plug.
	There is a problem with the wall socket breaker.	► Check the breaker.
	Power failure	► Keep the appliance closed.

WLAN frequency specification	
Frequency band	2.4 GHz
Maximum radiated power	<100 mW
Purpose of the wireless equipment	Integration in the local WiFi network for data communication

Setup conditions	
Degrees of pollution (surrounding the appliance)	PD2
Ambient temperature	+10 °C (50 °F) to +35 °C (95 °F)
Maximum relative ambient moisture	75%, not condensing
Maximum operating elevation (meters above sea level)	2000 m (6,561.68 ft) 1500 m (4,921.26 ft) (glass door)*

Electrical values	
Nominal voltage	115-127 V ~
Frequency	60 Hz
Connected load	2,0 A
Maximum power supply fluctuation	+/-10%
Overvoltage categories	II

10.2 Technical malfunction

Your appliance is designed and built to ensure it works reliably and has a long service life. If a malfunction nonetheless occurs during operation, please check whether the malfunction is due to an operating error. If this is the case, you will be charged for the cost incurred even if this falls within the warranty period.

You can rectify the following malfunctions yourself.

10.2.1 Appliance function

Defect	Cause	Remedy
		▶ If necessary move the refrigerated/frozen items to another fridge or freezer if the power is off for a prolonged period.
	The IEC socket is not correctly plugged into the appliance.	▶ Check the IEC socket.
The temperature is not cold enough.	The appliance door is not closed properly.	▶ Close the appliance door.
	Ventilation is not sufficient.	▶ Unclog the ventilation grill and clean it.
	The ambient temperature is too high.	▶ Observe the suitable ambient conditions: (see 2.4 Range of appliance use)
	The appliance was opened too many times or for too long.	▶ Wait to see if the required temperature corrects itself. If not, contact Customer Service. (see 10.3 Customer Service)
	The temperature is set incorrectly.	▶ Set a colder temperature and check after 24 hours.
	The appliance is too close to a heat source (stove, heater etc).	▶ Move either the appliance or the heat source.

10.3 Customer Service

First check whether you can remedy the fault yourself. If this is not the case, please contact Customer Service.

You can find the address in the enclosed brochure "Liebherr-Service" or at home.liebherr.com/service.



WARNING

Unprofessional repair!
Injuries.

- ▶ A damaged power cable may only be replaced by the manufacturer, the manufacturer's Customer Service or a similarly qualified person.
- ▶ For appliances with plug and play connection cables, the change can be made by the customer.

10.3.1 Contacting Customer Service

Make sure you have the following appliance information ready:

- Appliance name (model and index)
- Service no. (service)
- Serial no. (S no.)
- ▶ Access the appliance information via the display (see 7.2.16 Appliance information).
- or-
- ▶ Refer to the type plate for appliance information. (see 10.4 Type plate)
- ▶ Note appliance information.
- ▶ Inform Customer Service: Report faults and the appliance information.
- ▶ This will help us to provide fast and focused service.

- ▶ Follow any further instructions provided by Customer Service.

10.4 Type plate

The type plate is inside the appliance. See appliance overview.

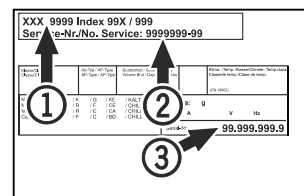

Fig. 180

- (1)** Appliance designation
- (2)** Service No.
- (3)** Serial No.

11 Shutting down

- ▶ Empty the appliance.
- ▶ Switch off appliance.
- ▶ Pull the power plug from the outlet.
- ▶ If necessary, remove the IEC socket: Pull the IEC socket out of the appliance plug while turning it to the left and right at the same time.
- ▶ Clean the appliance. (see 9.3 Cleaning the appliance)
- ▶ If available: Remove the covers and insulation of the sensor feed-through to prevent mold from forming.
- ▶ Leave the door open so that no bad odors form.

Disposal

Note

Damage to the appliance and malfunctions!

- ▶ After shutting down, only store the appliance at the permitted room temperature of between -10 °C (14 °F) and +50 °C (122 °F).

12 Disposal

12.1 Preparing the appliance for disposal



WARNING

Risk of child entrapment!

Before you throw away your old refrigerator or freezer:

- ▶ Take off the doors.
- ▶ Leave the shelves in place so that children may not easily climb inside.



Li-Ion

Liebherr uses batteries in some of its appliances. You should remove these before disposal of the old appliance for environmental reasons. If your appliance contains batteries, a corresponding notice is attached to the appliance.

Lamps If you can remove the lamps yourself without destroying them, also remove these before disposal.

- ▶ Take the appliance out of operation.
- ▶ If possible: Remove lamps without destroying them.

12.2 Disposing of the appliance in an environmentally friendly manner



The appliance still contains valuable materials and must be collected separately from unsorted municipal waste so it can be recycled.



Li-Ion



Li-Ion

Dispose of batteries separately from the old appliance. Certain batteries should NOT go in household garbage or recycling bins. Waste batteries can always be recycled or taken to household hazardous waste collection points. To prevent fires from lithium-ion batteries, tape battery terminals and/or place batteries in separate plastic bags and never put these batteries in household garbage or recycling bins.

Lamps

Dispose of removed lamps via the respective collection systems.

For USA:

Check the Responsible Appliance Disposal (RAD) program to find a RAD partner near you.

For Canada:

Follow your local guidance about recycling and disposal capabilities near you.



WARNING

Leaking refrigerant and oil!

Fire. The refrigerant contained within the appliance is environmentally friendly, but flammable. The oil contained within the appliance is flammable. Escaping refrigerant and oil can ignite if they are of high enough concentration and are exposed to an external heat source.

- ▶ Do not damage the pipelines of the coolant circuit and the compressor.

- ▶ Observe the notes on appliance transport.
- ▶ Transport the appliance away without damaging it.
- ▶ Dispose of batteries, lamps, and the appliance according to the above specifications.

13 Additional information

Further information on warranty conditions can be found in the enclosed service brochure or on the Internet at <https://home.liebherr.com>.



Reference in the event of an appliance fault:

Model ID / Inventory number:

Quick Start Guide for everyday use

Information about using this Quick Start Guide:

- This Quick Start Guide is not a substitute for the full operating instructions nor is it a substitute for appliance training.
- This Quick Start Guide provides support for everyday use and handling the appliance.
- Read the full operating instructions and the safety instructions contained therein.

This quick start guide is for: SRTvg 15..



Using the QR code, you can read the full operating instructions.



Intended use

Foreseeable incorrect use

Do not use the appliance for the following applications:

- Storage and cooling of:
 - Chemically unstable, flammable or corrosive substances
 - Blood, plasma or other body fluids for the purpose of infusion, application or introduction in the human body
- Use in areas with risk of explosion
- Outdoor use or in areas where it is exposed to splash water or damp conditions

When stocking, observe the following points:

- Position grid shelves according to the height required.
- Observe maximum load.
- When the storage temperature has been reached, load the appliance (compliance with cold chain).
- Keep the ventilation slots of the recirculation fan free in the interior.
- Items for refrigeration must not come into contact with the evaporator on the rear wall.
- Keep liquids in closed containers.
- Leave space when storing items for refrigeration to ensure adequate air circulation.

Status display



Fig. 181 Status display with actual temperature

Displaying temperature recording

The temperature recording displays the length of the recording and the minimum and maximum temperatures measured during this period of time.



Fig. 182

Resetting temperature recording

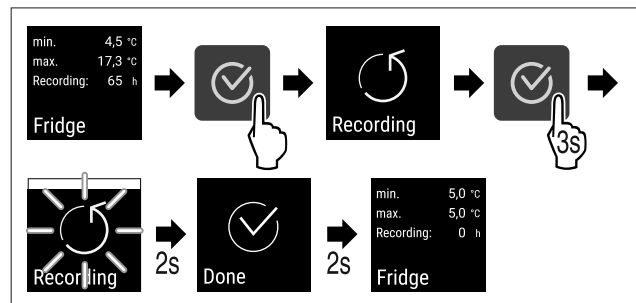

Fig. 183

Unlocking appliance

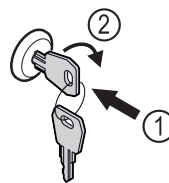

Fig. 184

- ▶ Insert the key. Fig. 184 (1)
- ▶ Turn the key clockwise by 90°. Fig. 184 (2)
- ▶ The appliance is unlocked.

Quick Start Guide for everyday use

Locking appliance

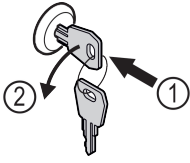

Fig. 185

- ▶ Insert the key. Fig. 185 (1)
- ▶ Turn the key anticlockwise by 90°. Fig. 185 (2)
- ▶ The appliance is locked.

Cleaning appliance

- ▶ Empty the appliance.
- ▶ Pull out the power plug.
- ▶ Observe the information in the operating instructions.
- ▶ Dry the appliance and equipment thoroughly after cleaning.
- ▶ Connect the appliance.
- ▶ Switch on the appliance.
- ▶ Load the appliance once the storage temperature is reached.



What should I do if there is a fault?

A message appears in the display if there is a fault. Messages have different meanings:

Symbol color in the display	Meaning	Remedy
WHITE with black bar	Reminder Reminder of general procedures. You can carry out these procedures to eliminate the message.	Consult the operating instructions and perform the troubleshooting steps.
WHITE	Warning Appears when there are malfunctions. You can eliminate simple malfunctions yourself.	Consult the operating instructions and perform the troubleshooting steps.
If you cannot remedy the fault yourself, contact a competent member of staff or your nearest customer service outlet.		



home.liebherr.com/fridge-manuals

EN Table-height refrigerator
ORIGINAL OPERATOR'S MANUAL

Issue date: 20260130

Part number index: 7086655-00

For service in the United States and Canada: Liebherr Service Center
Toll Free: 1-844-542-6782
Email: service-commercial.us@liebherr.com
PlusOne Solutions, Inc.
3501 Quadrangle Blvd, Suite 120
Orlando, FL 32817