

Model 300 Sky Sentry Fume Extractor

Model # SS-300-SKY



The **Model 300 Sky Sentry Fume Extractor** mounts on a wall to provide source capture fume extraction while freeing up valuable bench top and floor space in limited space environments. This system features a free-hanging, self-supportive and flame-retardant flex arm with easy mobility to allow the operator to maneuver the arm to their desired location. When mounted to the wall, the arm supports a 180° swivel radius and a 62.5" horizontal span.

Typical applications for this system include: *welding fume extraction, solder fume control, brazing, particulate, removal of organic vapors, solvent and epoxy fumes, chemical fumes, light grinding, and various other industrial processes that require wall-mounted fume extraction.*

Depending on the application, the **Model 300 Sky Sentry Fume Extractor** can utilize several filter combinations. Typical filtration media include: **HEPA filter** (up to 99.97% efficiency on particles 0.3 microns and larger), **ASHRAE filter** (up to 95% efficiency on particles 0.5 microns and larger), **Activated Carbon**, and **specialty-blended filtration media** (i.e. acid gas, mercury, aldehyde, and ammonia).

The **Model 300 Sky Sentry Fume Extractor** combines quiet operation, energy-efficient technology, and a unique mounting option that creates an effective solution for many applications that require fume and particulate removal. *Sentry Air Systems offers a smaller model [SS-200-SKY] and larger model [SS-400-SKY].*

Product Features

- **Includes:** variable speed controller (115V only), ON/OFF toggle switch (220V only), and wall mounting brackets.
- **Optional:** Magnehelic Gauge and hour counter
- Quiet operation
- Reliable, low maintenance operation
- Low power consumption
- Simple, quick "no tool" filter change
- Long filter life



Model 300 Sky Sentry Fume Extractor



Model 300 Sky Sentry mounts on wall to free up needed benchtop space.



21221 FM 529 Rd, Cypress, TX 77433
1.800.799.4609 • sales@sentryair.com

www.sentryair.com

Fume & Particulate Removal

Product Specifications

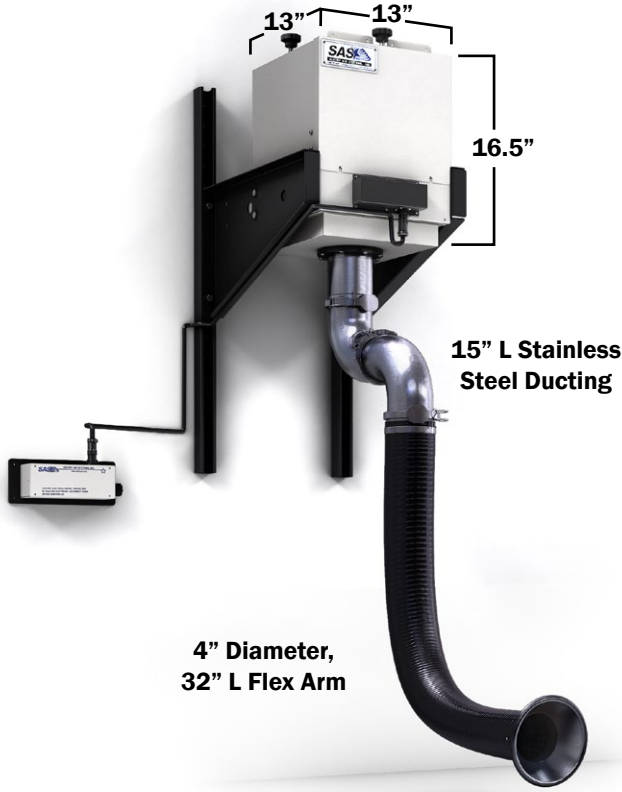

4" Diameter,
32" L Flex Arm

15" L Stainless
Steel Ducting

Dimensions are approximate



21221 FM 529 Rd
Cypress, TX 77433
1.800.799.4609
sales@sentryair.com

www.sentryair.com

Base Unit Dimensions	Length: 13" Width: 13" (Not including mounting brackets) Height: 16.5"
Arm Dimensions	4" diameter x 32" long flex arm with 15" long stainless steel ducting 7" round capture hood
Cabinet Material	16 ga. carbon steel with polyester coating on all surfaces
Weight (approximately)	60 - 70 lbs
Air Volume (approximately)	Up to 350 CFM
Electrical	115/1/60, 2 amps 220/1/50, 0.75 amps 8' grounded power cord with NEMA 5-15P plug
Sound Level	Approx. 61 to 66 dba (Blower speed: Low to High)
Main Filter Options	<i>Depending on the Application:</i> HEPA [up to 99.97% efficiency on particles 0.3 microns and larger] ASHRAE [up to 95% efficiency on particles 0.5 microns and larger] Activated Carbon Specialty-Blended Filter Media [i.e. Acid Gas, Mercury, Aldehyde, Ammonia]
Warranty	Limited two-year warranty from date of shipment on defects due to materials or workmanship.
US Patent	#5,843,197 Pending