

*Organomation*TM

Laboratory Evaporators and Extractors

S-EVAPTM

Solvent Evaporation System

Instruction Manual



For Models: 12060, 12090, and 12008 (all configurations)

Your Partners In Sample Preparation since 1959

978.838.7300 • organomation.com

Introduction

Instrument Items Shipped	4
Instrument Description	7
Glassware sets	5

Installation

Location	8
Bath Setup	8
Instrument Setup	13

Safety Considerations - Read before operation 18**Operation**

Instrument Control Identification	17
Planning and Preparation	19
Type Z Purge Positive Pressure Bath Option	9
Bath Operation	20
Instrument Operation	25
Optimization	23

Maintenance and Cleaning 26**Trouble Shooting** 28**Technical Information**

Service and Returns	29
Shipping - Claims for damage or shortage	30
Specifications	31
Wiring Diagrams	32

Contacting Organomation and its Representatives 29

Items Shipped

Carefully check the contents of all cartons received for damage which may have occurred in transit. Retain all cartons and packaging materials until all components have been checked against the packing slip, the component list below, and the equipment has been assembled and tested. Contact Organomation Associates Inc. immediately if any damage or discrepancies are found.

Your shipment should contain one or more of the instruments and / or glass sets shown below. Option codes are listed on the next page.

Cat #	Instruments Only (Glassware Sold Separately)
12060	8 Position S-EVAP, 4.5" deep x 12" Diameter Bath - 250 ML RB Flasks
12090	10 Position S-EVAP, 4.5" deep x 16" Diameter Bath - 250 ML RB Flasks
12008	8 Position S-EVAP, 4.5" deep x 16" Diameter Bath - 500 ML RB Flasks

Flow meter Assembly with Mounting Bracket & Tubing.

P2121 0-3500 CCM for condenser water supply.

B2110 OA-SYS Water Bath 1100W, Model 12060

B2104 OA-HEAT Water Bath 1400W, Models 12090, 12008

NA1110 Thermometer 0 - 100° Celsius, 6" long, 4.5" deep baths (Optional)

---- Water Services Tube Assembly includes:
 SS water inlet Tube 3/8" (mm) OD, PVC water outlet tube 1/2" (12mm) OD,
 and Polypropylene extendable jacket.

V11437 Ball Driver, 5/32" x 9" Long.

---- Manual for all S-EVAP-RB models.

---- SS Cover disk assembly, includes: Hole covers (5 or 8, subject to Model), collar, and tear drop handles, 3.0" hole size for 12" diameter and 3.875" hole size for 16" diameter bath.

Cat #	Glassware Sets - Each Set includes the following:
GS2161	125 ML Glassware Set, includes: <ul style="list-style-type: none">• GP3215 (Quantity 2): Standard flat bottom flask 125 ml, for 24/40 joint• GP2212: Hopkins condenser 375mm with side arm for individual collection flask, for 24/40 joint• GA2273: Glassware clip for 24/40 joint
GS2162	250 ML Glassware Set, includes: <ul style="list-style-type: none">• GP3216 (Quantity 2): Standard flat bottom flask 250ml, for 24/40 joint• GP2212: Hopkins condenser 375mm with side arm for individual collection flask, for 24/40 joint• GA2273: Glassware clip for 24/40 joint
GS2163	500 ML Glassware Set, includes: <ul style="list-style-type: none">• GP2214 (Quantity 2): Flat bottom flask 500ml, for 24/40 joint• GP2212: Hopkins condenser 375mm with side arm for individual collection flask, for 24/40 joint• GA2273: Glassware clip for 24/40 joint
XA2284	Adapter Rings, 3.875 inch
XA2286	Allow 250 ml flasks to be used in instruments designed to support 500 ml flasks Adapter Rings, 3.0 inch Allow 125 ml flasks to be used in instruments designed to support 250ml flasks

Option Codes and additional items shipped

The following list contains option codes and items which may have been shipped in conjunction with the standard parts shown on the previous pages. Please check your packing list and order information carefully to determine if these items are included in your shipment.

Your shipment may contain the following optional items:

Option	Description
-N	Nitrogen manifold option, additional parts include: Gas manifold (5, 8 or 10 position subject to Model) with quick disconnect auto shutoff fittings, gas flow meter (0-10 LPM), Corrugated tubing (8 or 10 tubes, subject to model) with red caps, Manifold to flow meter tube, and 1/4" ID x 3/8" OD PVC gas connection line 5 feet long. See specific glass set for additional glass items.
-V	Vacuum manifold (5,8 or 10 position subject to Model) tubing & connectors
-Z	OA-SYS water bath has been modified for the Type-Z Purge Positive Pressure bath option. Additional parts include: differential pressure gauge, mounting bracket, and tubing.
-2	OA-SYS water bath is wired as a 240 Volt unit.

Instrument Description

The S-EVAP-RB Solvent Evaporation System is designed for general evaporation and / or concentration of analytical or environmental samples in a variety of glassware configurations to meet the needs of specific methods under controlled and reproducible conditions.

The S-EVAP-RB system features rapid solvent evaporation with solvent vapor recovery. Solvent recoveries can exceed 96% by volume under ideal conditions. The system may be used with cold tap water or a recirculating chiller system. The digital controlled water bath provides even uniform heating without scalding final samples. The parallel water manifold system provides even cooling water to each of the condensers. The rotary water manifold allows unlimited instrument rotation for front loading without condenser tubing wrapping about the instrument.



Figure 1

Location

The S-EVAP-RB evaporator system should be located on a bench top or in a chemical fume hood if hazardous or flammable materials and solvents are to be used. The location should provide the necessary support services for the instrument. These include electrical power (required for water bath), cold water, and drain. Please review the Specifications Section for further information.

Bath Setup

1. Position the bath on a stable flat surface such as a lab bench or in a chemical fume hood.
2. Turn the bath rocker switch to the “OFF” position.
3. Turn the heat switch to the center “OFF” position.
4. Plug the bath electrical cord into a 3 wire grounded electrical outlet rated for 110-120 VAC, 50-60 Hz, single phase, 15 amps.

Optional 220 VAC baths are clearly marked and should be plugged into a three wire grounded electrical outlet rated for 220-240 VAC, 50-60 Hz, single phase, 15 amps.

Bath Setup (Continued)

6. Type-Z Purge Positive Pressure Bath option - **If you do not have this option, please proceed to the next section.** Procedures for operating this system may be found in the Operation Section. Quick start instructions are posted on the front of the bath. Please refer to Figure 2 below for parts list and installation.
 - A. Install the Type Z Purge Gauge Assembly to the rear of the bath as shown. The bracket attaches to the rear of the bath and is held in place by a 6-32 x 1/4" screw on the shoulder spacer and by a 1/4" bulkhead hex nut on the gas inlet fitting.
 - B. Connect the small white silicone tube attached to the gauge to the gas inlet fitting using the compression nut provided.
 - C. Attach the filter with 5 foot tube to the plastic elbow fitting located at the base of the bath or control box. Insert the filter into the fitting and tighten the nut. Connect the tube to a clean gas source.
 - D. Test the system by turning on the gas flow to the Z Purge System. Adjust the gas flow until the gauge reads 0.3 inches water pressure.

WARNING - If this unit is located in a hazardous area where volatile fumes are present, the Z-Purge System must be activated for a minimum of 10 minutes prior to activation of bath power. Please review the Safety and Operations sections.

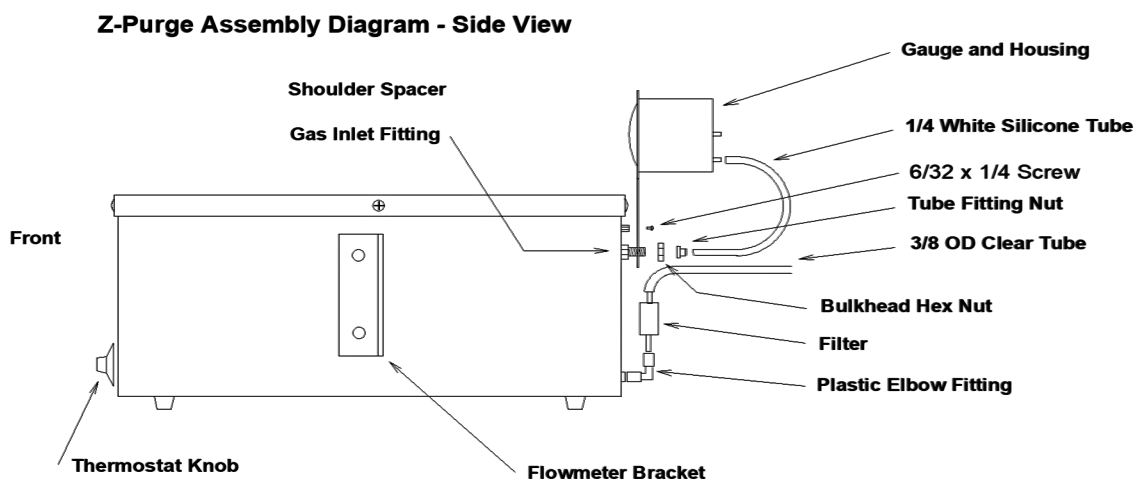

Side mount control box (included on some models) not shown here.

Figure 2

Bath Setup (Continued)

7. Flow meter assembly - Provided with all S-EVAP Systems. If an OA-SYS bath was purchased without an S-EVAP instrument, proceed to the next section.

A. Units without control box

Attach the flow meter to the bracket mounted on the bath with the two 10/32 x 1/2" screws provided. The meter should be positioned with the scale facing forward.

B. Units with control box

Attach the flow meter and bracket assembly onto the left rear corner of the control box with the two 10/32 x 1/2" screws provided. The meter should be positioned with the scale facing forward.

- C: Connect the clear 1/4" ID x 3/8" OD tube to a cold water source (tap or chiller). Source should be capable of producing 3.5 LPM (1 GPM) and being regulated to 30 psig maximum. If the source is in excess of 30 psig, then Organomation part # XA0631 Pressure Reducing Regulator will be required.

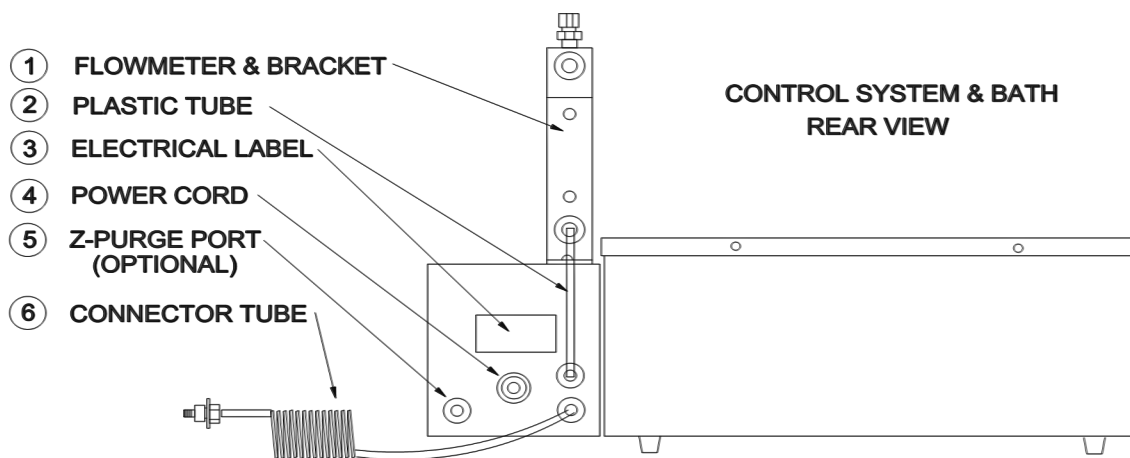
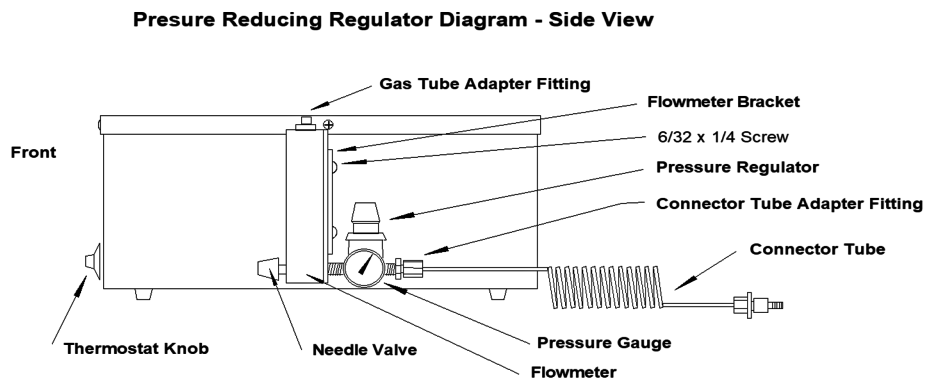

Figure 3

Bath Setup (Continued)

8. **Pressure Reducing Regulator Option - If you do not have this option, proceed to the next section.** When purchased with an S-EVAP System, this item is pre-installed onto the flow meter, between the flow meter and the Connector Tube. Refer to Figure 4.
- A. Remove the flow meter from the bracket.
 - B. Remove the Connector Tube and fitting from the flow meter.
 - C. Connect the Pressure Reducing Regulator to the lower fitting on the back of the flow meter. Position the regulator such that the adjustment knob is straight up and the gauge points away from the bath.
 - D. Connect the Connector Tube to the regulator.
 - E. Re-connect the flow meter to the bracket.
 - F. The regulator may be adjusted by pushing the knob downwards and then rotating the knob. The knob may be locked in position lifting it upwards.

**Figure 4**

WATER SERVICES TUBE ASSEMBLY

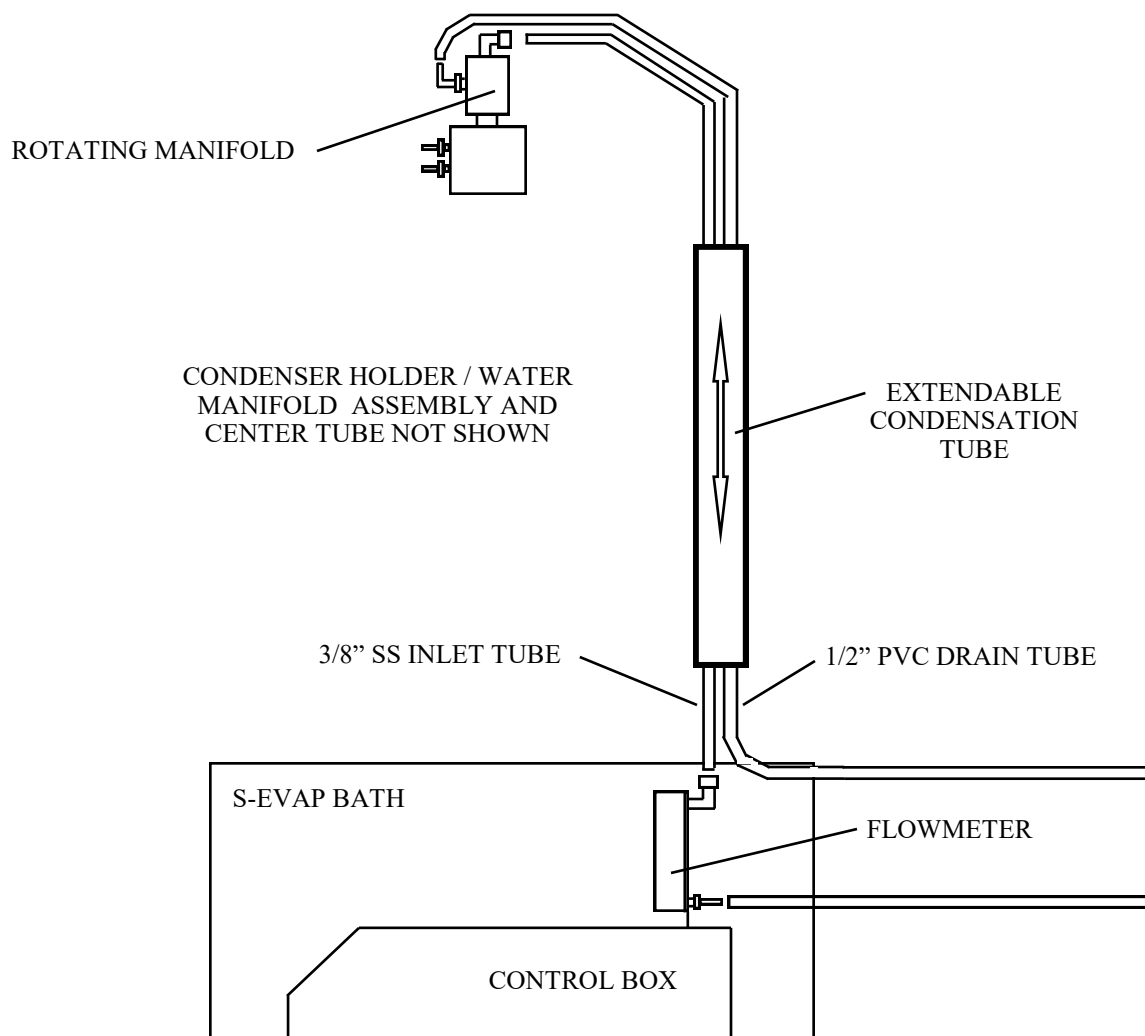

Figure 5

Instrument Setup

1. Place the instrument and stand into the water bath or on a flat level surface. The stand is loose relative to the instrument and must be held in place while placing the assembly into position.
2. Place the cover disk assembly onto the instrument. Slide the disk upwards 5” and secure in place with the set screws in the disk collar.
4. Thermometer Installation – Non control box units only. If your bath has a control box or digital display installed, please go to the next section.

Install the SS Thermometer into the fitting on the cover disk assembly. Tighten the nut to secure in place.

Instrument Setup (Continued)

5. Water services tube assembly
 - A. Connect the top of the water services tube assembly to the elbow fitting located at the top of the instrument.
 - B. Connect the clear 3/8" ID tube at the top of the services tube assembly to the black hose barb located at the top of the instrument. The spiral wrap prevents the drain tube from collapsing at the bend.
 - C. Place the instrument into the water bath if not already installed.
 - D. Connect the lower SS tube of the services tube assembly to the top of the flow meter located on the side of the bath or top of the control box.
 - E. Connect the drain tube at the bottom of the services tube to a suitable drain or chiller system. Chiller systems purchased from Organomation have the proper connection fittings provided, please reference the water chiller instructions for proper chiller connections.
 - F. Once everything is in place and correctly positioned, tighten the SS nuts with a wrench.

6. Cover Disk Adjustment
 - A. Install a single glass condenser into the condenser holder plate assembly located at the top of the instrument.
 - B. Loosen the set screws in the cover disk collar so that the disk may be rotated.
 - C. Rotate the cover disk until the round bottom flask can be placed vertically into position on the cover disk and connect to the condenser. The condenser may be moved upwards in the holder and then lowered onto the flask.
 - D. Push the center tube downwards against the spring at the base of the stand a distance of 6 mm (1/4") and tighten the cover disk collar set screws. When the center tube is released the cover disk should raise slightly. When fully loaded with glassware, this will reduce drag on the bath rim and allow the instrument to rotate more freely.

Instrument Setup (Continued)

7. Remove all glassware from the system, if present.
8. Fill the bath with water

Glassware setup

Note: Glassware manufactured by other sources may not fit or work correctly in the S-EVAP system. Care and caution should be exercised relative to these instructions and in operation of non Organomation glassware in the S-EVAP system.

1. Condenser Glassware Setup Procedures – The following procedures cover setup and installation of Organomation glassware in the S-EVAP instrument.
 - A. Install the white silicone water tubes with quick connect fittings onto the hose barbs on the condensers (two per condenser). When elbow QD's are present, they should face each other when installed.
 - B. Install each condenser in sequence around the condenser holder plate assembly. Condensers may be installed by loading the condenser from the bottom with the water tubes facing outwards. When the upper barb is above the second plate, rotate the condenser 180° so that the water tubes are facing inwards. The condenser may be lowered and released, and will hang securely in the condenser holder.
 - C. Connect the water tubes on each condenser to the manifold. For optimal position, connect each fitting on the water tube to the fitting on the manifold which is three fittings to the left of the closest fitting to the condenser. Each condenser will have one water tube connected to the upper and lower manifold.
2. Connect the 250 or 500 mL round bottom flasks to the condenser side. Secure in place with the green 24/40 joint clip provided.

Glassware Setup (Continued)

3. Position the round flask into each position on the S-EVAP cover disk.
4. Turn on the condenser water and fill the condensers. Condensers should fill from the bottom.
5. Rotate the unit and check all connections for leaks. If you encounter difficulties, contact the Organomation technical department.

Instrument Controls – Analog Water Bath System

- Toggle Switch -** Located on the front right bath label. Turns power to the bath on and off.
- Thermostat Knob -** Located on the front center bath label. Adjusts the bath temperature.
- Amber Light -** Located on the front left bath label. Indicates heating when heaters are energized, will cycle at temperature.

Instrument Controls - Digital Control Box System

- Digital Controller -** Controls bath temperature
- Timer Controller -** Controls timed functions when selected. Used for bath preheat or automated control of services.
- Time Switch -** Starts or resets timed operation, momentary switch.
- Heat Switch -** Selects manual or timed control of heat system.
- Time Light -** Green, indicates timed operation in progress.
- Alert Light -** Red, indicates timed operation complete or inactive.
- Heat Light -** Amber, indicates heat system is active.

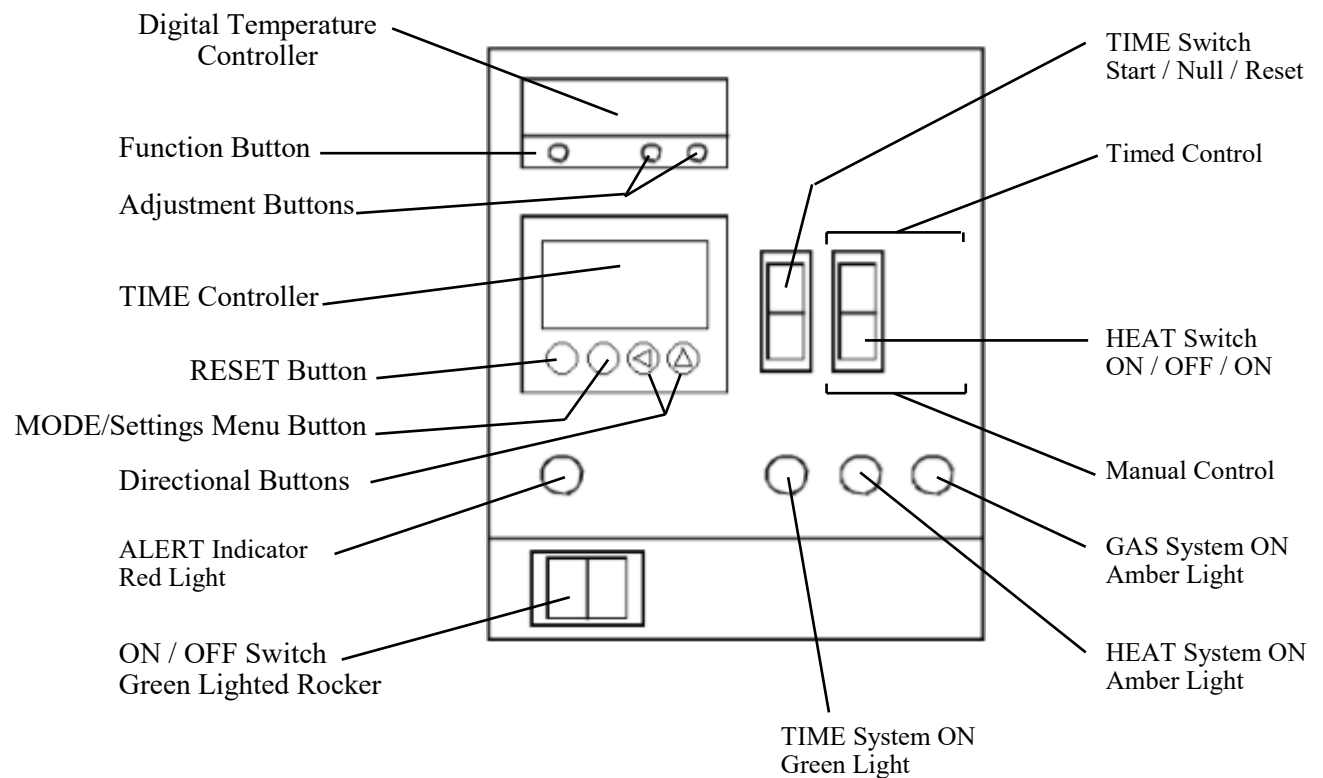

Safety Considerations

READ THIS SECTION BEFORE EQUIPMENT OPERATION!

This equipment is designed for use in the Analytical or Environmental Laboratory by trained laboratory personnel for evaporative applications. Use of this equipment beyond its stated intended purpose and operating parameters is not recommended and will be the sole responsibility of the user. This equipment should not be modified or altered. Organomation assumes no liability for any misuse of or modification to this product and such misuse or modification will immediately void all warranties.

This equipment should be used in accordance with the operating instructions contained in this manual. For alternative uses not covered in this manual, please contact Organomation technical department for product suitability, safety, and alternative operating instructions.

The following are general safety guidelines recommended when using this product. Please consult your laboratory safety officer for any additional safety steps which may be necessary for your specific application or material.

1. Thoroughly review your MSDS (Material Safety Data Sheets) for all chemicals to be used with this equipment.
2. Do not use this equipment with materials with auto ignition points below 100 °C.
3. Hand and eye protection are required when using this product. Additional protection may be required with respect to the materials being used. Please consult your laboratory safety officer.
4. This product should only be used in a chemical fume hood with adequate ventilation.
5. Do not move the product when hot. Scalding from bath water may result.
6. Do not open bath enclosure while energized - SHOCK HAZARD!
7. Repairs of electrical components should be conducted by a trained electrical technician. Incorrect replacement parts or assembly may damage the product and create a serious safety hazard for the user. Factory repair is recommended.
8. Highly flammable materials such as Petroleum Ether should not be used with this product unless the Type-Z Purge positive pressure bath option is installed and operating.

Planning and Preparation

It is important to thoroughly understand the procedures and equipment operation prior to the use of the equipment. High speed solvent evaporation requires a balance of sample volume, bath temperature, cooling water, correct setup, and adjustment. Improper use can impair performance, contaminate samples, or result in sample loss. Environmental and operating conditions are also important, examples include use of water or oil based heating media, glass cleaning techniques, and sample handling procedures. If you are unfamiliar with the use of the S-EVAP System or are working with a new procedure, it is recommended that a trial run be made using a sample blank to determine optimal operating conditions.

The S-EVAP System is designed to handle multiple samples simultaneously up to the capacity of the equipment (8 or 10 positions).

CAUTION!!!

Samples containing ether based, fuel, munitions, or other extremely flammable or explosive materials, compounds, or residues should not be used in this equipment unless the heating unit is equipped with the TYPE -Z Purged Positive Pressure Bath Option.

Even equipped with this option, extreme care and caution must be exercised when using these materials. The equipment must be placed in a location with adequate ventilation and safe guards, recommendations include fire suppression system, shatter proof glass, and adequate shielding for personnel. No other electronic devices should be in the same location unless they are either Z-Purge protected or are explosion proof. No flammable solvents should be stored in this location. Materials capable of forming peroxides prior to or during evaporation must be stabilized with sufficient anti-oxidant or they should not be used.

Under no circumstances should this equipment be used with materials capable of auto ignition below 150 Degrees Centigrade including materials containing peroxides.

Please Contact Organomation Associates Technical Support if you have any questions concerning the use of TYPE-Z Purged equipment or questionable materials in OAI equipment.

Bath Operation

1. Press the reset button on the GFCI (if present).
2. Check bath water level, fill if necessary.

Analog Water Bath Systems

1. Turn the bath toggle switch on.
2. **Thermostat Control** - Adjust the bath thermostat to the desired temperature. S-EVAP water bath maximum temperature is 100 °C.
3. Allow the bath to heat to the desired temperature and stabilize.

Digital Control Box Systems

1. Turn the bath rocker switch on.
2. **Digital Electronic Control** - Adjust the digital controller to the desired temperature set point.

The controller set point may be adjusted by depressing the “*” on the front panel and depressing the up or down arrow keys to the desired temperature. Release the “*” key when the temperature desired is shown on the display. This setting will be retained even after the system is turned off.

To view the current set point, depress and hold the “*” key. Release when done.

Note: The controller set point can be set above the maximum heating capability of the bath it is mounted in. Doing so will cause the bath to operate continually at 100% heat without temperature control. This type of operation defeats the purpose of the controller, may cause a safety problem, and is not recommended.

S-EVAP water bath maximum temperature 100 °C.

3. Manual Heat Control
 - A) To operate the heat system manually, depress the heat switch to the lower position. The Amber heat light will glow indicating the heat system is active. Temperature will be controlled by the digital temperature controller.
 - B) To turn off the heat service, simply return the switch to the middle “OFF” position.











Bath Operation (Digital Control Box Systems – Continued)

4. Timed Heat Control

The time control system allows several operating modes which can be set for different operations. The timer may be used to preheat the bath in the morning prior to use, to shut down the system after a specific period of time (unattended operation), or for non-dryness end point operations.

Preheat Bath Timed Operation

To begin heating the bath automatically prior to use the following morning, please follow the procedures below.

- A) Fill the bath with water to within 0.5 inches of the bath rim or up to the overflow port if so equipped.
- B) Turn the bath on.
- C) Hold the MODE  button until menu screen appears.
- D) Screen to read “out.n” to select output operation  mode, use directional arrows   to select program “ond.1” (On Delay). Hit MODE  once to continue to select time range.
- E) Select time range under “t.rnG”, use directional arrows   to determine the desired range using h (hour), m (minute), s (second).
 Hold MODE  to return to standby.
Other menu options are not vital to the Preheat Bath process.
- F) In standby, calculate the amount of time that will elapse from the point the bath will be left until it will be needed the following day less 1 hour for heat up time.
 Example: You leave at 5:30 PM and plan to arrive at 7:00 AM and want the bath heated and ready to go.
 Elapsed time is 13.5 hours less 1 hour for heating leaves 12.5 hours.
 Use directional arrows   to set desired time, for this example: 12^h30^m.
 Hit MODE  once to confirm time.
- G) Set the heat switch to timed operation.
- H) Set the gas switch to the middle position (OFF).
- I) Press the start switch to begin the timed countdown operation. At the completion of the operation the bath heat will be turned on automatically.

Bath Operation (Digital Control Box Systems – Continued)**Automatic shutdown of heat services - unattended operation**

To shut down the bath services after a period of time during a sample evaporative run, ideal when each sample is to be taken to dryness and the operator will not be present at the completion of the run. Please follow the procedures below.

- A) Hold the MODE (MD) button to enter menu screen.
- B) Screen to read “out.n” to select output operation mode, use directional arrows to select program “ofd” (Off Delay). Hit MODE (MD) once to continue to select time range.
- C) Select time range under “t.rnG”, use directional arrows (←) (→) to determine the desired range using h (hour), m (minute), s (second).

Hold MODE (MD) to return to standby.

Other menu options are not vital to the Preheat Bath process.

- D) In standby, use directional arrows (←) (→) to set time that is most ideal for the period necessary to process the sample.

Example: You wish to process 8 samples. Experience has shown that this takes approximately 5 hours to complete. It is already 3 PM and you expect to leave before 6. Use the automatic time system to shut off the bath heat after you leave:

Evaporation time is 5 hours plus 30 minutes for variance, this gives 5.5 hours. Set the timer as follows: 5^h30^m

Hit MODE once to (MD) confirm time when set.

- E) Set the heat switch to timed operation or manual to bypass timed control.
- F) Press the start switch to begin the timed countdown operation. At the completion of the operation the gas flow will be turned off automatically.

NOTE: To stop a timed run at any point simply push the reset switch.

Bath Operation (Digital Control Box Systems – Continued)**Non-dryness automated endpoint - unattended operation**

The S-EVAP system may be used for timed non-dryness endpoint evaporation. In order for this operation to be successful the following parameters must be maintained.

Flask Size -	All flasks must be the same size
Sample Volume -	All sample volumes must be equal
Bath temperature -	The same set point must be used for each run

A trial run must be made to determine the time required to obtain the specific endpoint desired. Careful notes should be maintained on all operating conditions. Sample size, volume, and temperature are the most important. Please follow the procedures outlined in the previous section for operation of the timed system with unattended operation and shut down.

The following procedures will help to improve accuracy for each run.

- A) Set the temperature for methylene chloride evaporation to 92 °C.
- B) Set the timed heat control to stop heating when the sample level drops to the desired end point.
- C) Predryness residency time can be increased from 5 minutes to as much as 15 minutes when bath temperature drops from 92°C to 88 °C.
- D) Maintain a log of all operating conditions and positions for future use.

Type Z-Purge Bath Operation - Optional

What It Does

The Type-Z Purged system prevents ignition of flammable materials caused by contact with electrical components inside the heating unit.

How It Works

The concept behind this purge system is to create a small positive pressure gradient inside the bath case. By carefully sealing the heating unit or control enclosure, a small flow of clean air or inert gas will create a slight positive pressure within the enclosure. It is important to note that there is constant leakage out of the enclosure. In this way the enclosure is continually purged. The pressure gradient prevents flammable vapors and occasional spills from entering the enclosure where arcing components or high surface temperature heaters might cause ignition. The use of an inert gas such as nitrogen enhances the technique by removing all oxygen from the enclosure. By purging the enclosure for 10 minutes, the gas volume within the enclosure is replaced multiple times ensuring that no flammable vapors remain which may have entered while the purge system was inactive.

Operating Procedure

1. Turn on the gas flow to the Z-Purge System. Purge gas may be clean air or inert gas such as Nitrogen. The use of Nitrogen is recommended.
2. Adjust the gas flow until 0.5 inches water pressure is maintained on the gauge mounted on the heating unit.
3. Purge the bath for 10 minutes before engaging the electrical system. This applies to both the active and passive versions.
4. After 10 minutes the gas flow may be adjusted to 0.1 inches water pressure
5. Turn on the electrical heating unit. The purge rate must be maintained.
6. Proceed to the next section.

Instrument Operation

1. Turn on the condenser water system. Adjust the condenser water flow to a minimum of 2500 CCM for eight positions. When operating with less than eight condensers in place and connected, the flow may be adjusted downwards. Minimum flow for one condenser installed is 1000 CCM.

Condenser water temperature should be below 15 °C. When it is above this temperature, percent of solvent recovered will be reduced. Flow may be increased to 3000 CCM if needed. The condenser system should never be exposed to an incoming water pressure greater than 35 PSIG.

2. Load the glassware with samples into the system.
3. Set the heat system to either manual or timed operation. It is recommended that the system be at operating temperature when samples are loaded.
4. Cover unused positions on the cover disk with the hole covers provided.
5. When the sample run is complete, remove the glassware from the system. The condensers may remain in the unit.
6. Hot solvent vapor present in the glassware should be allowed to cool and condense into the solvent flask. This will reduce solvent loss to the environment and help rinse the glassware.
7. A small amount of solvent should be used to rinse the glassware in non dryness applications. In no event should rinse solvent exceed 10 ML total volume in the concentrator tube.
8. Disassemble the glassware.
9. Carefully remove the solvent recovery flasks and drain them into an approved waste solvent collection container.
10. Turn off the unit.
11. Clean as necessary and prepare for the next run.

Maintenance and Cleaning

The S-EVAP Evaporation system is manufactured from extremely durable materials and may last for years if operated and maintained properly. The following guidelines are recommended for use with all S-EVAP systems.

Heating Media - Tap water, distilled water, de-ionized water, and bath heating oils may be used. Distilled and de-ionized water are preferred as they reduce scale and mineral buildup on bath walls.

Paraffin (wax) may be used with the Z-Purge option.

Do not use organic solvents as a heating medium.

Algaecide - The use of algaecide in the bath water poses no threat to the water bath and will keep biological materials under control. Algaecide should not be acidic. Verify type of algaecide used to insure that it will not adversely affect the samples being processed.

Recommended Algaecides:

VWR brand - Clear Bath®

Fisher Scientific Brand - Bath Clear®

Follow manufacturer instructions concerning use and disposal of these materials.

Water Changes - The bath water should be changed once per week (recommended), but not less than once per month.

Acidic Environment - When in contact with or exposed to acidic materials, vapors, or samples, the instrument should be cleaned immediately after use and neutralized with a suitable mild base solution of **sodium bicarbonate** or similar material followed by a clean water rinse. Prolonged contact with acidic materials will damage the instrument unless precautions are taken.

Maintenance and Cleaning (Continued)

Immersion - **The bath case is water resistant, not water tight. Under no circumstances should the bath be immersed in any liquid or placed in a location where this may occur. SHOCK HAZARD!**

Cleaning - **The stainless steel components** may be cleaned with a cleaner approved for use with stainless steel. Non abrasive cleaners are recommended to preserve the surface finish, however an abrasive material may be used on areas with heavy mineral buildup. Non abrasive scouring pads are recommended. Steel wool may be used on heavily soiled areas. Rinse all cleaned areas with water using a sponge or towel.

NOTE: Do not rinse electrical equipment under running water!

Recommended Cleaning Agents:

Sheila Shine® - Stainless Steel cleaner and polish	non-abrasive
Simple Green® - All Purpose Cleaner	non-abrasive
Orange Clean® - All Purpose Cleaner	non-abrasive
CameO® - Aluminum & Stainless Steel Cleaner	abrasive
AJAX® Cleanser	abrasive
Comet® Cleanser	abrasive

Decontamination - No hazardous materials are used in this equipment. In the event of a hazardous material spill by the user or outside source, immediately contact your laboratory safety officer or the manufacturer of the material for instruction on cleanup or other decontamination procedures.

Reference your Material Safety Data Sheets (MSDS) for instructions on proper cleanup and handling procedures.

Contact Organomation Technical Department at (978) 838-7300 concerning any issue regarding decontamination and / or for alternative cleaning procedures.

SYMPTOMS	CAUSES	SOLUTIONS
No Power to bath.	Electrical outlet not energized. Bath power cord not plugged in. Internal electrical fault.	Energize electrical outlet. Plug in bath power cord. Contact factory for instructions.
Bath does not heat. (heat light is on)	Bad wire connection. Defective high temperature protection switch. Defective thermostat control	Bath will require service, contact factory for instructions.
No temperature control. (temperature continues to rise)	Defective thermostat control	Replace thermostat, contact factory for instructions.
Bath will not heat above 65 - 75 C.	Open faced bath, no cover disk. One of two heaters defective. Defective high temp. switch Defective temperature control.	Purchase anti-evaporation floats. Replace heater, switch, or thermostat, contact factory for instructions.
Water inside bath.	Water floods in hood. Leaky bath drain fitting. Bath surface spill. Pinhole in bath pan.	Consult factory Disassemble bath, dry all contents thoroughly. Return for service highly recommended.
Rust in bath or equipment.	Use of acidic materials in or near equipment.	Clean carefully with steel wool. Remove source of acidic presence.
Phthalate Contamination	Human error	Exercise better handling procedures, avoid latex gloves, hand cream, rubber tubing.
Inconsistent evaporation rates.	Variable bath temperatures.	Check operating conditions.
Biological growths in bath	Algae, molds, etc. in bath water	Use algaecide, change bath water once per week.

Service and Returns

In the event a product purchased from Organomation needs service or must be returned please follow the outlined procedures below.

1) **Contact Organomation Technical Support Department**

Before returning any product to Organomation Associates for any reason, please contact the Technical Support Department, toll free at 888-838-7300 or email sales@organomation.com. Support is available Monday through Friday from 8:30 AM to 4:30 PM EST. Support is available free of charge to customers of Organomation in good standing for all products manufactured by Organomation.

2) **Pack the product for return shipment**

The product should be packaged in its original shipping carton if available. If other packaging is required, use a suitable shipping container which will allow a minimum of two (2) inches clearance between the product and the side walls of the shipping carton. Peanuts, semi rigid foam, cardboard, and other items may be used inside for packaging. Care should be taken when packaging heavy items. Some packaging, such as peanuts, will allow the item to shift in transit and may result in damage.

3) **Insurance**

Most common carriers offer insurance. UPS and Federal Express automatically insure your product up to \$100.00 without charge. It is highly recommended that you insure your product. **Organomation is not liable for any return shipping damages.**

4) **Documentation**

When returning items to Organomation, a Return Authorization Form must be included with the following information: Contact persons name and phone number, return address, and statement of the problem.

5) **How will your return be handled?**

Organomation will evaluate the returned item for damage. If the return is a repair, the product will be examined for problems and a repair estimate will be made. The contact person will be contacted, at which time a Purchase Order will be requested. After the PO is issued, the product will be repaired and return shipped. Most repairs are done within a 24 hour period. Return for credit items will be evaluated and your account credited after the item is received. The contact person will be notified immediately in the event shipping damage has occurred.

Shipping - Claims for damage and shortage

Organomation makes a sincere effort to ensure your purchase is properly packed and all items listed on the packing slip are in fact enclosed with the shipment. In the event that your purchase is damaged or if any items are missing, please follow the procedures below.

- 1) All packaging materials must be retained until the issue is resolved.
- 2) Thoroughly search all packing materials for the missing items. Review your packing list for back ordered items and the manual for a list of items affiliated with your purchase.
- 3) Contact Organomation immediately at 888-838-7300 or sales@organomation.com
- 4) If a damaged item needs to be replaced, Organomation will send this item under warranty at no charge. The damaged item must be returned to Organomation. Please follow the instructions listed in the Service and Returns section. **Important - items not returned or which are damaged or destroyed in transit are the responsibility of the customer and will be billable.**
- 5) No claims for shipping damage or shortage will be accepted after 15 days of receipt of the items by the purchaser.

All items should be returned to:

**Organomation
266 River Road West
Berlin, MA 01503**

Specifications (includes available options)

- Environmental:** Humidity 0-90%, Temperature 5-40°C, Indoor use only.
Elevation up to 3000 Meters.
- Electrical Requirements:** 120 or 240 VAC single phase, non-switchable, 50 - 60 Hz.,
3 wire grounded outlet required.
Model 12060 Bath 1100W
Models 12090 & 12008 Baths 1400W
- Electrical Compliance's:
(as marked on bath)** EC compliance EN55014.
- Bath Water:** Regular tap, distilled, or de-ionized water.
Manual addition
- Sample Sizes Accepted:** 125, 250 & 500mL flasks
**(consult factory for
instrument configurations
to match your needs)**
- Sample Types Utilized:** Organic Solvents with Boiling Point range 30 - 70 Celsius.
- Safety Provisions:** 3 wire grounded power cord.
High Temperature Protection Switch
Stainless Steel construction.
Temperature controlled bath.
Optional Type-Z positive pressure bath purge - Type Z Purged
equipment has not been tested for UL approval.

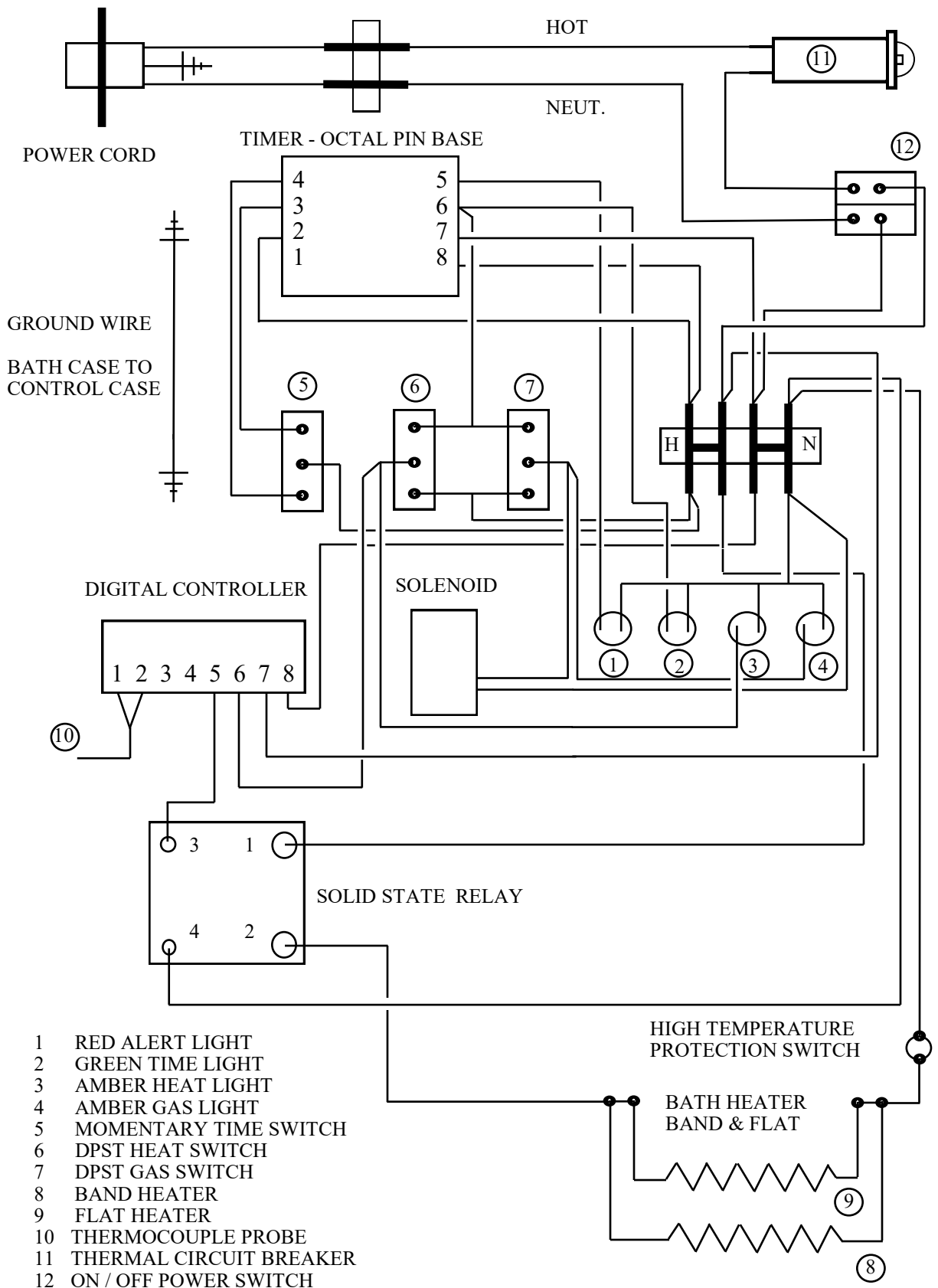

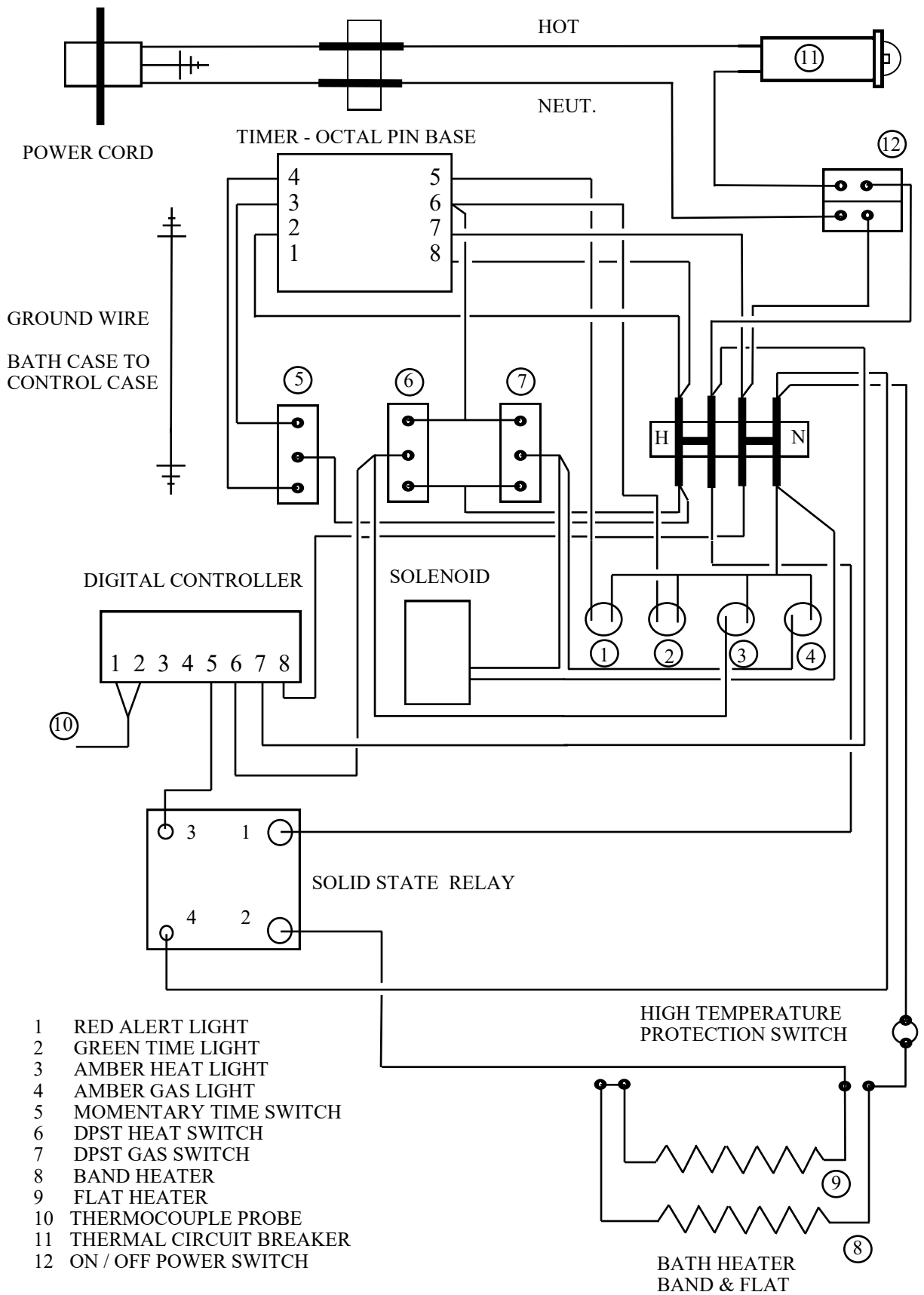

CE Declaration of Conformity Revised June 1, 2015

We, Organomation Associates Inc a corporation registered in Massachusetts, United States of America, declare under sole responsibility that the following equipment to which this declaration relates, meets the principal protection requirements and is in conformity with relevant sections of the applicable CE standards and other normative documents. If changes are made to the products covered by this declaration then the declaration is no longer valid.

Equipment type: Laboratory sample preparation instruments.
Bench top size, multiple sample position.
Analytical evaporators and extractors.

Model(s): N-EVAP Nitrogen evaporator models:
11106, 11155, 11250, 11634, 11645
MULTIVAP Nitrogen evaporator models:
11364, 11300, 11809, 11830, 11848, 11880
11801, 11803, 11815, 11824
S-EVAP solvent evaporator models:
12060, 12080, 12008
12027, 12037, 12010, 12018, 12048

Rot-X-Tract-S solid-liquid extractor models:
13070, 13090, 13008
Rot-X-Tract-L liquid-liquid extractor models:
13318, 13308

All of the above wired for 110 and 220 volts (-2 option code).
All of the above with dry bath and aluminum beads (-DA option code).
All of the above with acid resistant coatings (-RT option code).
All of the above with positive pressure, purged bath case (-Z option code).

EC Directives and Amendments: 89/336/EEC - Electromagnetic Compatibility Directive (EMC).

Harmonized Standards and IEC publications used: EN61326, EN61010-1

Authorized signature	Title	Date
	President	June 1, 2015

CE Declaration of Conformity 2015