

Organomation[®]

N-EVAP[®]

Nitrogen Evaporation System

Models

11106-O (6 Position)
11155-O (12 Position)
11250-O (24 Position)

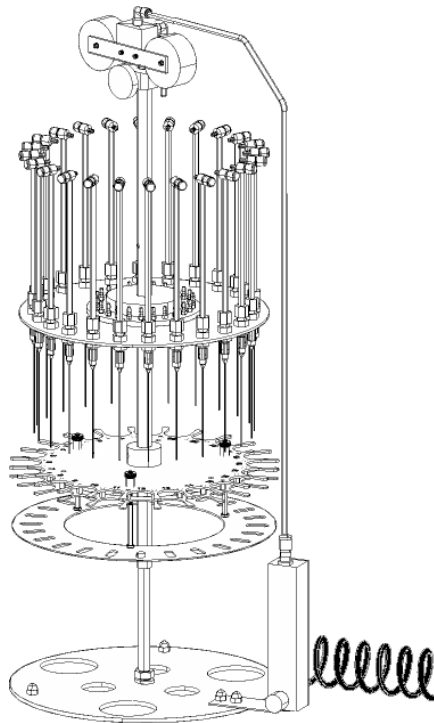

INSTRUCTION MANUAL

266 RIVER ROAD WEST
BERLIN, MA 01503
U. S. A.

Tel: 888-838-7300

Fax: 978-838-2786

Email: sales@organomation.com

Introduction

Instrument Items Shipped..... 1

Instrument Description..... 3

Safety Considerations - Read before operation 4**Installation**

Instrument Part Identification..... 5

Instrument Setup..... 6

Options

Pressure Reducing Regulator..... 14

Pasteur Pipette Adapter and Flow Controller..... 15

Operation

Planning and Preparation..... 16

Instrument Operation..... 17

Maintenance and Cleaning..... 22**Trouble Shooting**..... 23**Technical Information**

Service and Returns..... 24

Shipping - Claims for damage or shortage..... 25

Specifications..... 26

Dear Customer,

Thank you for choosing a Sample Preparation Instrument from Organomation Associates. We appreciate your business and believe that the instrument and accessories you purchased will work very satisfactorily for many years to come. Whether you have added another instrument to your laboratory, or have purchased one for the first time, we will stand behind our equipment.

Should you have questions regarding the set up or operation of this instrument or questions regarding other Organomation products please contact us. The toll free telephone number for sales support and customer service is 888 838-7300. If you purchased the instrument through one of our dealers you should contact them first.

Any comments from you would be much appreciated. We listen to our customers which, in turn, enables us to provide the best instruments available. Please fill out the Warranty and Service Registration Form and return it within ten days of receipt of instrument. Once we have the completed form, your warranty will be activated as stated. The Warranty Form can be mailed or faxed to us at 978 838-2786.

The operating manual contains literature and product lists describing our complete line of laboratory instruments. It provides a convenient way to order new instruments, accessories or repair parts. If you need a verbal or written quote on specific items please call us at our toll free number or e.mail us at the address above.

Again, thank you for selecting ORGANOMATION ASSOCIATES products.

Sincerely,



Andrew McNiven
President

Items Shipped

Carefully check the contents of all cartons received for damage which may have occurred in transit. Retain all cartons and packaging materials until all components have been checked against the packing slip, the component list below, and the equipment has been assembled and tested. Contact Organomation immediately if any damage or discrepancies are found.

Your shipment should contain one or more of the instruments shown below. Option codes are listed on the next page.

Cat #	Instrument Size
11106-O	6 Position N-EVAP Nitrogen evaporation system
11155-O	12 Position N-EVAP Nitrogen evaporation system
11250-O	24 Position N-EVAP Nitrogen evaporation system

NA1221	Flowmeter Assembly with Mounting Bracket & Connector Tube 0-10 LPM for 6 and 12 position N-EVAP
NA1521	0-20 LPM for 24 position N-EVAP
NA0603	19ga x 4" Stainless Steel Luer Lock Needles, blunt end 6 Needles for 6 Position N-EVAP 1 Dz for 12 Position N-EVAP 2 Dz for 24 Position N-EVAP
P1230	Stainless Steel Gas Tube 1/4" (7mm) OD T-Handle Hex Key adjustment tools 1 ea. 1/8" x 6" Long, for 6, 12 & 24 position N-EVAP 1 ea. 5/32" x 6" Long, for 6, 12 & 24 position N-EVAP Manual for N-EVAP models 11106-O, 11155-O, 11250-O
NA0636	Pasteur Pipette Adapter, 1 Dozen per set (Optional)
NA0637	Pasteur Pipette Adapter, 1 Dozen per set (Optional)

Option Codes and additional items shipped

The following list contains option codes and items which may have been shipped in conjunction with the standard parts shown on the previous page. Please check your packing list and order information carefully to determine if these items are included in your shipment. For a complete list of available accessories, please refer to the Accessories Section.

Your shipment may contain the following optional items:

Option	Description
-O	6, 12 or 24 N-EVAP Instrument ordered without OA-HEAT water bath, includes a flowmeter mounting bracket (included with flowmeter) for direct mounting to stand base versus to the bath.
-P	Pasteur Pipet Adapters replace SS needles on the N-EVAP. 1 or 2 dozen are provided with the respective N-EVAP size ordered, reference part # NA0636.
-RT	6, 12 or 24 Position N-EVAP Instrument and are coated in PTFE Instrument is black in color.
-T	SS Needles 19 gauge x 4" (100mm) Long, are coated in PTFE and are black in color.

Instrument Description

The N-EVAP Nitrogen Evaporation System is designed for general evaporation of analytical or biological samples in a variety of test tube based glassware under controlled and reproducible conditions.

The instrument portion is circular and is designed to hold test tubes from 10 to 30 mm OD. The unit will rotate in any direction and may be raised or lowered at will. All units have spring lift assemblies. The instrument may be used with OA-HEAT or other heating baths or may be ordered as a standalone unit. Construction is primarily 304 and 316 stainless steel, anodized aluminum, chrome plated brass, and Delrin (Acetal). Unit may be used with SS needles or disposable glass pipets. Coating in PTFE is available for acidic applications. All tubing provided is phthalate free.

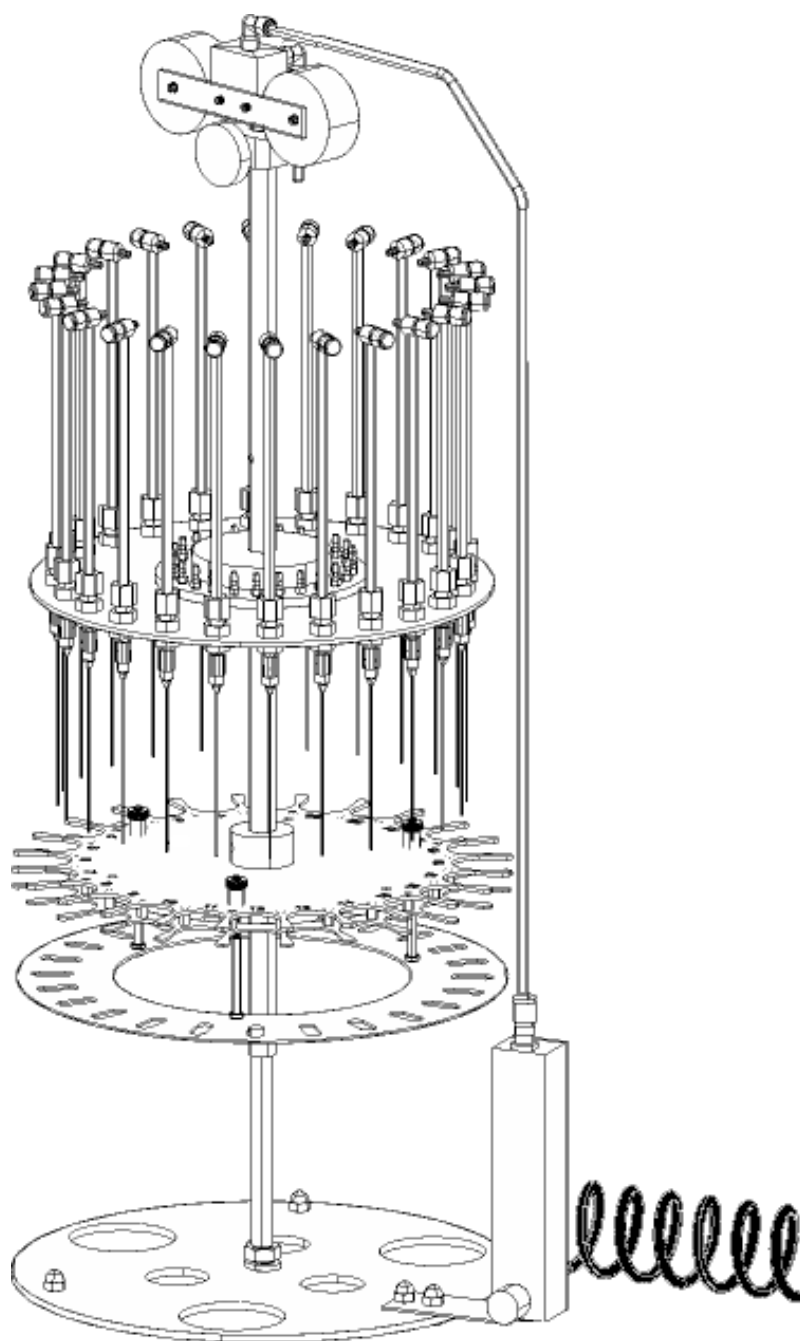

Safety Considerations

READ THIS SECTION BEFORE EQUIPMENT OPERATION!

This equipment is designed for use in the Analytical or Environmental Laboratory by trained laboratory personnel for evaporative applications. Use of this equipment beyond its stated intended purpose and operating parameters is not recommended and will be the sole responsibility of the user. This equipment should not be modified or altered. Organomation assumes no liability for any misuse of or modification to this product and such misuse or modification will immediately void all warranties.

This equipment should be used in accordance with the operating instructions contained in this manual. For alternative uses not covered in this manual, please contact Organomation Technical Support at 978-838-7300 for product suitability, safety, and alternative operating instructions.

The following are general safety guidelines recommended when using this product. Please consult your laboratory safety officer for any additional safety steps which may be necessary for your specific application or material.

1. Thoroughly review your MSDS (Material Safety Data Sheets) for all chemicals to be used with this equipment.
2. Hand and eye protection are recommended when using this product. Additional protection may be required with respect to the materials being used. Please consult your laboratory safety officer.
3. This product should be used in a chemical fume hood with adequate ventilation.
4. Incorrect replacement parts or assembly may damage the product and create a serious safety hazard for the user. Factory repair is strongly recommended.
5. Use of acidic or base materials may damage this product and are not recommended unless the product was ordered with the optional protective coating in PTFE .

Assembly Instructions:

Gather and identify all components.

Instrument

- | | |
|------------------------------------|--------------------------------|
| A. Stand | H. 8 Inch Rod |
| B. Sample Holder and Sample Spring | I. Gas Tube |
| C. Tube Fitting | J. Center Tube Assembly |
| D. Valve Tube Assembly | K. Blunt Needle |
| E. Hoist Pulley and Band Spring | L. Support Tray |
| F. Swivel Fitting | M. Flowmeter and Bracket |
| G. Filter | N. Silicone Tubing (Not Shown) |

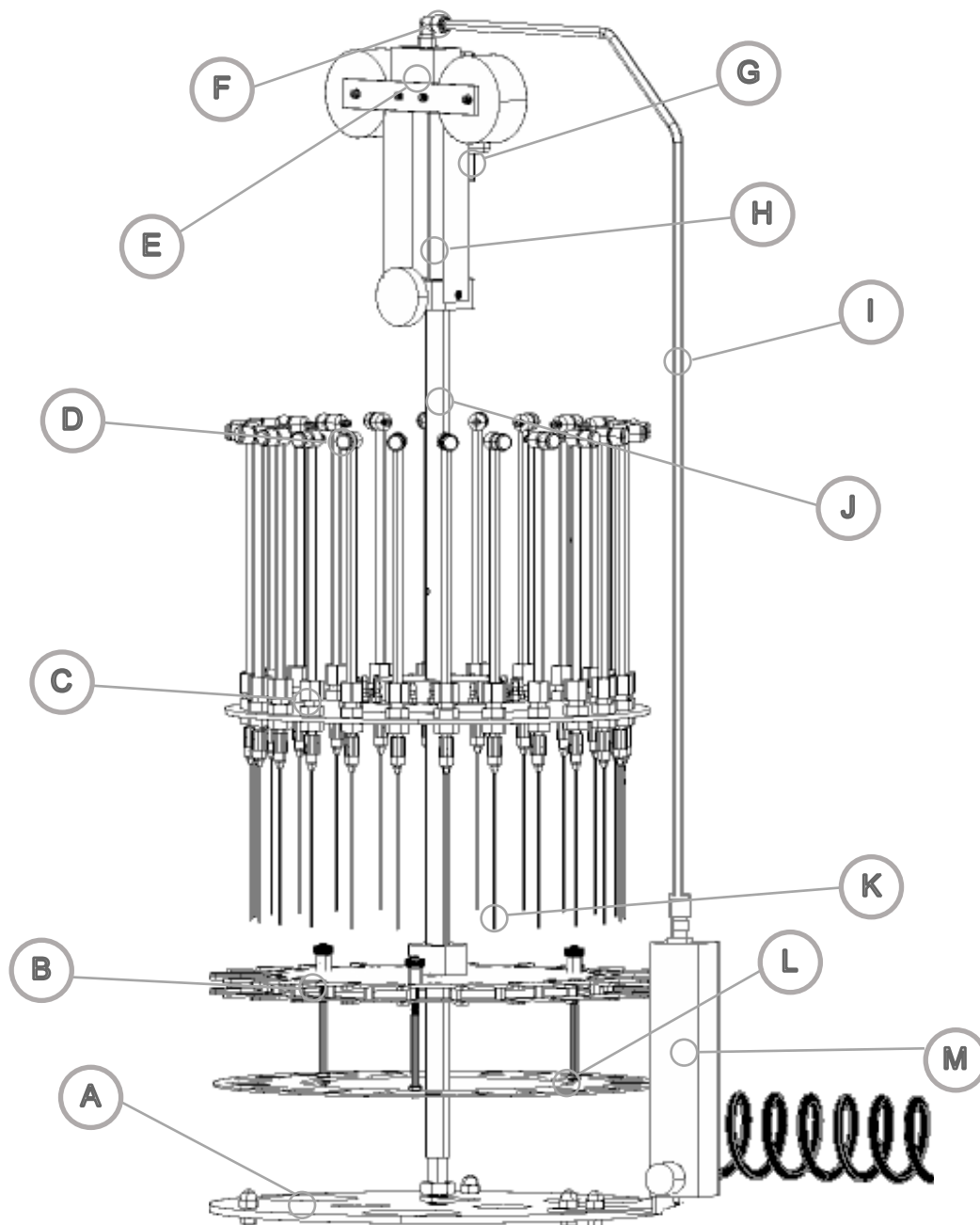

Instrument Setup

1

Place the instrument stand [A] onto a flat level surface.



2

Sleeve the instrument over the instrument stand.

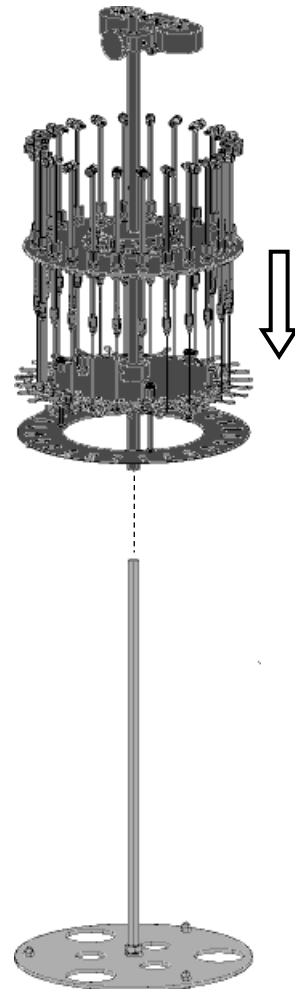

3

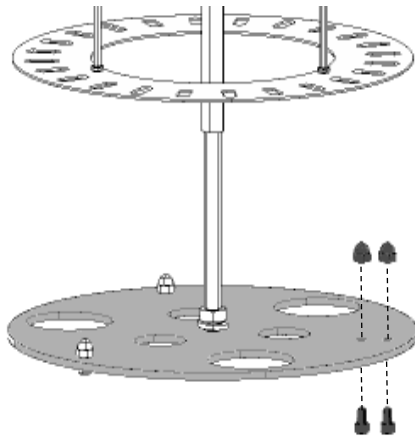

Rotate instrument stand so that the side with 2 nuts is on the right.

Remove the cap nuts on those feet.

4

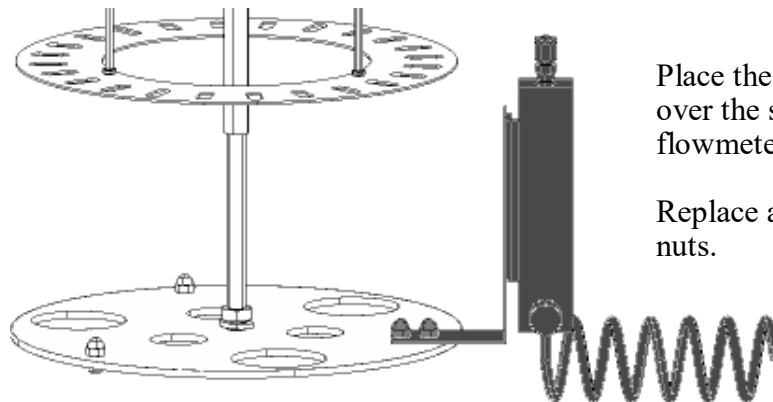

Place the flowmeter bracket over the screws so that the flowmeter faces forward.

Replace and tighten the cap nuts.

5

Exploded View

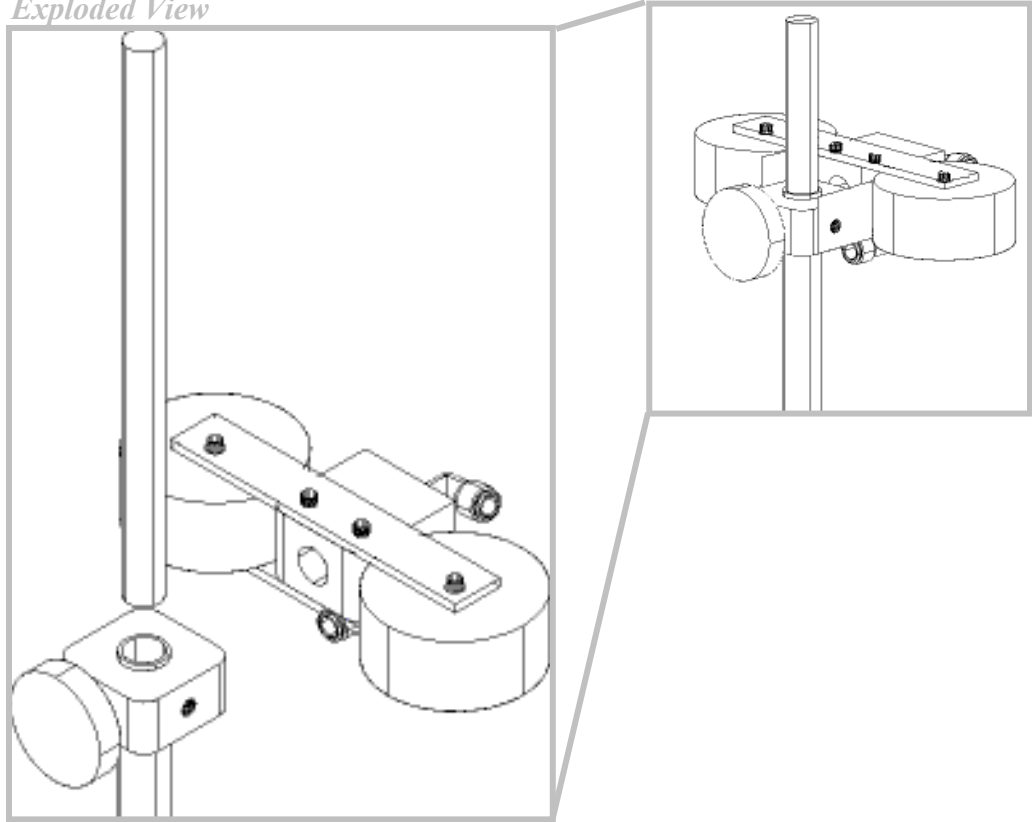

a

Loosen the thumb screw at the top of the instrument.

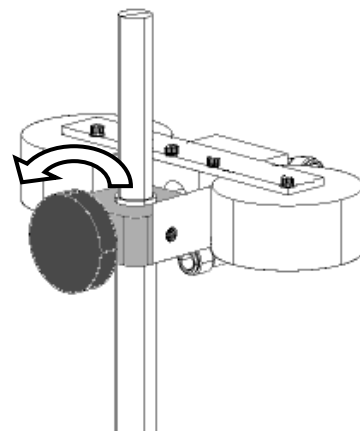

b

Raise the instrument up along the 8 inch rod [I]

Tighten the thumb screw right below the top of the rod.

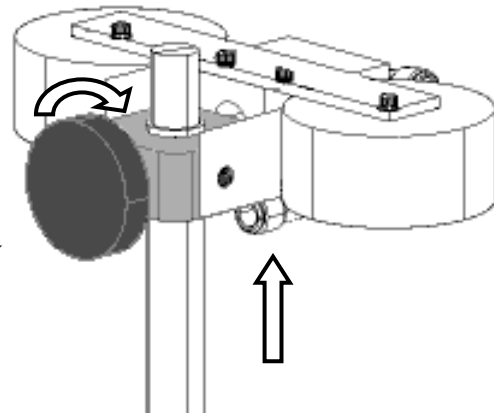
**c**

With both hands, lift and rotate the entire pulley and band spring assembly [F] 90°.

Seat the assembly on the rod.

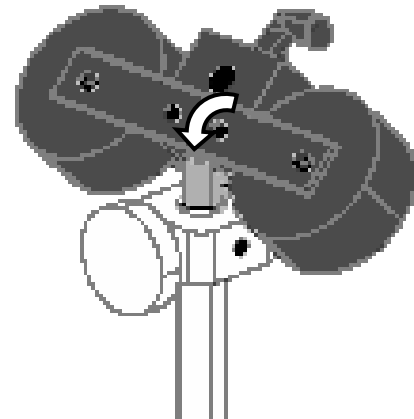

Be careful not to cut hands on the band spring

6

a

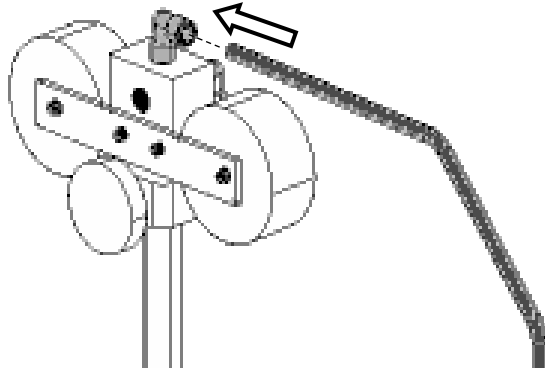

Connect the gas tube [J] into the swivel fitting [G] at the top of the instrument.

b

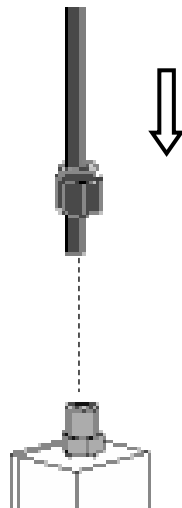

Connect the lower end of the gas tube [J] to the fitting on the top of the flow meter.

Tighten nut with a wrench.

7

To adjust for various test tube sizes:

Turn the thumb screws clockwise to raise the lower support tray.

Turn counter clockwise to lower it.

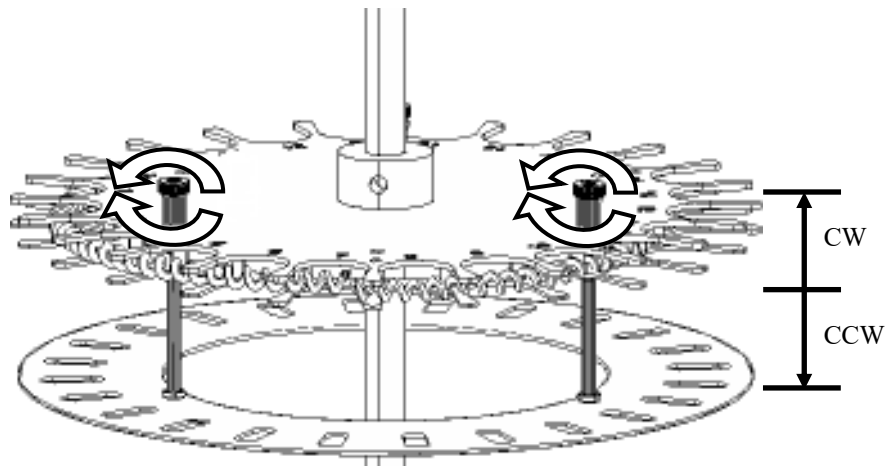

The tray can be tilted to support multiple test tube sizes by unevenly adjusting the thumb screws.

For larger test tubes:

Use a hex key to loosen the upper manifold set screws.

Raise the upper manifold. Aligning it with the secondary hole (approximately 35 mm).

Tighten the set screws to secure in place.

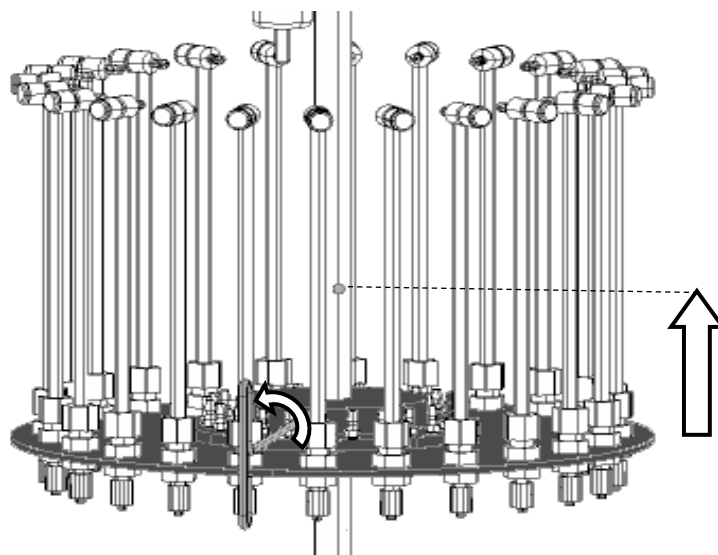

8

The sample holder plate may need occasional adjustment to realign.

Use a hex key to loosen the set screw on the plate collar.

Raise the sample holder to the desired height.

Align the test tube positions so that the valve tubes are centered.

Tighten the set screws to hold the sample holder plate securely.

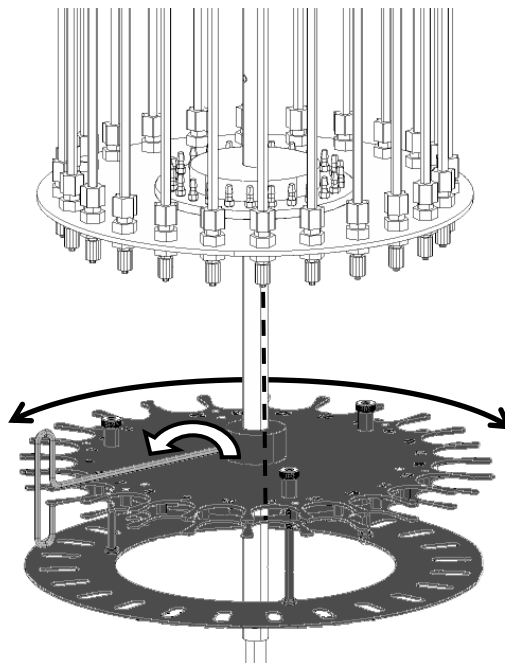

* *The sample tray is originally set to be flush with the top of the bath.*

9

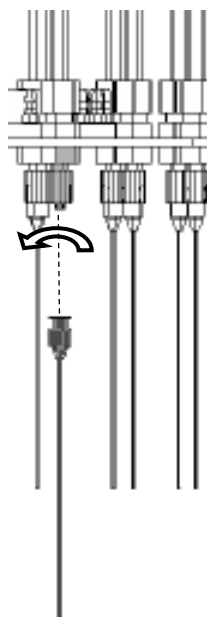

Align the needle hub with the luer fitting.

Rotate the needle 90°.

! **Stainless Steel Needles or Pipette Adapters can be used on this instrument. See page 15 for Pipette Adapter instructions.**

10

Raise all valve tubes to their highest position.

Adjust the tube fitting [D] for controlled valve movement.

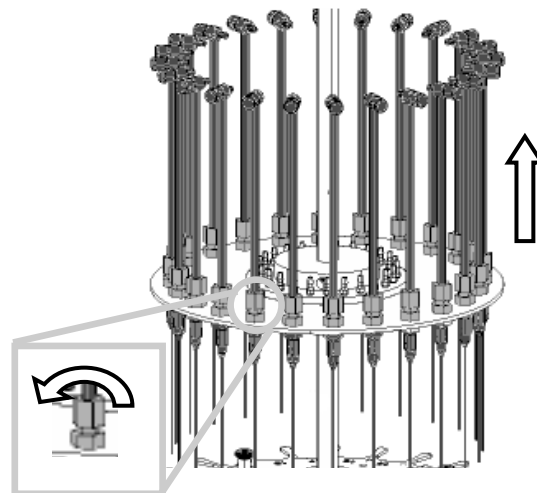

11

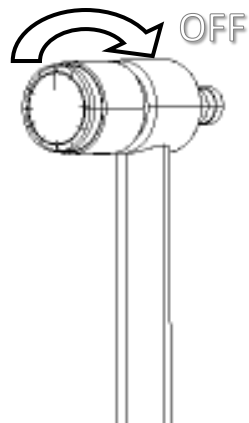

Turn all needle valves clockwise until they are off.

12



Turn the valve on the flowmeter clockwise until it is closed.

Pressure Reducing Regulator Option - NA0630

When used with an Organomation Instrument recommended pressure is 10-30 psi. To install a pressure reducing regulator, please follow the instructions and figure below:

Parts:

- | | |
|---|---------------------------------|
| A. Adapter | D. 1/4" Push to connect fitting |
| B. Yellow tubing | E. Pressure gauge [0-60 psi] |
| C ₁ . 1/4" Push to connect fitting | F. Regulator [One directional] |
| C ₂ . 1/4" Barb fitting | G. Set screw |

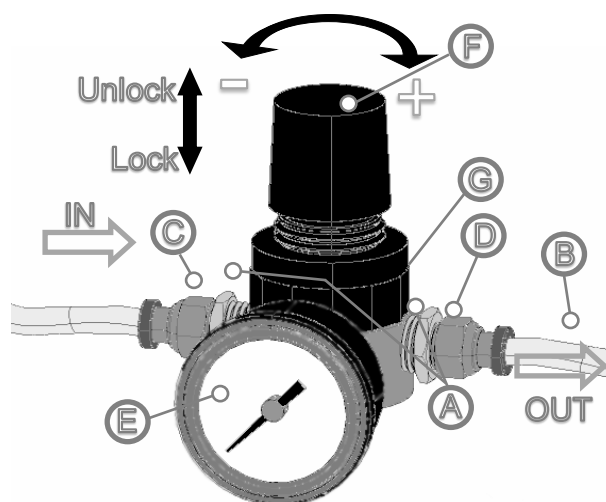
**For 1/4 Outer Diameter (OD) input tube**

- A. Cut yellow tubing [B] to desired length to fit your lab space
- B. Connect yellow tubing to flowmeter or gas input and to the output push connect fitting [D] (the unlabeled side)
- C. Connect source tube to input push connect fitting [C₁] (labeled in)

(Optional) For 1/4 Inner Diameter (ID) input tube

- A. Cut yellow tubing [B] to desired length to fit your lab space
- B. Connect yellow tubing to flowmeter or gas input and to the output push connect fitting [D] (the unlabeled side)
- C. Unscrew push connect fitting [C₁] on the input side (labeled in)
- D. Screw barb fitting [C₂] into input side
- C. Connect source tube to input barb fitting [C₂]

(Optional) Reverse Gauge Position

- A. Unscrew set screw [G]
- B. Unscrew gauge [E]
- C. Screw gauge into reverse side
- D. Screw set screw into remaining hole

Pasteur Pipette Adapter and Flow Controller

Two types of Pasteur pipette adapters are offered. Both are compatible with all N-Evap models.

Pasteur Pipette Adapter and Flow Controller, Male Luer to Fluted Nut - NA0636

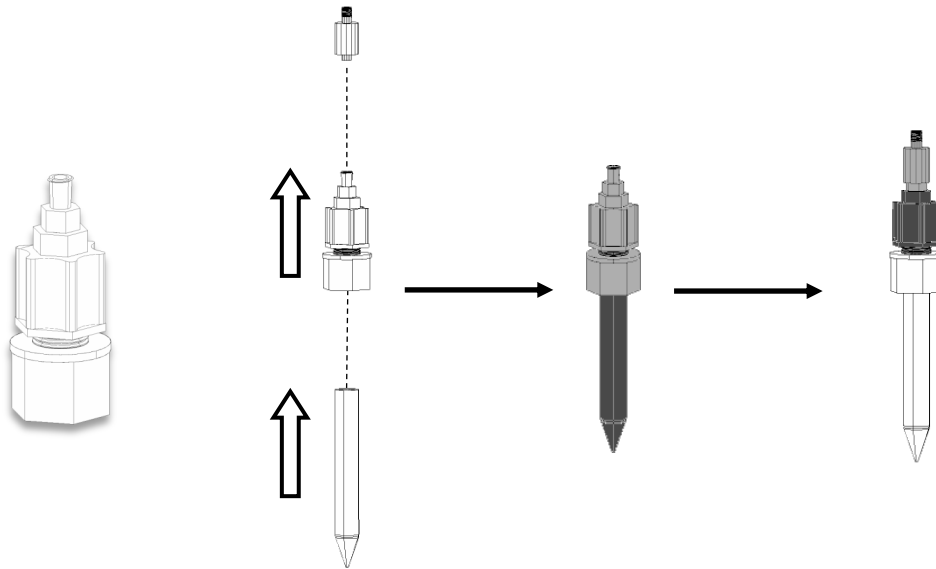

- Loosen the fluted nut
- Push pipette into the fluted nut and tighten.
- Screw the adapter onto the luer fitting like you would a needle.

Pasteur Pipette Adapter and Flow Controller, Male Luer to 1/8 Hose Barb - NA0637

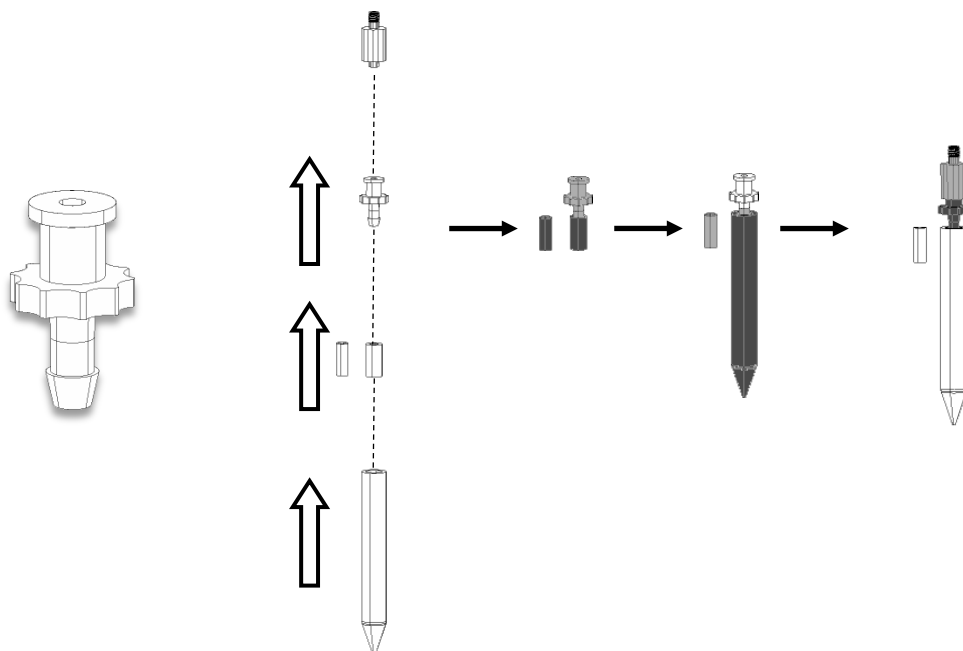

- Choose the tube that fits your pipette.
- Put the tube on the end of the adapter.
- Push the pipette onto the tube on the adapter.
- Screw the adapter onto the luer fitting like you would a needle.

Operation

Planning and Preparation

It is important to thoroughly understand the procedures and equipment operation prior to the use of the equipment. Nitrogen evaporation requires a balance of sample volume, nitrogen flow, needle position and adjustment. Improper use can impair performance, contaminate samples or result in loss of samples. Environmental conditions are also important, examples include use of dry or wet heating media, hood airborne contaminants, gas purge purity, and sample handling procedures. If you are unfamiliar with the use of the N-Evap System or are working with a new procedure, it is recommended that a trial run be made using a sample blank to determine optimal operating conditions.

The N-EVAP System is designed to handle multiple samples simultaneously up to the capacity of the equipment. Glass or plastic tubes with an outer diameter of 10 to 30mm and up to 150mm height may be accommodated. Centrifuge tubes, scintillation vials, small beakers and Erlenmeyers (50 ml) may also be used. Choice of SS needles or disposable glass pipets (adapters) are available.

The N-EVAP System is manufactured utilizing inert materials. The translucent silicone rubber tubing used in the gas distribution system is certified 100% Phthalate free.

Instrument Operation

1

Place the test tubes into the sample holder tray.

The test tubes should rest on the support tray

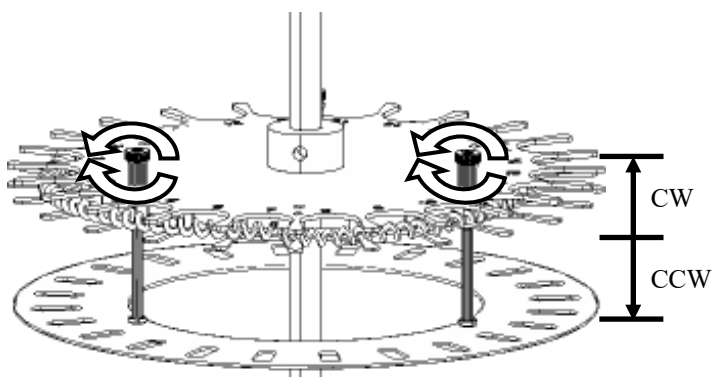
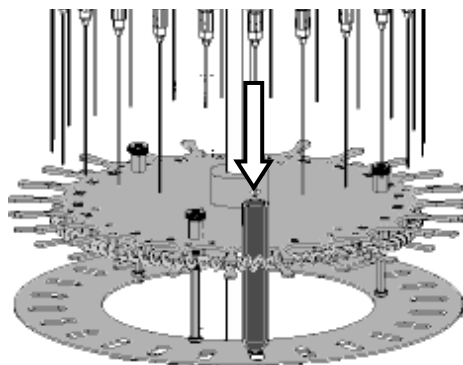

To adjust the support tray:

Turn the thumb screws clockwise to raise the support tray

Turn the thumb counterclockwise to lower the support tray

2

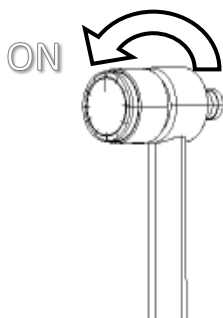

Turn the needle valve one revolution at each sample position being used.

3

Lower the valve tube assembly until the needle or pipet are approximately a 1/4 inch (6.35 mm) from the surface of the solution.

The valve tube nut may be loosened or tightened to allow for easy control.

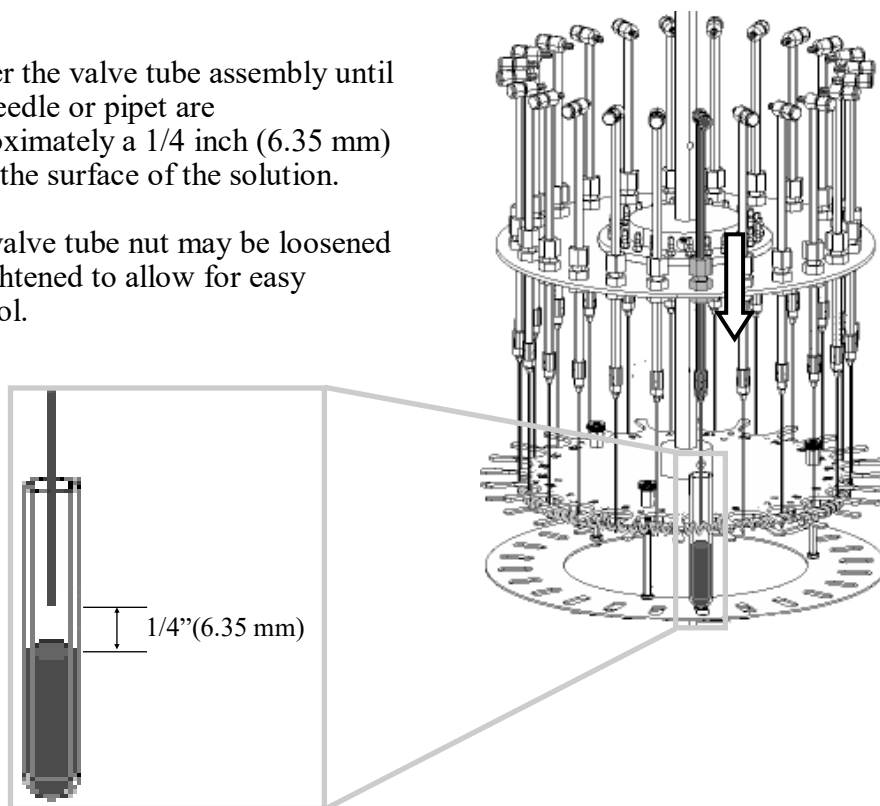

4

Slowly turn the flowmeter valve counter clockwise until the desired flow rate is obtained.

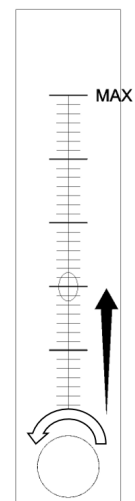
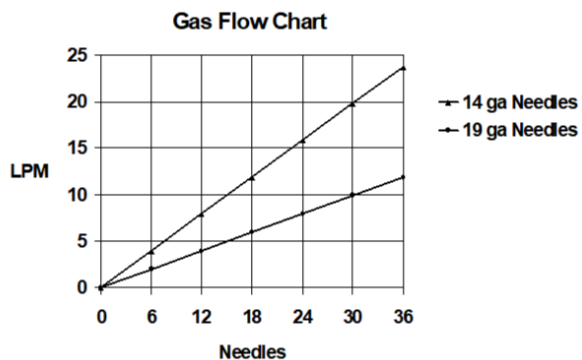

5

Adjust the needle valve of each sample to create a dimple in the surface of the sample.

Adjust the needle tip distance from solution upwards as needed.

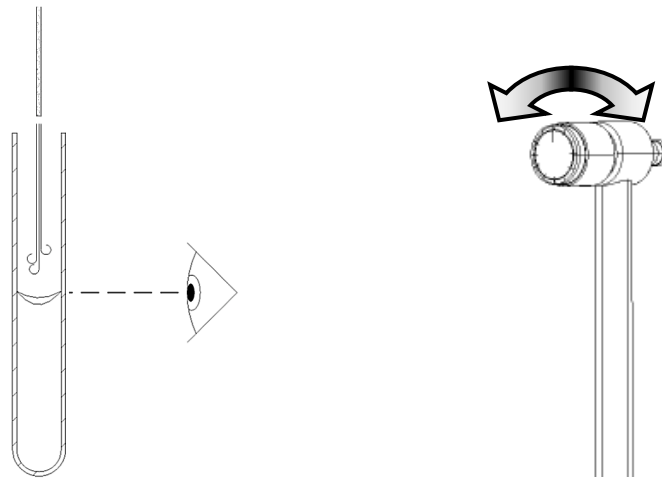

Avoid splashing, as this may cause sample loss and possible contamination.

6

Continue the evaporation until complete.



Evaporation speed can be increased by adjusting the needle position throughout the evaporation process to maintain the dimple on surface of the sample.

7

Remove samples when done by sliding the valve tube assembly upwards and lifting the sample from the sample holder.

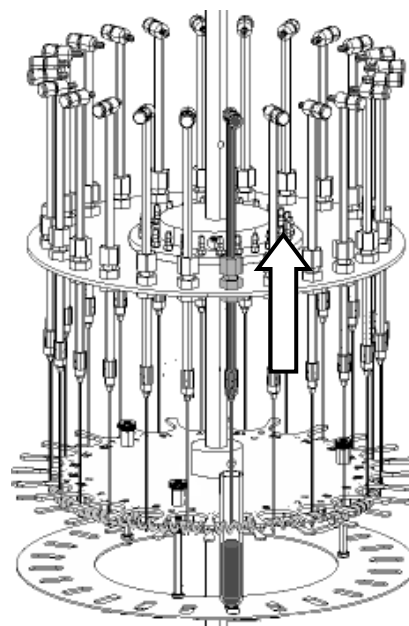

*** Optional:**

At the end of the evaporative process, rinse the needle or pipet tips with one or two drops of solvent using a clean pipette.

This step is optional, but should be used if the following conditions apply: sample splashing occurs, needle or pipet tip is accidentally immersed in the sample, or micro quantities of material are to be recovered.

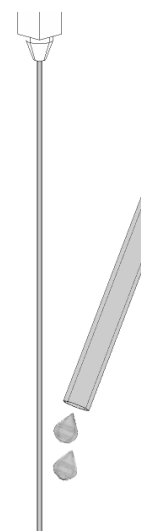

8

When evaporation is complete and all samples are removed, proceed as follows:

a

Turn off the gas source.

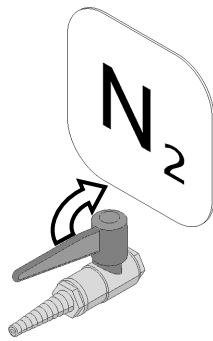

b

Close the needle valves and the flow meter valve.

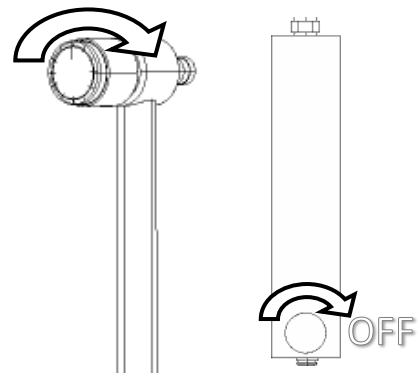

c

Remove and clean the needles.
Pipets should be disposed of properly.



Refer to Maintenance Section for bath and instrument care and upkeep.

Maintenance and Cleaning

The N-EVAP Evaporation system is manufactured from extremely durable materials and may last for years if operated and maintained properly. The following guidelines are recommended for use with N-EVAP systems.

Acidic Environment - When in contact with or exposed to acidic materials, vapors, or samples, the instrument should be cleaned immediately after use and neutralized with a suitable mild base solution of **sodium bicarbonate** or similar material followed by a clean water rinse. Prolonged contact with acidic materials will damage the instrument unless precautions are taken.

Needles - Needles should be solvent cleaned after every use to reduce the chance of contamination. Solvent rinsing, autoclaving, and Soxhlet Extracting are viable techniques.

Cleaning - **The stainless steel components** may be cleaned with a cleaner approved for use with Stainless Steel. Non abrasive cleaners are recommended to preserve the surface finish, however an abrasive material may be used on areas with heavy mineral buildup. Non-abrasive scouring pads are recommended. Steel wool may be used on heavily soiled areas. Rinse all cleaned areas with water using a sponge or towel.

PTFE coated parts (black in color) should be cleaned with non-abrasive materials only, otherwise scratching will result and the coating will be compromised. Rinse with clean water using sponge or towel.

Recommended Cleaning Agents:

Sheila Shine® - Stainless Steel cleaner and polish	non-abrasive
Simple Green® - All Purpose Cleaner	non-abrasive
Orange Clean® - All Purpose Cleaner	non-abrasive
CameO® - Aluminum & Stainless Steel Cleaner	abrasive
AJAX® Cleanser	abrasive
Comet® Cleanser	Abrasive

Decontamination - No hazardous materials are used in this equipment. In the event of a hazardous material spill by the user or outside source, immediately contact your laboratory safety officer for instruction. Reference your Material Safety Data Sheets (MSDS) for instructions on proper cleanup and handling procedures.

Contact Organomation Technical Department at (978) 838-7300 or sales@organomation.com with any questions.

SYMPTOMS	CAUSES	SOLUTIONS
Rust in bath or equipment.	Use of acidic materials in or near equipment.	Clean carefully with steel wool. Remove source of acidic presence.
Phthalate Contamination	Human error	All tubing is Phthalate free. Exercise better handling procedures, avoid latex gloves, hand cream, rubber tubing.
Inconsistent evaporation rates. (or excessive Nitrogen use)	Nitrogen leaks. Incorrect needle valve adjustment	Check all connections, soap/water. Close needle valves - open valves one revolution and adjust flow using flowmeter.

Service and Returns

In the event a product purchased from Organomation needs service or must be returned please follow the outlined procedures below.

1) **Contact Organomation Technical Support Department**

Before returning any product to Organomation for any reason, please contact the Technical Support Department, toll free at 888-838-7300 or email sales@organomation.com to receive a Return Authorization document. Support is available Monday through Friday from 9:00 AM to 4:30 PM EST. Support is free of charge to customers of Organomation in good standing, and for all products manufactured by Organomation.

2) **Pack the product for return shipment**

Please include your Return Authorization form inside your shipment so that the item returned can be easily identified. The product should be packaged in its original shipping carton if available. If other packaging is required, use a suitable shipping container which will allow a minimum of two (2) inches clearance between the product and the side walls of the shipping carton. Peanuts, semi rigid foam, cardboard, and other items may be used inside for packaging. Care should be taken when packaging heavy items. Some packaging, such as peanuts, will allow the item to shift in transit and may result in damage.

3) **Insurance**

Most common carriers offer insurance. UPS and Federal Express automatically insure your product up to \$100.00 without charge. It is highly recommended that you insure your product. **Organomation is not liable for any return shipping damages.**

4) **Documentation**

When returning items to Organomation, a Return Authorization form must be included with the following information: Contact persons name and phone number, return address, and statement of the problem.

5) **How will your return be handled?**

Organomation will evaluate the returned item for damage. If the return is a repair, the product will be examined for problems and a repair estimate will be made. The contact person will be contacted, at which time a Purchase Order will be requested. After the PO is issued, the product will be repaired and return shipped. Most repairs are done within a 24 hour period. Return for credit items will be evaluated and your account credited after the item is received and evaluated for damage. The contact person will be notified immediately in the event shipping damage has occurred.

Shipping - Claims for damage and shortage

Organomation makes a sincere effort to ensure your purchase is properly packed and all items listed on the packing slip are in fact enclosed with the shipment. In the event that your purchase is damaged or if any items are missing, please follow the procedures below.

- 1) All packaging materials must be retained until the issue is resolved.
- 2) Thoroughly search all packing materials for the missing items. Review your packing list for back ordered items and the manual for a list of items affiliated with your purchase.
- 3) Contact Organomation immediately at 888-838-7300 or sales@organomation.com
- 4) If a damaged item needs to be replaced, Organomation will send this item under warranty at no charge. The damaged item must be returned to Organomation. Please follow the instructions listed in the Service and Returns section. **Important - items not returned or which are further damaged or destroyed in transit are the responsibility of the customer and will be billable.**
- 5) No claims for shipping damage or shortage will be accepted after 15 days of receipt of the items by the purchaser.
- 6) Please contact Organomation prior to making any returns.

All items should be returned to:

**Organomation Associates, Inc.
266 River Road West
Berlin, MA 01503**

Specifications

Environmental:	Humidity 0-90%, Temperature 0-40°C, Indoor Use Only.
Gas Services Required:	Nitrogen, clean air, or other inert gas, 5 - 30 Psig, adjustable. Flow indication standard with all complete N-EVAP™ systems.
Sample Sizes Accepted:	Glass or Plastic Test Tubes, 10-30mm Dia. x 10-150mm Long Scintillation Vials Centrifuge Tubes (size range above) Autosampler vials (size range above) 50ml Erlenmeyer Flasks 50ml Beakers Consult factory for optional smaller & larger sizes.
Sample Types Utilized:	Organic Solvents with Boiling Point range 30 - 100 Celsius. Water and aqueous solutions. Strong acidic or base materials, PTFE coating required - consult factory.
Safety Provisions	Stainless Steel construction. Optional PTFE Coating .