

KL 300 LED

Compact and bright



The KL 300 LED is a fiber optic light source with a LED light engine, developed and designed for industrial and life science applications in stereo microscopy and macroscopy.

The brightness is equivalent to a 30 W halogen cold light source.

Features:

- LED light engine.
- Wide range power supply (100 – 240 V, 50 – 60 Hz)
- International clip plug system.
- Convection cooling (no fan).
- Continuous dimming from 0 to 100 %.
- Mountable direct to microscope
- stands via respective adaptors or usable as stand-alone.
- Wide range of accessories available (KL 300 series).

General data		
Part-No.		120 300
Dimensions (W x D x H)	(mm) / (inch)	107 x 114 x 61 / 4.2" x 4.5" x 2.4"
Weight	(kg)	Approx. 0.35
Cooling		Convection
Electrical data		
Operating voltage, frequency		100 – 240 V ~, 50 – 60 Hz
Input voltage	(V)	9
Power consumption	(VA)	max. 5
Protection class		II
Overvoltage category		II
LED		1 high power LED white
LED life time	(h)	50,000 ¹
Illumination data		
Luminous flux	(lm)	80 ²
Color temperature	(K)	Approx. 5,600
Light control		Electrical
Active light guide diameter	(mm) / (inch)	Max. 6 / max. 0.23"
Certification marks		
Marking	CE	CE (power supply: CE, UL, PSE)
EMV-class	B	

Mounting adaptors	
Base stand	158 340
Mounting bracket	120 250
Mounting adaptors	
for microscope and swinging arm stands	
bracket for column Ø 25 mm (0.98")	120 225
bracket for column Ø 29 mm (1.14")	120 229
bracket for column Ø 32 mm (1.26")	120 232
bracket for column Ø 35 mm (1.38")	120 235

¹ max. decline of light output to 70% of origin level

² at the output of SCHOTT fiber optic light guide, 1-arm, flexible, Ø 9 mm active, length 1000 mm



KL 300 LED

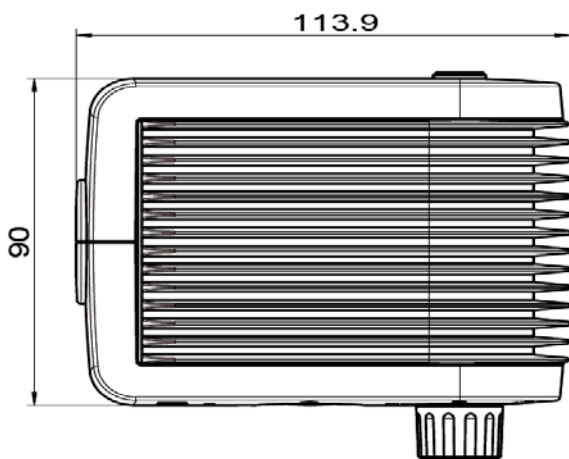
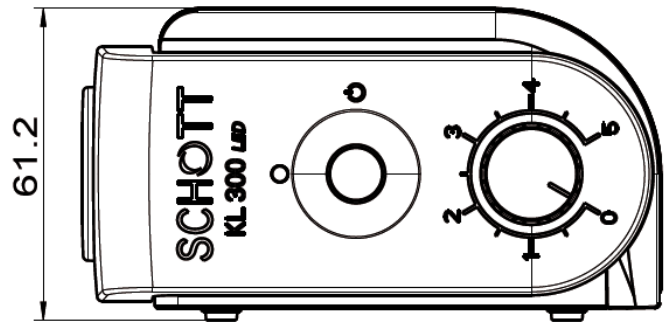
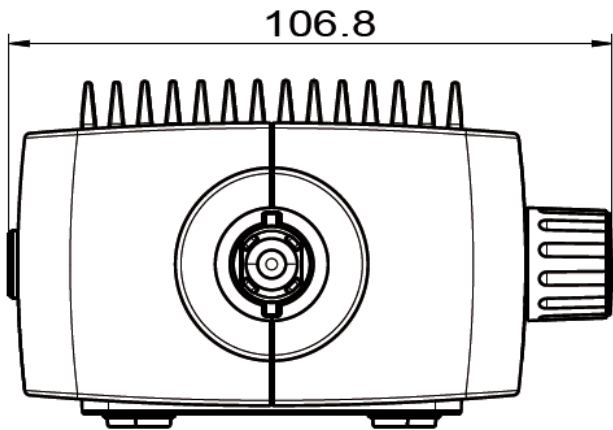

All specifications are subject to change without prior notice. This datasheet or any extracts thereof may only be used in other publications with express permission of SCHOTT. © SCHOTT North America, Inc.

SCHOTT North America, Inc.
Lighting and Imaging
6862 Santa Teresa Blvd.
San Jose, CA 95119 USA
phone: +1-408-363-2100
fax: +1-408-363-9980
microscopy@us.schott.com
www.us.schott.com/lightingimaging

SCHOTT
glass made of ideas