



## NSBR492WSWCR/0

### Product Description

Corepoint® Scientific Blood Bank Refrigerators are designed in accordance with FDA listed Class II medical devices. In addition, blood bank refrigerators also conform to the requirements set forth by AABB for the refrigerated cold storage of blood-based products.

Backed by optimal temperature control and EPA SNAP compliant refrigerants, these high-performance units protect blood, prevent waste, and allow for peak delivery. Corepoint® Scientific blood bank refrigerators utilize smart controllers and feature a full array of alarms, LED interior lighting, stainless steel interiors, sliding drawers and probe access port.

### Images



### Product Data Sheet

49 CF Blood Bank Refrigerator Solid Door Chart Recorder

Temperature Probes <sup>1,2</sup>			
Probe	Ave	Min	Max
1	3.9	3.4	4.5
2	4.2	3.9	4.5
3	3.9	3.6	4.3
4	4.0	3.6	4.4
5	3.8	3.4	4.4
6	4.1	3.8	4.3
7	4.0	3.6	4.4
8	3.6	3.2	4.2
9	3.8	3.5	4.1
10	3.8	3.4	4.2
11	4.2	4.0	4.3
12	4.0	3.7	4.3
13	3.6	3.2	4.0
14	3.8	3.6	4.0
15	3.7	3.3	4.0
Bal	4.2	4.1	4.3
Bag	4.2	4.1	4.3

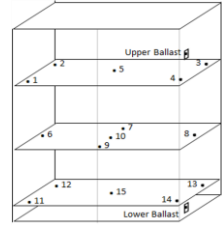

### Temperature Charts<sup>3</sup>

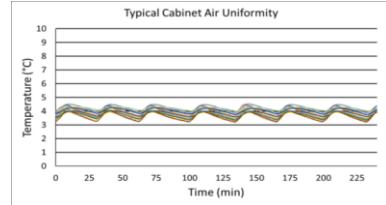
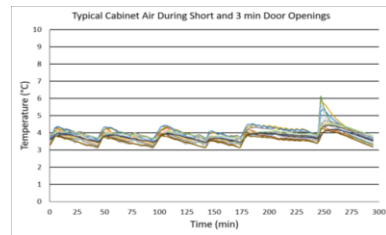

### Certifications



### General Description and Application

Storage capacity (cu. ft)	49 cu. ft gross volume
Door	Double Swing Solid Right and Left Hinged Doors
Shelves	N/A
Drawers	7 drawers standard per door (14 drawers total) with option for 8th drawer per door (16 drawers total), 304 SS drawers, 65 lb. capacity each
Mounting and Installation	4 swivel casters, front casters locking
Interior lighting	Shielded, switched LED lighting, full coverage, balanced spectrum
External probe access	Rear wall port (3/4" dia.)
Insulation	Cabinet is foamed-in-place with EPA compliant high density urethane foam
Exterior materials	White powder coated steel
Access control	Key Lock
General warranty	Two (2) years parts and labor warranty, excluding calibrations
Compressor warranty	Seven (7) years compressor warranty
Product Weight (lbs)	636
Shipping Weight (lbs)	755
Rated Amperage	4.5 Amps
Power Plug/Power Cord	Hospital grade, NEMA 5-15, 9 ft nominal (2.7 m)
Facility Electrical Requirement	110-120V AC: 15 A (minimum)
Agency Listing and Certification	FDA listed Class II medical device, 21CFR part 820 compliant, ETL, CETL Listed (certified to UL471 standard, hydrocarbon refrigerant safety)

### Performance

Uniformity <sup>1</sup> (Cabinet air)	+/- 0.4°C
Stability <sup>2</sup> (Cabinet air)	+/- 0.5°C
Maximum temperature variation (Cabinet air)	+/- 0.7°C
Stability <sup>2</sup> (Simulator ballast)	+/- 0.1°C
Stability <sup>2</sup> (Simulator bag)	+/- 0.1°C
Temperature Rise after Short Door Openings	Temperature did not exceed 4.5°C at any probe
Recovery after Short Door Openings	All probes under 6.2°C throughout opening
Energy <sup>3</sup> Consumption (KWh/day)	1.47
Average <sup>3</sup> Heat Rejection (BTU/hr)	3.27
Noise Pressure Level (dBA)	38 or less installed

Performance data acquired at 22°C ambient, 4°C nominal set point in an empty cabinet with shelves using air probes, during stabilized steady state operation and a DAQ sampling rate of one measurement every 10 seconds

1 - Uniformity is defined as the maximum variance in temperature across all probes at any point in time over the testing period

2 - Stability is defined as the maximum variance in temperature experienced by any single probe over the testing period

3 - Data per Energy Star test results or equivalent testing and calculation. Heat rejection based on daily averages, not continuous operation. Performance exceeds Energy Star requirements.

### Refrigeration System

Compressor	Hermetic, variable speed (VSC). Rated speed range: 1300-4000 rpm
Refrigerant	EPA SNAP compliant, R600a, Isobutane
Condenser	Anti-fouling tube and grid design, ultra-quiet multi-speed fan
Evaporator	Fin and tube design, high efficiency fan
Defrost	Cycle optimized, zero energy

### Controller, Configuration, Alarms and Monitoring

Controller technology	Proportional Integral Derivative (PID) microprocessor with LCD display
Battery Backup	24V high capacity battery, controller, all alarms active, temperature monitoring DAQ and event logging active on battery backup
Display technology	Calibrated, Stainless Steel
Digital Communication	RS-485 (MODBUS)
Data Transfer	Non-applicable
Chart Recorder	6" paper, inkless
Adjustable Temperature Range	1°C to 10°C
External alarm connection	State switching remote alarm contacts
Alarms	Visual and audible indicators, Power failure, Temperature sensor failure, Battery voltage monitor and replacement, High / Low temperature, Door ajar
Simulator Ballast	Upper probe: 4 oz. (120 ml) bottle, 50% glycerol mixture. Lower probe: Solid thermal media
Disclaimers	Indoor use only, +18°C to +26°C (+65°F to +78°F), <70% RH

### Dimensions

	Width (in.)	Depth (in.)	Height (in.)	Door Swing (in.)	Total open Depth (in.)
Exterior	54"	36 3/8"	81 1/2"	24 7/8"	59 3/8"
Interior	49 1/8"	26 1/2"	59"		

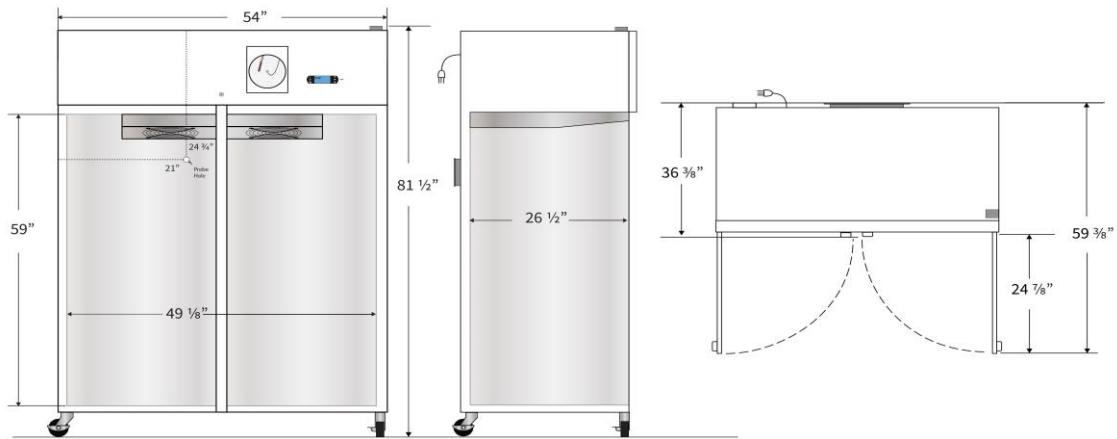

### Contact

Customer Service	800-648-4041 Option 3	<a href="mailto:customerservice@horizontscientific.com">customerservice@horizontscientific.com</a>
Technical Service	800-648-4041 Option 5, Parts Option 4	<a href="mailto:technicalservice@horizontscientific.com">technicalservice@horizontscientific.com</a>