

CARBOLITE®

IGERO 30-3000°C

Installation, Operation & Maintenance Instructions

Coal Ash Fusion Furnace

CAF 16/38

This manual is for the guidance of operators of the above Carbolite Gero product and should be read before the furnace is connected to the electricity supply.

CONTENTS

Section		page
1.0	Symbols & Warnings	2
2.0	Installation	4
3.0	Operation	5
4.0	Maintenance	6
5.0	Repairs & Replacements	8
6.0	Fault Analysis	10
7.0	Circuit Diagrams	11
8.0	Fuses & Power Settings	12
9.0	Specifications	12

**Manuals are supplied separately for the furnace controller
(and overtemperature controller when fitted).**

1.0 SYMBOLS & WARNINGS

1.1 Switches and Lights



Instrument switch: when the instrument switch is operated the temperature control circuit is energised.



Heat Switch: the switch disconnects power to the heating elements; unless this switch is off there is a danger of electric shock when inserting objects into the furnace



Heat Light: the adjacent light glows or flashes to indicate that power is being supplied to the elements

1.2 Warning Symbols

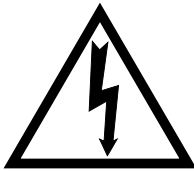

DANGER of electrical shock– read any warning printed by this symbol.



DANGER – hot surface. Read any warning printed by this symbol.
WARNING: all surfaces of a furnace may be hot.



DANGER – read any warning printed by this symbol.



DANGER – read any warning printed by this symbol.

1.3 Hydrogen and Carbon Dioxide Warning

H₂ can form explosive gas mixtures, take precautions to avoid leakage of H₂. H₂ and CO₂ can react to form CO. See section 1.4: Carbon Monoxide Warning.

Carbon dioxide (CO₂) is a colourless, odourless and tasteless gas that is an asphyxiant. Rapid unconsciousness occurs at levels above 11%, levels of 20 - 30% are immediately hazardous to life.

Information extracted from Croner Publications Ltd. Substances Hazardous To Health.

To minimise the risks associated with CO₂ it is most important that the furnace is installed and operated in accordance with this instruction manual. If the furnace operator experiences any of the effects listed above, the furnace must be isolated from the gas and electricity supplies immediately and expert advice sought. For safety guidelines seek the gas manufacturers advice.



1.4 Carbon Monoxide Warning

Carbon monoxide is a product of reaction of H₂ and CO₂.

Carbon monoxide (CO) is a colourless, odourless, tasteless and inflammable gas which is acutely toxic. CO is introduced into the blood stream through the lungs and binds with the haemoglobin preventing it from carrying oxygen around the body. This can result in rapid damage to body tissues due to oxygen starvation. Since CO is an accumulating toxin it can be dangerous even when present in quite low concentrations over long periods of time.

Individuals vary considerably in their reactions to concentrations of toxic gases; table 1 shows the typical effects of cumulative CO exposure.

Information extracted from Guidance Note EH43 (1996) from the Health and Safety Executive.

To minimise the risks associated with CO it is most important that the furnace is installed and operated in accordance with this instruction manual. If the furnace operator experiences any of the effects listed above, the furnace must be isolated from the gas and electricity supplies immediately and expert advice sought. For safety guidelines seek the gas manufacturers advice.



Table 1. Carbon monoxide in air:

Parts per million	Effect.
50	Recommended Exposure Limit (8 hours time weighted average concentration).
200	Headache after about 7 hours if resting or after 2 hours exertion.
400	Headache with discomfort with possibility of collapse after 2 hours at rest or 45 minutes exertion.
1200	Palpitations after 30 minutes at rest or 10 minutes exertion.
2000	Unconscious after 30 minutes at rest or up to 10 minutes exertion.

For further information refer to:

- *Guidance Note EH43 (1996) from the Health and Safety Executive. ISBN 0 11 883597 1*
- *EH40/97 Occupational Exposure Limits 1997. ISBN 0 7176 1315 1*

2.0 INSTALLATION

2.1 Unpacking & Handling

When unpacking or moving the furnace always lift it by its base, not by any protruding fittings. Use two people to carry the furnace where possible. Remove all packing material.

NOTE: This product contains **Refractory Ceramic Fibre** (better described as **Alumino Silicate Wool**) for precautions and advice in handling this material see the ‘Repairs and Replacements’ section.

2.2 Siting

Place the furnace in a well ventilated room: positive ventilation is recommended. See the warnings in sections 1.3 and 1.4.

Site the furnace away from other sources of heat, on a surface which is resistant to accidental spillage of hot materials. Do not mount the furnace on an inflammable surface.

Ensure that there is free space around the furnace. Do not obstruct any of the vents in the control section: they are needed to keep the controls cool.

Ensure that the furnace is placed in such a way that it can be quickly switched off or disconnected from the electrical supply - see below.

2.3 Fitting the Heating Elements

The Silicon Carbide elements are VERY FRAGILE and are packed separately. Fit them according to the instructions in section 5.6.

2.4 Telescope

The telescope and its trunion arm are packed separately, and should be attached to the front of the furnace.

2.5 Electrical Connections

Connection by a qualified electrician is recommended.

The furnace requires a single-phase A.C. supply with earth (ground). The supply may be Live to Neutral non-reversible, Live to Neutral with reversible plug, or Live to Live.

Check the furnace rating label before connection. The supply voltage should agree with the voltage on the label, and the supply capacity should be sufficient for the amperage on the label.

The supply should be fused at the next size equal to or higher than the amperage on the label. See section 8.1 for fuse rating data. Internal supply fuses are only fitted if a supply cable is fitted; customer fusing is essential.

Furnace with supply cable: either wire directly to an isolator or fit with a line plug.

Furnace without supply cable: a permanent connection to a fused and isolated supply should be made to the internal terminals after temporary removal of the furnace back panel.

Connection by line plug: the plug should be within reach of the operator, and should be quickly removable. Connection to isolating switch: this should operate on both conductors (single phase) or on all live conductors (three phase), and should be within reach of the operator.

Single phase: connect the supply as follows:

Cable colour	Terminal label	supply type	
		Live-Neutral	Reversible or Live-Live
Brown	L	to live	to either power conductor
Blue	N	to neutral	to the other power conductor
Green/Yellow	PE	to earth (ground)	to earth (ground)

The supply **MUST** incorporate an earth (ground).

2.6 Gas Connections

The furnace is fitted with two flowmeters, one for Carbon Dioxide (CO₂) on the left, and the other for Hydrogen (H₂) on the right. The output from the flowmeters is mixed and taken directly to the work tube through a connection at the front.



There are no valves or non-return devices on this furnace. Regulated supplies of CO₂ and H₂ must be connected in a safe manner to ensure that all gas flow is through the work tube. The gas supply pressure required is 4 psi (0.276 bar) and must not exceed this.



At the back of the furnace is a copper exhaust vent pipe. The exhaust fumes are dangerous (see Carbon Monoxide warning, section 1.4). The exhaust must be properly vented into a suitable duct or fume cupboard, and must not be allowed to contaminate the atmosphere of the room in which the furnace is sited.

3.0 OPERATION

The instructions for operating the temperature controller are given in a separate manual.

If the furnace is fitted with a time switch, see also the supplementary manual MS03.

3.1 Basic Furnace Operation

The furnace is fitted with an instrument switch. The switch cuts off power to the control circuit.

Connect the furnace to the electrical supply.

Operate the instrument switch to activate the temperature controller. The controller becomes illuminated and goes through a short test cycle. Adjust the temperature controller (see controller manual).

Overtemperature option only. If the overtemperature controller has not yet been set as required, set it and activate it according to the instructions in the appropriate manual.

Unless a time switch is fitted and is off, the furnace starts to heat up. The Heat light(s) glow steadily at first and then flash as the furnace approaches the desired temperature or a program setpoint.

Unless a time switch is fitted and is off, the furnace starts to heat up. The Heat light(s) glow steadily at first and then flash as the furnace approaches the desired temperature or a program setpoint.

Overtemperature option only. If the overtemperature trip operates then an indicator in the overtemperature controller flashes, and the heating elements are isolated. Find and correct the cause before resetting the overtemperature controller according the instructions supplied.

To turn the furnace off, set the Instrument switch to it's off position; the controller display will go blank. If the furnace is to be left off unattended, isolate it the electrical supply.

3.2 Setting up for Coal Ash Fusion Test

The CAF 16/38 is designed to be compatible with the following:

BS 1016 : Part 113 : 1995 ISO 540 : 1995 Methods for Analysis and Testing of Coal and Coke. Part 113. Determination of Ash Fusibility.

The test procedure is entirely manual and under user control. An example of the procedure is as follows.

Heat the furnace up to its starting temperature.

Open the furnace door and swing it clear of the work tube to allow access. Load the sample into the work tube. The sample

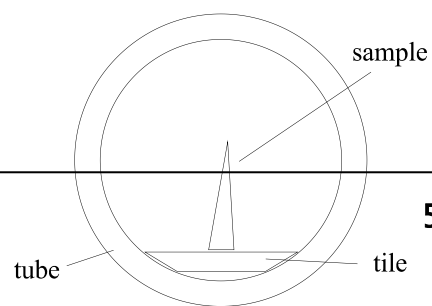

tile with one or two samples on it should be placed centrally along the length of the work tube.

Set the ramp rate on the controller, if required, to limit the heating rate. A rate of 7°C/min is suggested and is factory preset.

Set the controller to heat the furnace up to the final temperature. Swing the telescope into place to allow observation of the sample.

Watch the sample and record the temperature at which it fuses. Make all other records such as time and temperature as required by your own organisation.

Switch off and allow to cool down; or set the setpoint to zero or to the normal test starting temperature, so that the temperature is displayed as the furnace cools.

Note: Do not operate the furnace at temperatures above 815°C (1499°F) with the door open. The furnace door must not be left open longer than is necessary to load and unload samples from the work tube.

Sample tiles can be obtained from Carbolite Gero. A brass mould to assist with forming samples is supplied with the furnace.

3.3 General Operating Advice

Heating element life is shortened by use at temperatures close to maximum. Do not leave the furnace at high temperature when not required. The maximum temperature is shown on the furnace rating label and on the back page of this manual.

Light weight ceramic fibre insulation can easily be marked by accidental contact. Some fine cracks may be visible on the surface of the insulation, or may develop in the surface of the chamber due to the progressive shrinkage of the insulation materials. Cracks are not usually detrimental to the functioning or the safety of the furnace.

3.4 Tube Life

The following applies if the furnace is used for a purpose other than its standard application.

A work tube may be cracked if workpieces are inserted too quickly or at temperatures below 900°C (when the tube is more brittle). Large pieces should also be heated slowly to ensure that large temperature differences do not arise.

Poor thermal contact should be encouraged between the workpiece and the tube; crucibles or boats should be of low thermal mass and should have feet to reduce the contact with the tube.

Avoid metal directly touching the work tube - see the safety warning below.

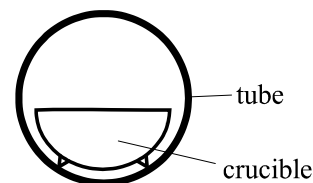

avoidance of thermal contact

3.5 Operator Safety

 The ceramic materials used in furnace manufacture become electrically conductive to some extent at high temperatures. DO NOT use any conductive tools within the work tube without isolating it.

Warning: Do not use the furnace if the work tube is cracked as there is a risk of exposure to carbon monoxide gas. See section 1.4: Carbon Monoxide Warning.

4.0 MAINTENANCE

4.1 General Maintenance

No routine maintenance is required other than the occasional replacement of consumable items.

The furnace outer surface may be cleaned with a damp cloth. Do not allow water to enter the interior of the case or chamber. Do not clean with organic solvents.

4.2 Element Ageing

Silicon carbide elements gradually increase in resistance with use: a process known as ageing. Their heating power reduces correspondingly, and eventually the elements must be replaced.

Once the heating elements have been in use for some time, they should only be replaced as a set. Single elements may be replaced (in the case of breakage, for example) when the elements are reasonably new.

4.3 Calibration

After prolonged use the controller and/or thermocouple could require recalibration. This would be important for processes which require accurate temperature readings or which use the furnace close to its maximum temperature. A quick check using an independent thermocouple and temperature indicator should be made from time to time to determine whether full calibration is required. Carbolite Gero can supply these items.

Depending on the controller, the controller manual may contain calibration instructions.

4.4 After Sales Service

Carbolite Gero's service division (Carbolite Gero Service) has a team of Service Engineers capable of repair, calibration and preventive maintenance of furnace and oven products at our customers' premises throughout the world. We also sell spares by mail order. A telephone call or fax often enables a fault to be diagnosed and the necessary spare part despatched.

Each furnace has its own record card at Carbolite Gero. In all correspondence please quote the serial number, model type and voltage given on the rating label of the furnace. The serial number and model type are also given on the front of this booklet when supplied with a furnace.

To contact Carbolite Gero Service or Carbolite Gero see the back page of this manual.

4.5 Recommended Spares Kits

Carbolite Gero can supply individual spares, or a kit of the items most likely to be required. Ordering a kit in advance can save time in the event of a breakdown. Each kit comprises a thermocouple and sheath, a solid state relay, a set of heating elements and a set of clips and braids. When ordering spares please quote the model details as requested above.

5.0 REPAIRS & REPLACEMENTS

5.1 Safety Warning – Disconnection from Supply

Always ensure that the furnace is disconnected from the supply before repair work is carried out. Caution : Double pole/neutral fusing may be used in this product.

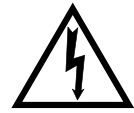

5.2 Safety Note - Refractory Fibrous Insulation

Insulation made from High Temperature Insulation Wool

Refractory Ceramic Fibre, (better described as Alumino Silicate Wool) (ASW)



This product contains **alumino silicate wool products** in its thermal insulation. These materials may be in the form of blanket or felt, formed board or shapes, mineral wool slab or loose fill wool.

Whilst there is no evidence of any long term health hazards, we strongly recommend that safety precautions are taken whenever the materials are handled.

Exposure to fibrous dust may cause respiratory disease.

When handling the material always use an approved respiratory protection equipment (RPE-i.e. FFP3), eye protection, gloves and long sleeved clothing.

Avoid breaking up waste material. Dispose of waste in sealed containers.

After handling rinse exposed skin with water before washing gently with soap (not detergent). Wash work clothing separately.

Before commencing any major repairs we recommend reference to the European Association representing the High Temperature Insulation Wool industry (www.ecfia.eu)

We can provide further information on request. Alternatively our service division can quote for any repairs to be carried out at your premises or ours.

5.3 Temperature Controller Replacement

201. This controller is fitted to the back of the control panel; in many models this can be separated from the base by removal of two screws.



Before handling the controller: **wear an anti-static wrist strap** or otherwise avoid any possibility of damage to the unit by static electricity.

Refer to the detailed instructions supplied with the replacement controller.

2132, 2416, 2408 etc. Ease apart the two lugs at the side; grip the instrument and withdraw it from its sleeve; push in the replacement.

5.4 Solid-state Relay Replacement

Disconnect the furnace from the supply and remove the panel at nearest to the supply cable.

Make a note how the wires are connected to the solid state relay, and disconnect them.

Remove the solid state relay from the base panel or aluminium plate.

Replace and reconnect the solid state relay ensuring that the heat-conducting thermal pad is sandwiched between the relay and the base panel or aluminium plate. Alternatively a thin layer of white, heat-conducting silicon paste may be applied between the new relay and the plate.

The new solid state relay contains a built-in MOV which protects it from short periods of excess voltage. If the old relay had a separate disc-shaped "MOV" connected between the high voltage terminals of the old relay, discard the old MOV.

Replace the removed panel.

5.5 Thermocouple Replacement

Disconnect the furnace from the supply, and remove the thermocouple cover fixed to the back panel.

Make a note of the thermocouple connections. The negative leg of the thermocouple is marked blue. Compensating cable colour codings are:

<i>negative</i>	<i>positive (type R)</i>
white	orange

Disconnect the thermocouple from its terminal block; retain any porcelain spacers.

Withdraw the thermocouple from its sheath and remove any broken bits of thermocouple.

Re-assemble with a new thermocouple observing the colour coding.

5.6 Element Fitting and Replacement

Disconnect the furnace from the electrical supply.

Remove the complete front panel. Remove the thermocouple cover and the square plate from the back panel.

The elements are expensive and fragile, and can be damaged by contamination: handle them with care and keep them clean.

Replacements only: make a note of the actual braid and cable connections to the elements.

Disconnect the clips with the special tool provided (or with finger pressure, depending on the type of clips supplied), lift off the braids and carefully withdraw each element. See fig. 5.

Carefully insert the new elements into the furnace.

Attach the connection braids according to the note made above or to the appropriate diagram, fig. 6. Use the special tool (or finger pressure) to fit the clips. Take care that adjacent clips do not touch each other.

Replace the furnace end panels and connect the furnace to the supply.

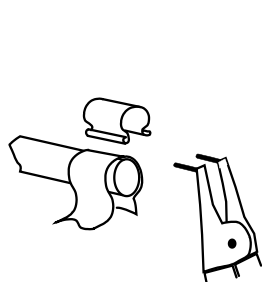

Fig.5. - Use of Clip Tool

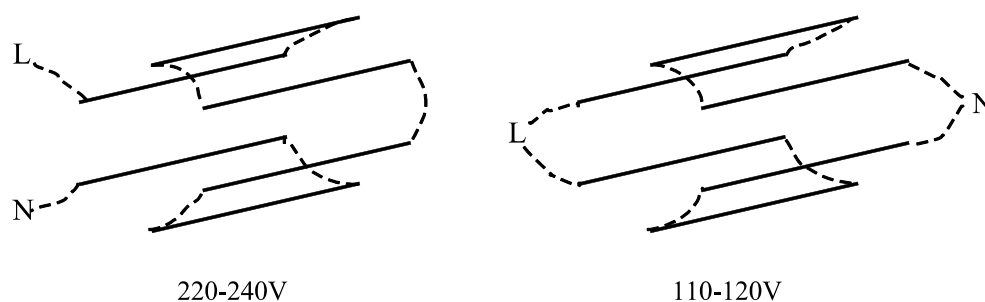

Fig.6. - Element Connections

5.7 Fuse Replacement

Fuses are marked on the circuit diagram (section 7.0) with type codes, e.g. F1, F2. A list of the correct fuses is given in section 8.1. *Depending on model and voltage, the different fuse types may or may not be fitted.*

If any fuse has failed, it is advisable for an electrician to check the internal circuits.

Replace any failed fuses with the correct type. For safety reasons do not fit larger capacity fuses without first consulting Carbolite Gero.

The fuses are near the cable entry point, and access is by removal of a panel.

6.0 FAULT ANALYSIS

A. Furnace Does Not Heat Up

1. The **HEAT** light is **ON**
 - The heating element has failed
 - Check also that the SSR is working correctly
2. The **HEAT** light is **OFF**
 - The controller shows a **very high temperature** or a code such as S.br
 - The thermocouple has broken or has a wiring fault
 - The door switch(es) (if fitted) may be faulty or need adjustment
 - The contactor (if fitted) may be faulty
 - The SSR could be failing to switch on due to internal failure, faulty logic wiring from the controller, or faulty controller
 - There are no lights glowing on the controller
 - Check the supply fuses and any fuses in the furnace control compartment
 - The controller may be faulty or not receiving a supply due to a faulty switch or a wiring fault

B. Furnace Overheats

1. The **HEAT** light goes **OFF** with the instrument switch
 - The controller shows a **very high** temperature
 - The controller is faulty
 - The thermocouple may have been shorted out or may have been moved out of the heating chamber
 - The thermocouple may be mounted the wrong way round
 - The controller may be faulty
2. The **HEAT** light **does not go off** with the instrument switch
 - The SSR has failed "ON"
 - Check for an accidental wiring fault which could have overloaded the SSR

7.0 CIRCUIT DIAGRAMS

7.1 Without Overtemperature Control

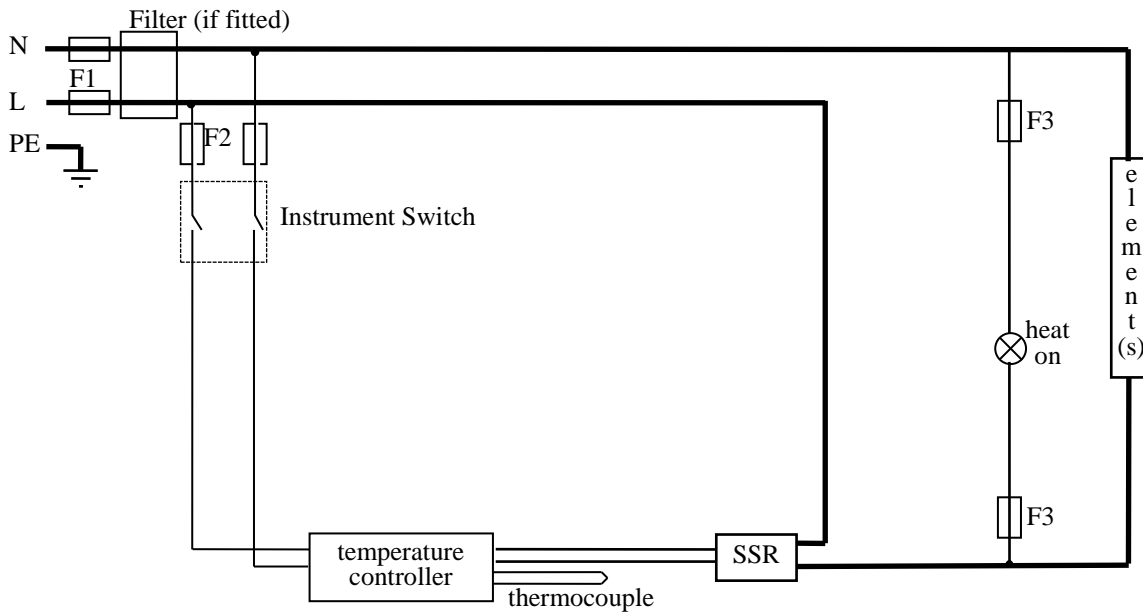

7.2 With Overtemperature Control

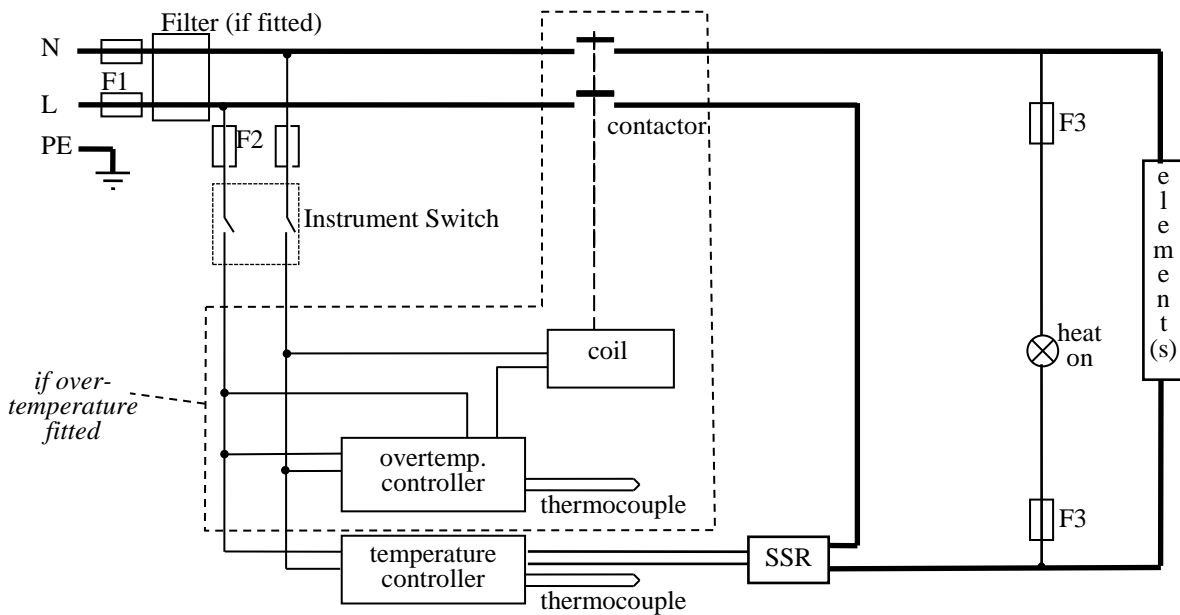

8.0 FUSES & POWER SETTINGS

8.1 Fuses

F1-F3: Refer to the circuit diagrams.

<i>F1</i>	Internal supply fuses	Fitted if supply cable fitted. Fitted on board to some types of EMC filter.	on-board and up to 16 Amps: 32mm x 6mm type F other: GEC Safeclip
<i>F2</i>	Auxiliary circuit fuses	Fitted on board to some types of EMC filter. May be omitted up to 25Amp/phase supply rating.	2 Amps glass type F On board: 20mm x 5mm Other: 32mm x 6mm
<i>F3</i>	Heat Light fuses	May be omitted up to 25 Amp/phase supply rating.	2 Amps glass type F 32mm x 6mm
	Customer fuses	Required if no supply cable fitted. Recommended if cable fitted.	See rating label for amperage; see table below for fuse rating.

Model	phases	Volts	Supply Fuse Rating	Volts	Supply Fuse Rating (type)
CAF 16/38	1-phase	220-240	25A	110-120	50A

8.2 Power Settings

The power limit parameter OP.Hi is set to 100%.

9.0 SPECIFICATIONS

Carbolite Gero reserves the right to change specifications without notice.

9.1 Models Covered by this Manual

MODEL	Max. Temp. (°C)	Max. Power (kW)	Internal Bore (mm)	Net Weight (kg)
<i>Coal Ash Fusion Testing Furnace</i>				
CAF 16/38	1600°C	4.5	38mm	67

9.2 Environment

The furnaces contain electrical parts and should be stored and used in indoor conditions as follows:

temperature: 5°C - 40°C

relative humidity: maximum 80% up to 31°C decreasing linearly to 50% at 40°C

The products covered in this manual are only a small part of the wide range of ovens, chamber furnaces and tube furnaces manufactured by Carbolite Gero for laboratory and industrial use. For further details of our standard or custom built products please contact us at the address below, or ask your nearest stockist.

For preventive maintenance, repair and calibration of all Furnace and Oven products, please contact:

Carbolite Gero Service

Telephone: +44 (0)1433 624242

Fax: +44 (0)1433 624243

Email: ServiceUK@carbolite-gero.com

CARBOLITE[®]
IGERO 30-3000°C

Carbolite Gero Limited, Parsons Lane, Hope,
Hope Valley, S33 6RB, England.

Telephone: +44 (0)1433 620011

Fax: +44 (0)1433 621198

E-mail: info@carbolite-gero.com