



ST-48 Combustible/Toxic Gas Monitor

Product Summary

The PureAire ST-48 Combustible/Toxic Gas Monitor is ideal for facilities that require continuous monitoring of toxic or combustible gases in hazardous areas. The enclosure is specifically designed to prevent an explosion. The monitor is best suited for environments such as refineries, wastewater treatment, parking garages, laboratories, pharmaceutical, research and development, natural gas locations, and the oil and gas industry and any other locations where toxic or combustible gases are present. Operator interface is via a menu driven magnetic keypad allowing full access without opening the enclosure. The monitor is housed in a NEMA 7 explosion proof enclosure suitable for Class 1, Division 1 and 2, Groups A, B, C, and D.

Industries That Need This Product

- *Refineries*
- *Natural Gas Operations*
- *Laboratories*
- *Pharmaceutical*
- *Parking Garages*
- *Oil and Gas*
- *Wastewater Treatment*

FEATURES

- **Non-Intrusive one-man calibration**
- **Explosion-Proof enclosure Cl. 1, Div. 1 & 2, Grps. A, B, C, D**
- **6" Back-lit LCD Display with Bar Graph and Trending**
- **4-20 mA Output**
- **User Adjustable Dual Alarm Relays**
- **RS-485 Modbus Optional**
- **NRTL/ATEX Certifications**

Why Choose PureAire?

PureAire Monitoring Systems, Inc. is an industry leader in oxygen monitoring and gas detection. For over 20 years, we have dedicated ourselves to the safety of our clients, and the customers they serve, by manufacturing monitors that are long-lasting, accurate, and reliable. PureAire takes pride in providing exceptional customer service along with 24/7 availability to our technical service department.

Why an ST-48 Combustible Gas Monitor?

The PureAire ST-48 Combustible/Toxic Gas Monitor is designed for continuous monitoring where toxic or combustible gases are used, and the risk of an explosion, or a leak pose a hazard to personnel.

Set Up

Secure the ST-48 monitor to the wall so the display is visible, and connect the monitor to the power source. The ST-48 will begin sampling gas levels after a brief startup period. Gas levels are displayed clearly on the screen for easy access and visibility.

Top Advantages of ST-48 Combustible/Toxic Gas Monitor



Gas Detector Alarms

PureAire's ST-48 Combustible/Toxic Gas Monitor comes with 2 adjustable alarm set-points that can connect to a horn/strobe, exhaust fans, 8 channel controller, remote display, or into building systems. Alarm signals also can tie into automatic shut-off valves when gas levels reach an unsafe threshold.



Easy To Use

The ST-48 Combustible/Toxic Gas Monitor provides constant monitoring with little to no adjustments, saving you time and money while allowing the monitor to operate seamlessly.

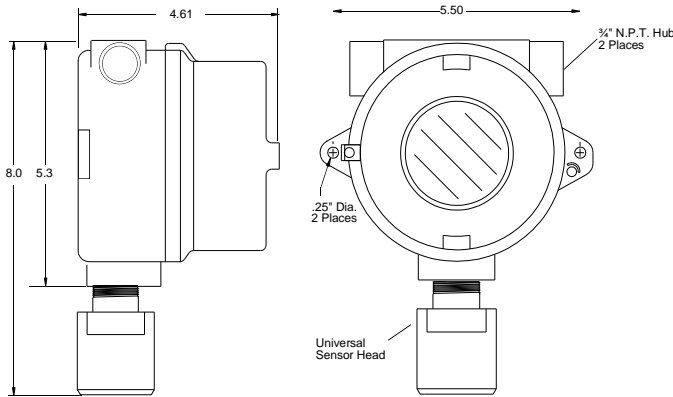

Optional Gases

Item#	Description
95107	ST-48 Carbon Monoxide 0-100ppm
95108	ST-48 Combo CO/Methane 0-100ppm/0-100% LEL
95114	ST-48 Isopropyl Alcohol 0-1,000ppm
95119	ST-48 Butyl Acetate 0-100% LEL
95122	ST-48 Hydrogen Sulfide 0-30ppm
95124	ST-48 Ethane 0-100% LEL
95125	ST-48 Ethanol 0-100% LEL
95126	ST-48 Ethylene Oxide 0-100% LEL
95130	ST-48 Xylene 0-100% LEL
95131	ST-48 Gasoline 0-100% LEL
95132	ST-48 Hydrogen 0-100% LEL
95133	ST-48 Propane 0-100%LEL
95134	ST-48 Isobutyl 0-100% LEL
95135	ST-48 Methane 0-100% LEL
95136	ST-48 Kerosene 0-100% LEL
95137	ST-48 Dodecane 0-100% LEL
95138	ST-48 Ethylene 0-100% LEL
95139	ST-48 Ethyl Acetate 0-100% LEL
95140	ST-48 Diethyl Ether 0-100% LEL
95141	ST-48 Toluene 0-100% LEL
95142	ST-48 Tert Butanol 0-100% LEL
95143	ST-48 Cyclohexane 0-100% LEL
95144	ST-48 Acetonitrile 0-100% LEL
95145	ST-48 Tetrahydrofuran 0-100% LEL
95146	ST-48 Methanol 0-100% LEL
95147	ST-48 Isopropanol 0-100% LEL
95148	ST-48 Dichloromethane 0-100% LEL
95149	ST-48 Dimethylformamide 0-100% LEL
95161	ST-48 Acetylene 0-100% LEL
95162	ST-48 Hexane 0-100% LEL
95163	ST-48 Acetone 0-100% LEL
95164	ST-48 Heptane 0-100% LEL
95165	ST-48 Hydrogen Sulfide 0-200ppm
95166	ST-48 Hydrogen Sulfide 0-500ppm
95169	ST-48 Acetic Acid 0-100% LEL
95170	ST-48 Butane 0-100% LEL

Top Accessories



8 Channel Controller for Gas Monitors

ITEM #: 99196



Remote Digital Display

ITEM #: 99091



Red Horn/Strobe

ITEM #: 42002



1-888-788-8050

info@pureaire.net
pureairemonitoring.com

1140 Ensell Road
Lake Zurich, IL 60047
1-847-726-6000