

photometrics®
PRIME
95B 25MM

Large Field of View BSI Scientific CMOS

Discovery depends on every photon

The Prime 95B 25mm delivers an extremely large imaging area and combines this with the near-perfect sensitivity of a Backside Illuminated (BSI) Scientific CMOS sensor. The Prime 95B 25mm sensor converts up to 95% of incident photons into measurable signal, and provides an unmatched 25mm field of view. The Prime 95B 25mm is optimally positioned to maximize detection and imaging throughput when mounted on the Nikon ECLIPSE Ti2 microscope.

The extreme sensitivity not only allows fainter signals to be detected, it provides the flexibility to increase frame rates, or turn down the excitation intensity to reduce cellular photo-damage. The Prime 95B 25mm improves the field of view and maintains the high frame rates and extremely low read noise that has made sCMOS so popular for live-cell imaging.

- ▶ 95% Quantum Efficiency
- ▶ 25mm Field of View (1608x1608)
- ▶ 1.6e- Read Noise (median)
- ▶ 30fps @ 16-bit / 60 fps @ 12-bit

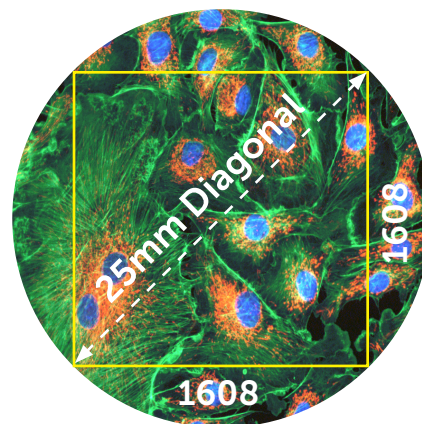

Features	Advantages
High Quantum Efficiency 95% Peak QE	Maximizes ability to detect weak signals, enables short exposure times for high frame rates, minimizes phototoxicity across a wide range of wavelengths
Large 25mm Field of View	Maximize imaging area and increase throughput
Large 11µm Pixel Size	Maximize light collection while maintaining proper spatial sampling
Extremely Low Read Noise	Maximize your ability to detect faint fluorescence
Fast Frame Rates	Capture highly dynamic events with high temporal resolution
Enhanced Dynamic Range	Measure both bright and dim signal levels within the same image 50,000:1 Dynamic Range (94 dB)
Multiple Expose Out Triggering	Control up to four light sources for multi-wavelength acquisitions
SMART Streaming	Faster acquisition rates with variable exposures, ideal for multi-probed live cell imaging Compatible with Multiple Expose Out Triggering



2.6 Megapixel BSI CMOS Sensor

- Backside Illuminated Sensor
- 1.6e- Read Noise (Median)
- >95% peak QE
- 80,000e- full well
- 11 x 11µm pixels
- 25mm diagonal

Easily Mounted and Secured

- C-Mount
- Two ¼"-20 mounting holes per side

Convenient Interfaces

- 16-bit Data
 - 30 fps
- 12-bit Data
 - 60 fps

Multiple Cooling Options

- Forced Air Cooling
 - -20°C Cooling
 - Selectable Fan Speed
- Liquid Cooling
 - -25°C Cooling
 - Leak-proof, quick-disconnect ports

Advanced Application Triggers

- Effective Global Shutter
- Up to four selectable expose-out lines



Specifications	Camera Performance
Sensor	GPixel GSense 400 BSI CMOS Gen IV, Grade 1 in imaging area
Active Array Size	1608 x 1608 (2.58 Megapixel)
Pixel Area	11µm x 11µm (121µm ²)
Sensor Area	17.69mm x 17.69mm 25mm diagonal
Peak QE%	>95%
Read Noise	1.6 e ⁻ (Median) 1.8e ⁻ (RMS)
Full-Well Capacity	80,000e ⁻
Dynamic Range	50,000:1
Bit Depth	16-bit, 12-bit
Readout Mode	Rolling Shutter Effective Global Shutter
Binning	2x2 (on FPGA)
Linearity	>99.5%

Cooling Performance	Sensor Temperature	Dark Current
Air Cooled	-20°C @ 25°C Ambient	0.55e ⁻ /pixel/second
Liquid Cooled	-25°C @ 25°C Ambient	0.3e ⁻ /pixel/second

Specification	Camera Performance
Digital Interface	PCIe
Lens Interface	F-Mount
Mounting Points	2x 1/4" -20 mounting points per side to prevent rotation
Liquid Cooling	Quick Disconnect Ports

Triggering Mode	Function
Input Trigger Modes	Trigger First: Sequence triggered on first rising edge Edge: Each frame triggered on rising edge SMART Streaming: Fast iteration through multiple exposure times
Output Trigger Modes	First Row: Expose signal is high while first row is acquiring data Any Row: Expose signal is high while any row is acquiring data All Rows: Effective Global Shutter – Expose signal is high when all rows are acquiring data
Output Trigger Signals	Expose Out (up to four signals), Read Out, Trigger Ready

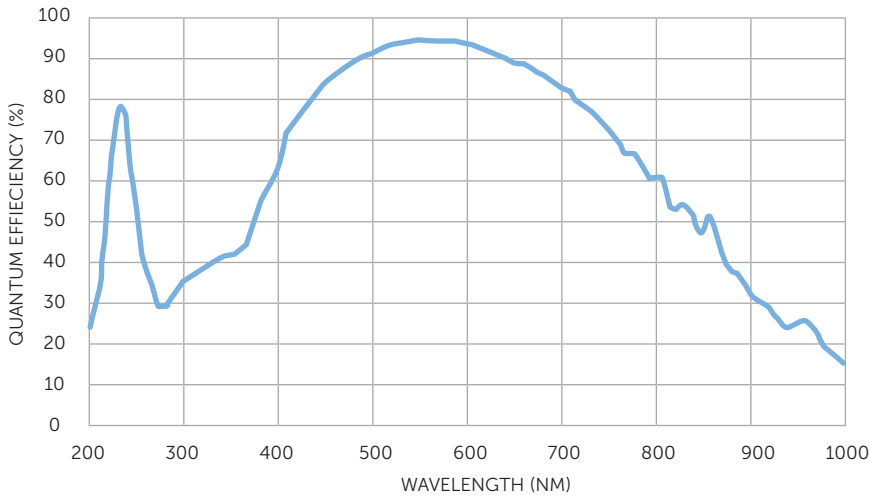

Frame Rate (PCIe interface)		
Array Size	16-bit	12-bit
1608 x 1608	30	60
1608 x 1200	41	82
1608 x 512	96	192
1608 x 256	192	384
1608 x 128	384	736

Accessories (Included)

- PCIe Card/Cable
- Power Supply
- USB 3.0 Cable
- Manuals and QuickStart Guide
- Trigger Cables
- Performance and Gain Calibration Test Data

Accessories (Additional)

- Liquid Circulator
- Liquid Cooling Tubes

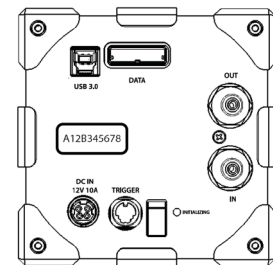
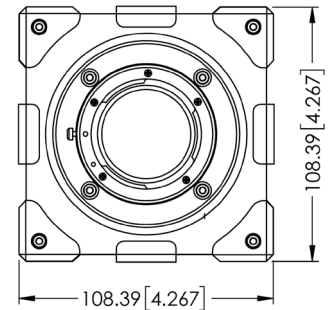
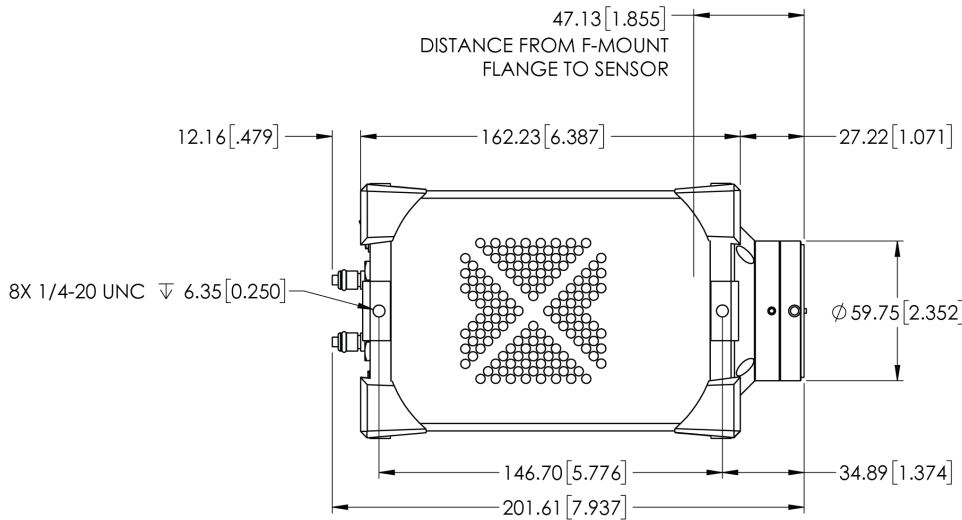

Teledyne Photometrics is a registered trademark.
 Prime 95B 25mm is a trademark of Teledyne Photometrics.
 All other brand and product names are the trademarks of their respective owners.

Specifications in this datasheet are subject to change.
 Refer to the Teledyne Photometrics website for most current specifications.

