



FEATURES

- Class 1, Group B, C, and D, Class 2, Group E, F, and G
- Long Life LEL Catalytic Sensor
- Two-Alarm setpoints Relays
- 3 year warranty
- Digital display, and 4-20mA analog output
- Wall mounting bracket

Air Check Explosion Proof Combustible Gas Monitor

ITEM #: EX-2300

Product Summary

The Air Check Explosion Proof Combustible Gas Monitor is ideal for facilities that require continuous monitoring of toxic and corrosive gases in hazardous areas. The enclosure is specifically designed to prevent an explosion. The monitor is well suited for environments such as power plants, refineries, natural gas locations, and the oil and gas industry where combustible, toxic gases are present. The monitor is housed in a NEMA 4 explosion proof enclosure suitable for Class 1, Group B, C, and D, Class 2, Group E, F, and G. PureAire's durable, long-life LEL catalytic sensor will last 4-5 years in a normal environment without needing to be replaced.

Facilities That Need This Product

- Refineries
- Power Plants
- Natural Gas Operations
- Laboratories
- Wastewater Treatment
- Oil and Gas
- Battery storage
- Paint Booths

Why Choose PureAire?

PureAire Monitoring Systems, Inc. is an industry leader in oxygen monitoring and gas detection. For over 20 years, we have dedicated ourselves to the safety of our clients, and the customers they serve, by manufacturing monitors that are long-lasting, accurate, and reliable. PureAire takes pride in providing exceptional customer service along with 24/7 availability to our technical service department.

Why an LEL Explosion Proof Combustible Gas Monitor?

The Air Check LEL Combustible Gas Monitor is designed for continuous monitoring where toxic, combustible gases are used, and the risk of an explosion pose a hazard to personnel.

What Gases Can Be Detected with an LEL Combustible Explosion Proof Gas Monitor?

PureAire's LEL combustible gas monitor continuously measures levels of toxic, combustible gases such as acetylene, carbon monoxide, hydrogen, methane, propane, ethane, ethylene, natural gas, among others.

Set Up

The Air Check EX Combustible Gas Monitor incorporates a power up delay that holds the analog output at 4mA for one minute after power is applied. This allows the sensor to stabilize and reduces the possibility of triggering an erroneous alarm. The LCD continuously displays the gas concentration value.

Top Advantages of Combustible Gas Monitor



Gas Detector Alarms

PureAire's LEL Monitor comes with 2 adjustable alarm set-points that can connect to a horn/strobe, exhaust fans, 8 channel controller, remote display, or into building systems. Alarm signals also can tie into automatic shut-off valves when gas levels reach an OSHA action level threshold.



Easy To Use

The EX-2300 Combustible Gas Monitor provides constant monitoring with little to no adjustments, saving you time and money while allowing the monitor to operate seamlessly.

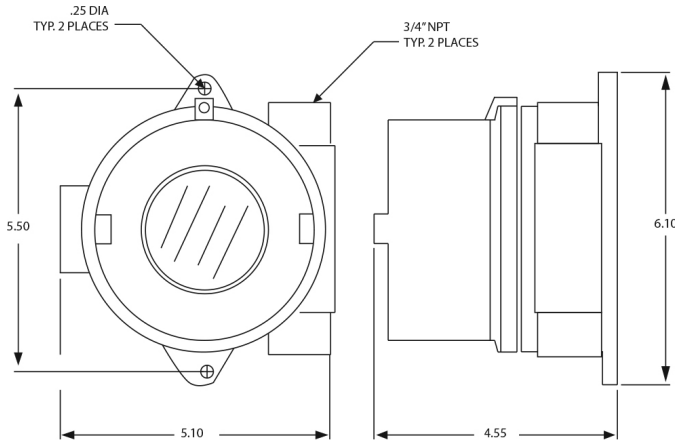

Ordering Information

Item#	Description
95105	Air Check EX Methane Gas Monitor
95108	Air Check EX CO/LEL Gas Monitor
95110	Air Check EX Hydrogen Gas Monitor
95118	Air Check EX Ethanol Gas Monitor
95120	Air Check EX Propane Gas Monitor
95160	Air Check EX Acetylene Gas Monitor
95124	Air Check EX Ethane LEL
95121	Air Check EX Butane LEL
95114	Air Check EX IPA, Isopropyl Alcohol
95119	Air Check EX Butyl Acetate LEL
95130	Air Check EX Xylene LEL
95131	Air Check EX Gasoline LEL

Top Accessories



8 Channel Controller for Gas Monitors

ITEM #: 99058



Remote Digital Display

ITEM #: 99091



Red Horn/Strobe 24VDC

ITEM #: 42002



1-888-788-8050

info@pureaire.net
pureairemonitoring.com

1140 Ensell Road
Lake Zurich, IL 60047
1-847-726-6000