

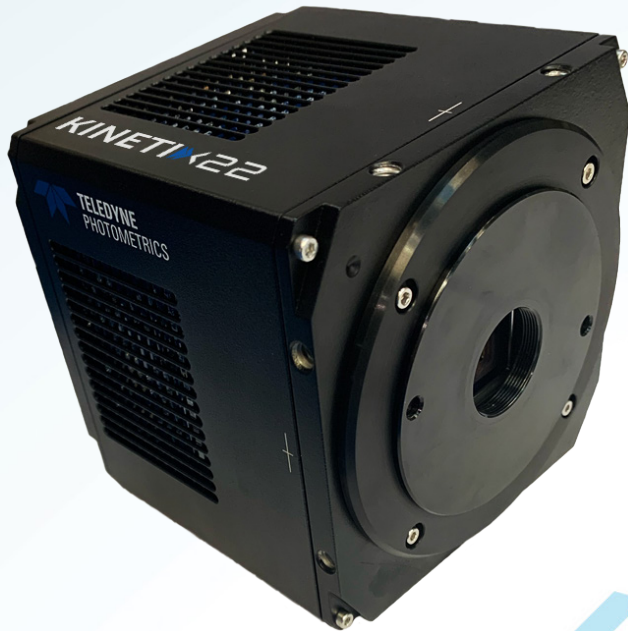

TELEDYNE PHOTOMETRICS
Everywhereyoulook™

KINETIX22

High Speed, Back-Illuminated sCMOS



22 mm Field Of View
5.76 Megapixel 2400x2400
6.5 μm Pixels
498 Frames Per Second
95% Quantum Efficiency
0.7 e- Read noise

Specifications	Camera Performance
Sensor	Teledyne Photometrics Kinetix Sensor
Active Array Size	2400 x 2400 (5.76 Megapixel)
Pixel Area	6.5µm x 6.5µm (42.25 µm ²)
Sensor Area	15.6 mm x 15.6 mm 22 mm diagonal
Peak QE%	>95%
Readout Mode	Rolling Shutter Effective Global Shutter Programmable Scan Mode
Digital Binning	Symmetrical and Asymmetrical Binning up to 4x4 pixels
Linearity	>99%
Cooling Options	Air Cooled Liquid Cooled

Camera Modes				
Specifications	Dynamic Range	Speed	Sensitivity (CMS)	Sub-Electron (8x CMS)
Bit-Depth	16-bit	8-bit	12-bit	16-bit
Full Frame Rate	83 fps	498 fps	88 fps	5.2 fps
Read Noise	1.6e ⁻	2.0e ⁻	1.2e ⁻	0.7e ⁻
Cooling	0° C	0° C	0° C	0° C
Line Time	5 µsec/line	0.836 µsec/line	4.71 µsec/line	80.12 µsec/line
Dark current	1.27 e ⁻ /p/sec	3 e ⁻ /p/sec	1.03 e ⁻ /p/sec	0.477 e ⁻ /p/sec
Conversion Gain	0.23 e ⁻ /count	0.85 e ⁻ /count	0.25 e ⁻ /count	0.015 e ⁻ /count
Full well capacity	15000 e ⁻	200 e ⁻	1000 e ⁻	1000 e ⁻

Specification	Camera Interface
Digital Interface	PCI-Express Gen 3 USB 3.2 10 Gbps
Lens Interface	C-Mount
Mounting Points	2x 1/4" -20 TPI mounting points per side
Camera Weight	1.8 Kg, 4 lbs

Triggering Mode	Function
Input Trigger Modes	Trigger First: Sequence triggered on first rising edge
	Level Trigger: Exposure time is controlled by length of high trigger signal
	Edge Trigger: Each frame in sequence triggered by rising edge
	SMART Streaming: Fast iteration through multiple exposure times works with the 4 trigger outs to control multiple sources at multiple exposure time
Output Trigger Modes	Any Row: Expose signal is high while any row is acquiring data
	First Row: Expose signal is high while first row is acquiring data.
	Line Output: Expose signal provides rising edge for each row advanced by the rolling shutter readout
Effective Global Shutter Trigger Modes	All Rows: Expose out signal is high for Exposure time this keeps exposure time but drops frame rate
	Rolling Shutter: Expose out signal is high for Exposure time - readout time this keeps frame rate but drops exposure time
Output Trigger Signals	Expose Out (up to four signals), Read Out, Trigger Ready

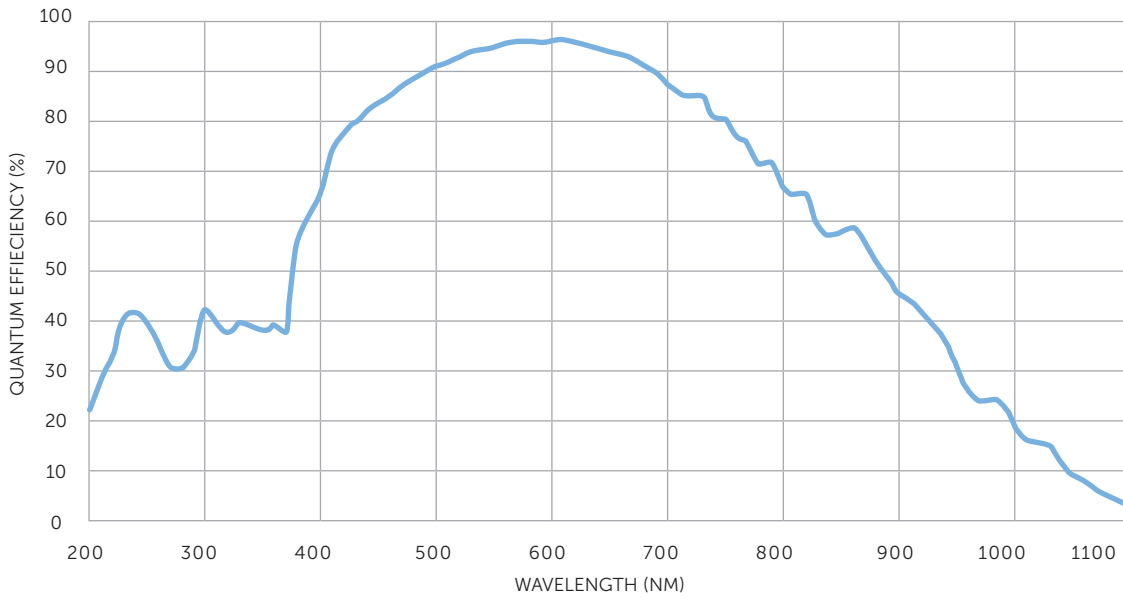

Accessories (Included)

- USB 3.2 Cable and Card
- Trigger Cable
- Power Supply
- Quickstart Guide
- PCIe Card and Cable

Accessories (Optional)

- Liquid Circulator
- Liquid Cooling Tubes

Frame Rate

Array Size	Dynamic Range		Speed		Sensitivity (CMS)		Sub-Electron	
	PCI-E	USB	PCI-E	USB	PCI-E	USB	PCI-E	USB
2400 x 2400	83	70	498	138	88	88	5.2	5.2

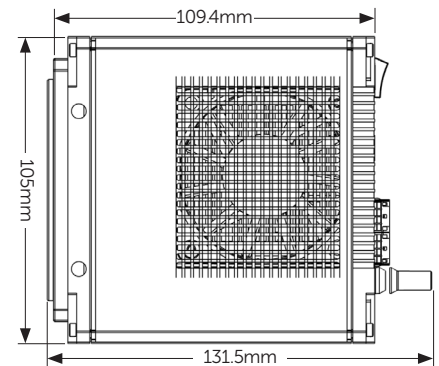
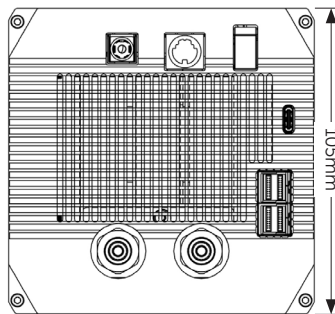
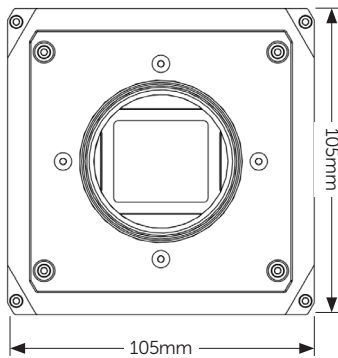

Teledyne Photometrics is a registered trademark. Kinetix is a trademark of Teledyne Photometrics. All other brand and product names are the trademarks of their respective owners.

Specifications in this datasheet are subject to change. Refer to the Teledyne Photometrics website for most current specifications.



www.photometrics.com
photometrics.info@teledyne.com/ tel: +1 520.889.9933



TELEDYNE IMAGING
 Everywhere you look™