



Large Field of View Scientific CMOS

Iris 15 Scientific CMOS camera is designed with a large field of view for live cell microscopy applications. Iris 15 delivers a 15 Megapixel sensor with a 25 millimeter field of view ensuring it can maximize the number of cells captured in a single frame. Iris 15 is equipped with an imaging area that is 50% larger than current sCMOS devices.

The 4.25µm pixels provide highly detailed images across the imaging plane and allow for Nyquist spatial sampling at 40X magnification. The camera can capture dynamic cellular events at 30 frames per second for the full frame, and at thousands of frames per second with regions.

The Iris 15 has a high quantum efficiency and low noise levels to maximize dim signal detection and allowing for the use of shorter exposure times to minimize cellular photo-damage.

The Iris 15 is the ideal camera to leverage the larger fields of view of newer microscopes and to image with high frame rates with high resolution for live-cell microscopy applications.



Primary applications:

- [Light Sheet Microscopy](#)
- [Multi-Color Fluorescence](#)
- [High Content Screening](#)
- [Tiling Applications](#)

- ▶ 15 Megapixel (5056 x 2960)
- ▶ 25mm Field of View
- ▶ 4.25µm x 4.25µm Pixel Area
- ▶ 30 Frames per Second
- ▶ 73% Quantum Efficiency

Features

Advantages

15 Megapixel Sensor
25mm Field of View

Maximize the imaging area and increase the number of cells acquired per frame

Optimized 4.25µm Pixel Size

Image the finer details of your samples and maintain proper spatial sampling at 40X magnification

Fast Frame Rates

Capture dynamic cellular events with high temporal resolution

High Quantum Efficiency

Maximizes the ability to detect signals, enables shorter exposure times and minimizes photo-toxicity

Low Read Noise

Maximize ability to detect extremely faint fluorescence signals

Large Dynamic Range

Measure both bright and dim signal levels within the same image

Programmable Scan Mode

Easily synchronize and control acquisitions with the rolling shutter readout

Specifications	Camera Performance
Sensor	Gpixel GSense 5130 Scientific CMOS sensor
Active Array Size	5056 x 2960 (15 Megapixel)
Pixel Area	4.25µm x 4.25µm (18.06µm ²)
Sensor Area	21.49mm x 12.61mm 24.9mm diagonal
Peak QE%	>73%
Read Noise	1.5e-
Full-Well Capacity	13,000e-
Bit Depth	16-bit
Readout Mode	Rolling Shutter Effective Global Shutter Programmable San Mode (PCI-E only)
Binning	2x2 (on FPGA)

Cooling Performance	Sensor Temperature	Dark Current
Air Cooled	0°C @ 30°C Ambient	0.5e-/pixel/second

Specification	Camera Interface
Digital Interface	PCIe, USB 3.0
Lens Interface	F-Mount
Mounting Points	¼"-20 mounting point on each side

Triggering Mode	Function
Input Trigger Modes	Trigger-First: Sequence triggered on first rising edge Edge: Each frame triggered on rising edge
Output Trigger Modes	Any Row: Expose signal is high while any row is acquiring data All Rows: Effective Global Shutter – Expose signal is high when all rows are acquiring data Signal is high for set Exposure time Rolling Shutter: Effective Global Shutter – Expose signal is high when all rows are acquiring data Signal is High for set Exposure time – Readout Time Line Output: Expose signal provides rising edge for each row advanced by the rolling shutter readout
Output Trigger Signals	Expose Out, Read Out, Trigger Ready

Programmable Scan Mode	Function
Scan Modes	Auto: Normal camera operation Line Delay: Control rolling shutter propagation rate by adding delays to the line time Scan Width: Control number of rows between reset and readout signal in the rolling shutter
Scan Direction	Down: Rolling shutter readout begins at the top of the sensor Up: Rolling shutter readout begins at the bottom of the sensor Down/Up Alternate: Rolling shutter readout alternates direction after starting at the top of the sensor

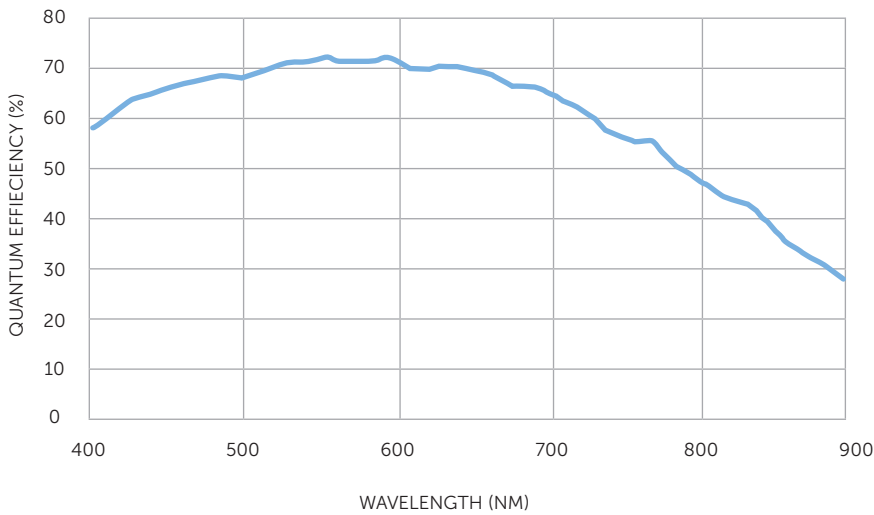

Frame Rate		
	PCI-Express	USB 3.0
Array Size	16-bit	16-bit
5056 X 2960	30	10
5056 X 1500	59	31
5056 X 512	174	91
5056 X 128	695	321

Accessories (Included)	
PCIe Card/Cable	Manual
Trigger Cable	QuickStart Guide
Power Supply	

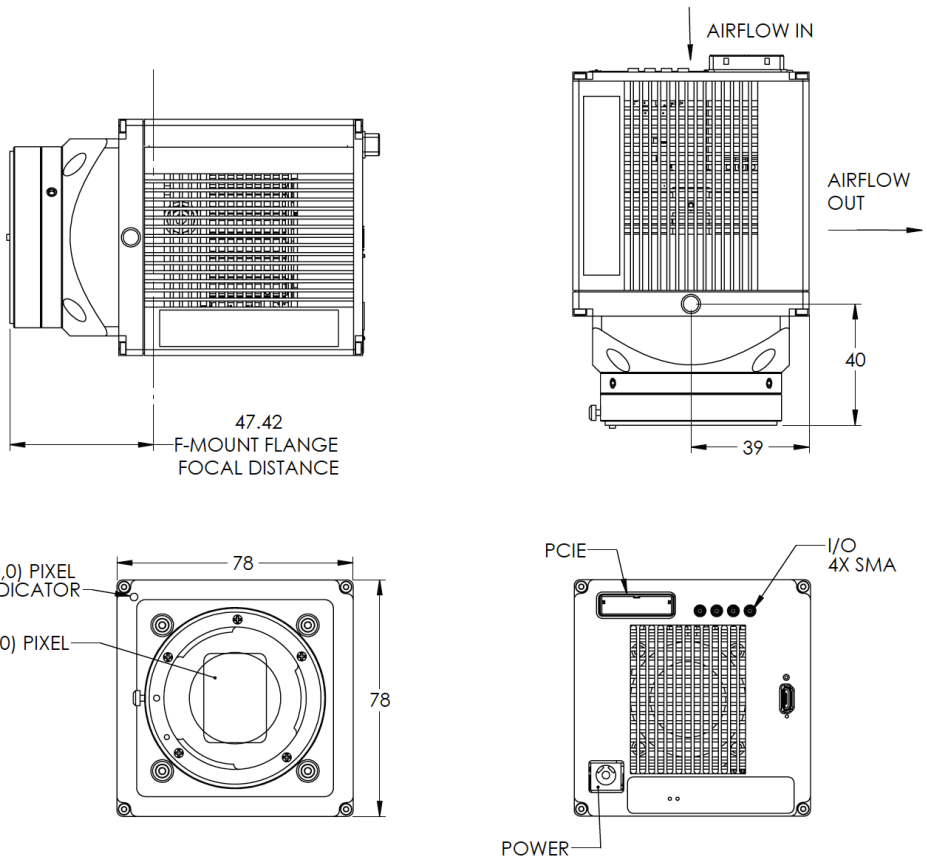

Teledyne Photometrics is a registered trademark.
 Iris 15 is a trademark of Teledyne Photometrics.
 All other brand and product names are the trademarks of their respective owners.

Specifications in this datasheet are subject to change.
 Refer to the Teledyne Photometrics website for most current specifications.