



Incubating Rocking & Waving Shakers



Save Incubator Space with Unique Benchtop Incubating Rocking and Waving Shakers

OHAUS Incubating Rocking and Waving Shakers are innovatively designed to incubate samples providing accurate and repeatable results. Rocking shakers provide a controlled see-saw like motion, while waving shakers offer a smooth, low-foaming three-dimensional wave motion. All models feature independent displays with intuitive touchpad controls. Both models include safety features that protect both the user and samples.

Standard Features:

- Electronic control allows simple tilt angle, speed and temperature adjustments while the unit is still running to achieve optimal mixing.
- Achieve reproducible results you can trust. Precisely adjust the tilt angle in 1° increments, vary the speed by 1 rpm and set temperature in 1°C increments with intuitive touchpad controls.
- Innovative speed ramping feature slowly increases speed to desired setpoint to avoid splashing. Smooth rocking or waving motion is maintained with unique, state-of-the-art motor and electronics.

Incubating Rocking & Waving Shakers

Model	ISRK04HDG	ISWV02HDG
Shaker Type	Rocking Shaker	Waving Shaker
Control	Digital	
Motion / Tilt Angle	Rocking, 0 – 15°	Waving, 0 – 20°
Speed Range	1 – 50 rpm	1 – 30 rpm
Speed Accuracy	± 1 rpm	
Temperature Range	Ambient +5 °C – 65 °C	
Temperature Uniformity	± 0.5 °C at 37 °C	
Timer	1 second – 160 hours	
Capacity	4.5 kg	2.3 kg
Working Environment	41 °F – 104 °F, 80% RH*, non-condensing / 5 °C – 40 °C, 80% RH, non-condensing	
Drive System	Stepper Motor	
Included Tray (L x W)	10 x 7.5 in. / 254 x 191 mm	9.25 x 7.25 in. / 235 x 184 mm
Tray Construction	Aluminum	
Overall Dimensions (L x W x H)	16.5 x 10.1 x 10.8 in. / 419 x 257 x 274 mm	
Inner Dimensions (L x W x H)	10.75 x 7.75 x 3.8 in. / 273 x 197 x 970 mm	10.75 x 7.75 x 3.4 in. / 273 x 197 x 860 mm
Net Weight	12.6 lb / 5.7 kg	13.7 lb / 6.2 kg
Power	120V, 3.74A, 50/60Hz	
Power Consumption	420 W	

*Relative Humidity

Other Standard Features and Equipment

Spill-resistant design, caution hot indicator, detachable 3-wire cord and plug (included)

Compliance

- **Product Safety:** CAN/CSA C22.2 61010-1, CAN/CSA C22.2 61010-2-010, CAN/CSA C22.2 61010-2-051, UL 61010-1
- **Electromagnetic Compatibility:** ICES-003 Class A, FCC Part 15 Class A
- **Compliance Marks:** TÜV SÜD

Applications

Hybridizations, cell cultures, blotting techniques, staining and destaining gels

Accessories

Incubating Rocking and Waving Shaker Accessories			
Item No.	Description	ISRK04HDG	ISWV02HDG
30400141	Dimpled Mat, Incubating Rocker ISRK04HDG	•	

Dimensions

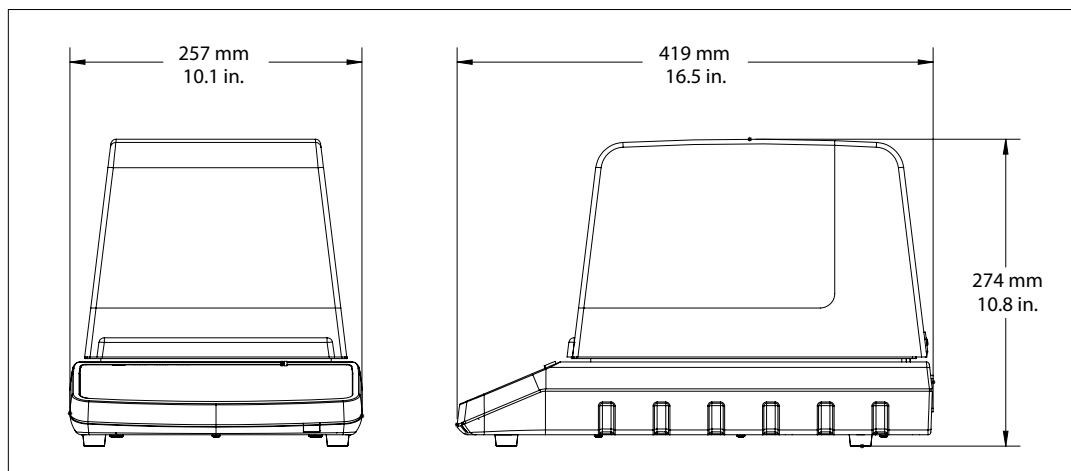

OHAUS CORPORATION

7 Campus Drive
Suite 310
Parsippany, NJ 07054 USA

Tel: 800.672.7722
973.377.9000
Fax: 973.944.7177

www.ohaus.com

The management system governing the manufacture of this product is ISO 9001:2015 certified.

