

## CUTSHEET

Front View

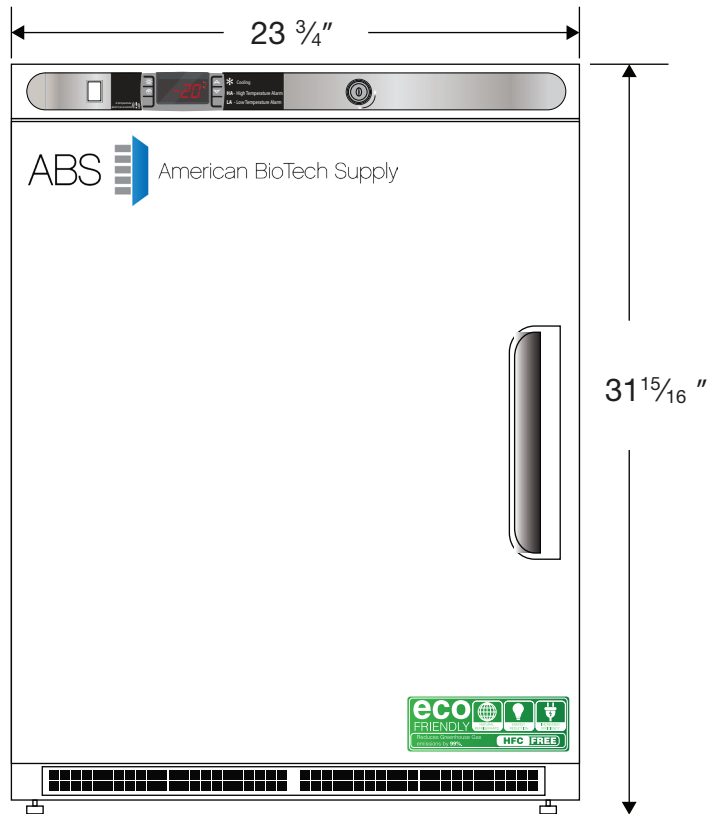

Side View

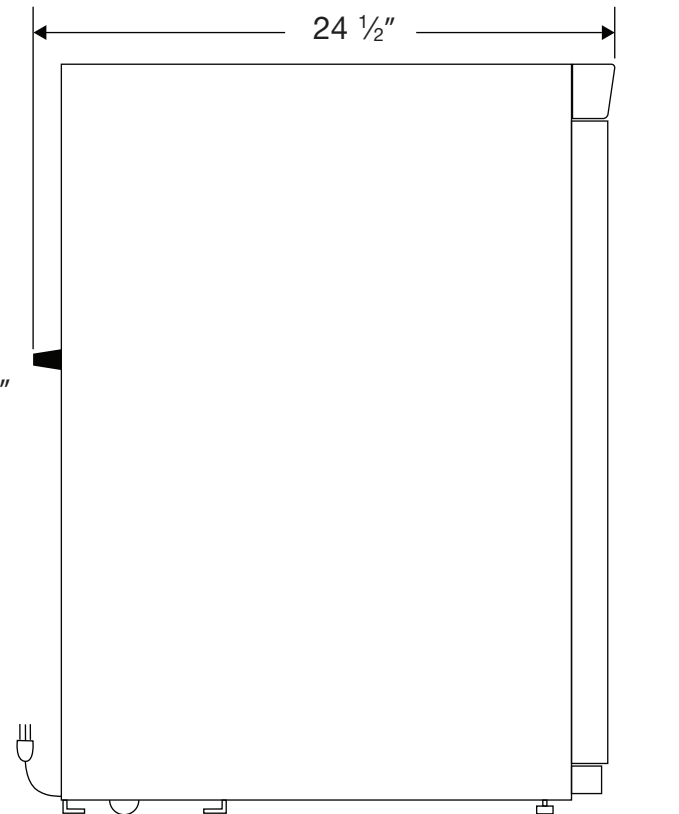

Top View

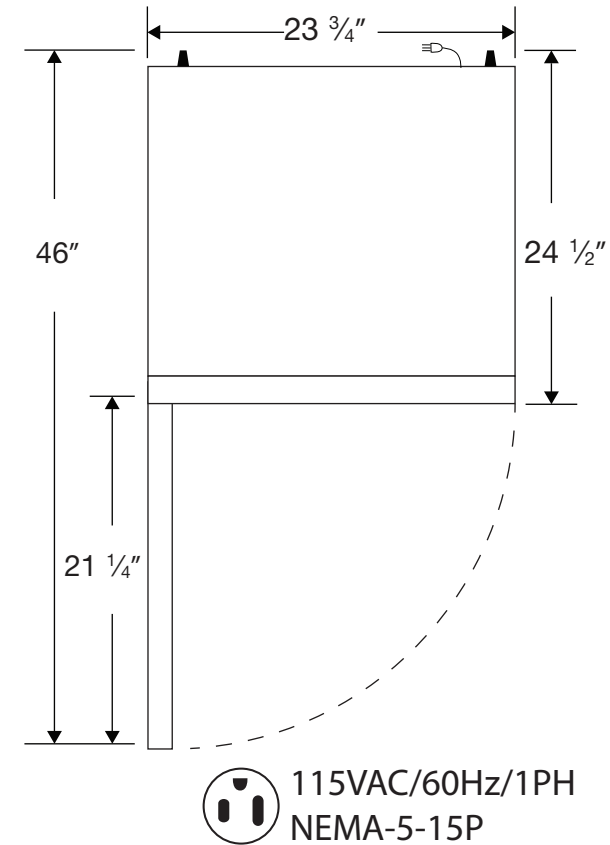

Cu. Ft	Defrost	Door	Int Door	Shelves	W"	D"	H"	Refrigerant	H.P.	Amps	Weight
4.2	Manual	1 Solid LH (Reversible)	0	2 Fixed	$23 \frac{3}{4}$	$24 \frac{1}{2}$	$31 \frac{15}{16}$	R600a	$\frac{1}{8}$	1.5	108 lbs.