

CUTSHEET

Front View

Side View

Top View

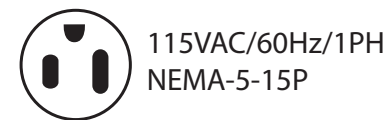
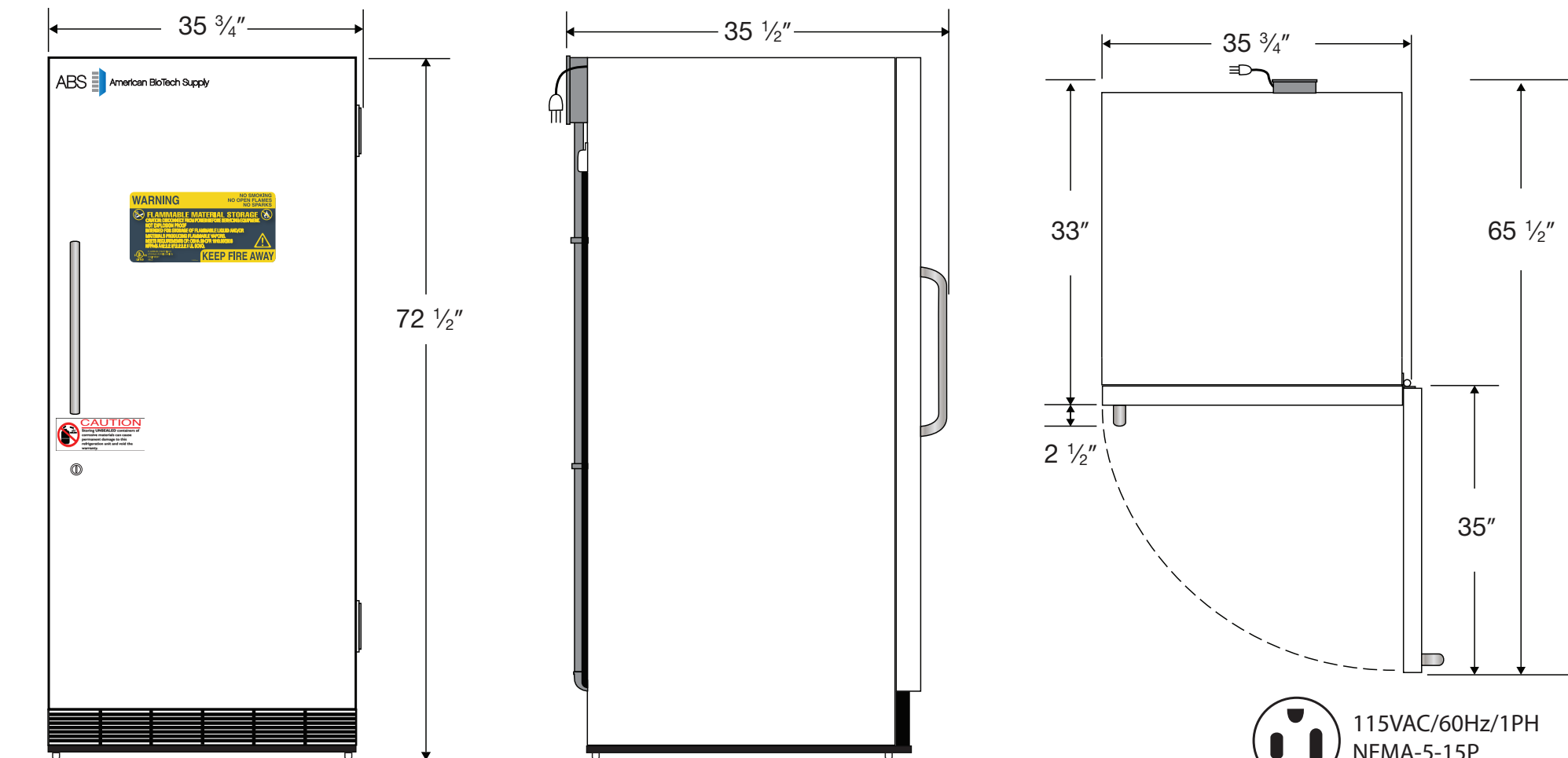

Cu. Ft	Defrost	Door	Int Door	Shelves	W"	D"	H"	Refrigerant	H.P.	Amps	Weight
30	Cycle	1 Solid	0	5 Adj.	35 3/4	35 1/2	72 1/2	R404a	1/3	6	321 lbs.