

CUTSHEET

Front View

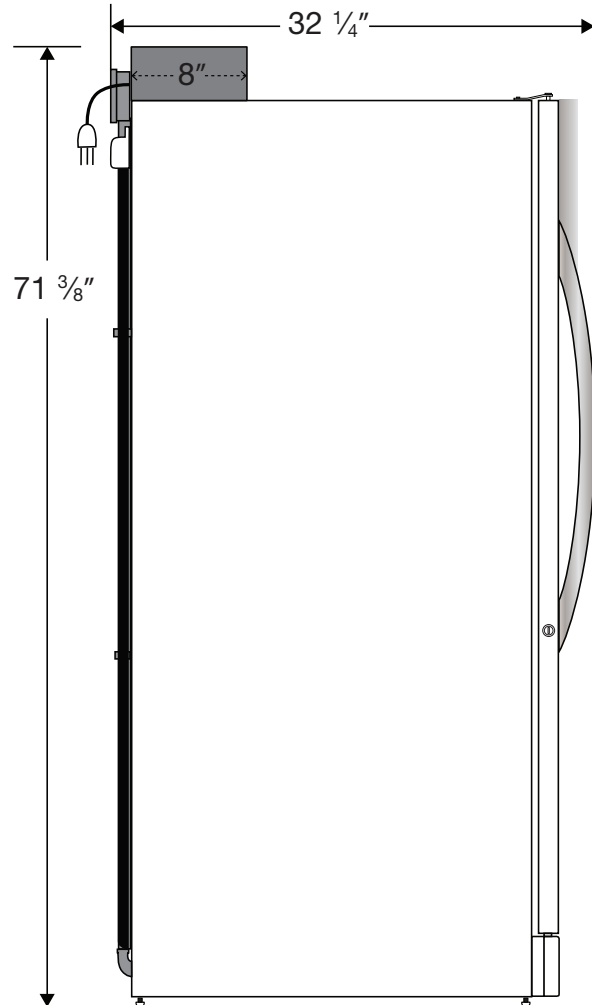

Side View



Top View

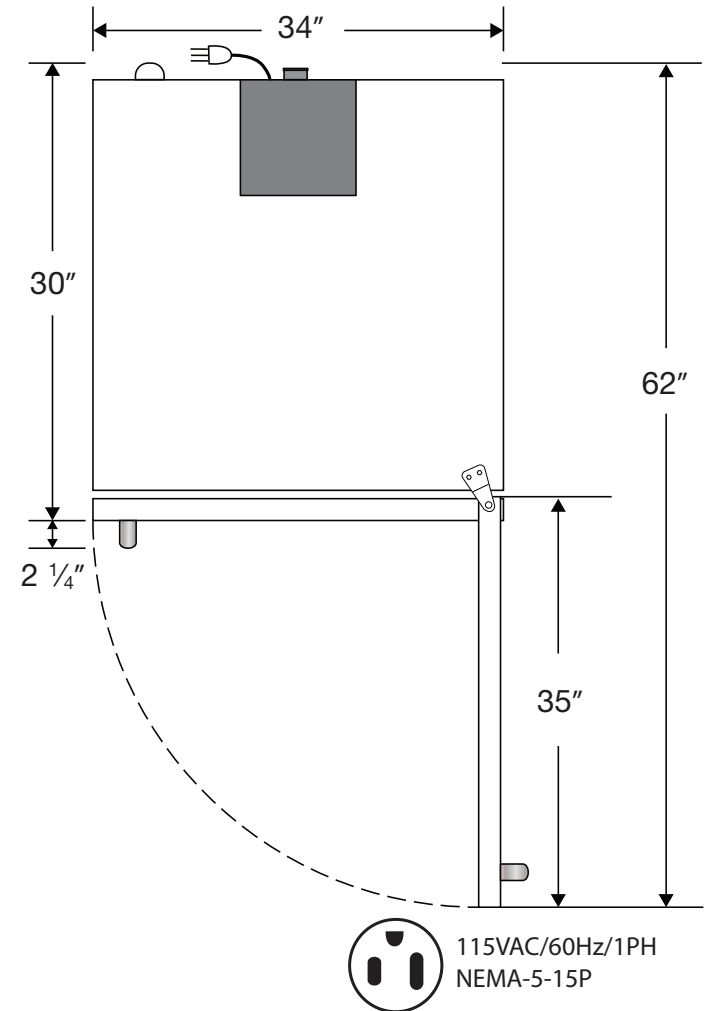

Cu. Ft	Defrost	Door	Int Door	Shelves	W"	D"	H"	Refrigerant	H.P.	Amps	Weight
17	Manual	1 Solid	0	3 Fixed	34	32 1/4	71 3/8	R134a	1/3	5	206 lbs.