



FEATURES

- Designed to control and power up to 8 monitors
- Connects any 2 or 3 wire gas monitors
- Digital and graphic LCD gas concentration display
- RS-485/Modbus RTU output
- Built-in power supply
- NEMA 4X IP66 Water-Resistant Enclosure

8 Channel Programmable Controller

ITEM #:99058

Product Summary

The PureAire 8 channel controller is designed to provide simple analog control or full featured digital control of toxic, LEL and oxygen deficiency monitors. The controller remotely powers and operates up to 8 monitors up to 100 feet from the controller. Capable of accepting any two or three wire gas detector, it features two user-adjustable common alarm relays which will, in the event of a gas leak, or a fault from one of the monitors, alert personnel. The multichannel controller incorporates various modes of operation for taking channels off line individually for performing calibration or sensor maintenance. Each channel can be individually designated with PPM, PPB or %. The LCD screen displays the readings from all 8 channels simultaneously, and the trends from each channel may be viewed in graph form over a period of time.

Facilities That Need This Product

- Cleanrooms
- Semiconductor
- Wastewater Treatment
- IVF
- Cryogenic Laboratories
- Food Flash Freezing

Why choose PureAire?

PureAire Monitoring Systems, Inc. is a leader in oxygen monitoring and gas detection. For over 20 years, we have dedicated ourselves to the safety of our clients, and the customers they serve, by manufacturing monitors that are long-lasting, accurate, and reliable. PureAire takes pride in providing exceptional customer service, along with 24/7 availability to our technical service department.

What is an 8 Channel Controller?

The 8 Channel Controller is designed to remotely operate and power up to 8 oxygen monitors or gas detectors in spaces where toxic gas levels pose a hazard to personnel.

What gases can be detected with an 8 Channel Controller?

PureAire's 8 channel controller connects up to 8 monitors which measure inert and toxic gases including, but not limited to, oxygen, nitrogen, argon, helium, carbon dioxide, ammonia, chlorine, methane, and ethylene.

Easy to Use

The controller comes pre-wired for easy installation. Simply connect the gas monitors to the controller (monitors may be located up to 100 feet from the controller), and connect the built-in power supply to the main power source. Gas levels are displayed clearly on the controller's screen for easy access and visibility.

Top Advantages of 8 Channel Controller



8 Channel Controller

PureAire's 8 Channel Controller allows simultaneous display and alarm functions for up to 8 gas monitors. The LCD screen displays each monitors' data as either a trend, graph, and ppm, ppb or percentage of gas concentration.



Easy To Use

The PureAire 8 Channel Controller is user friendly and easy to configure. Two user adjustable alarm levels per channel.

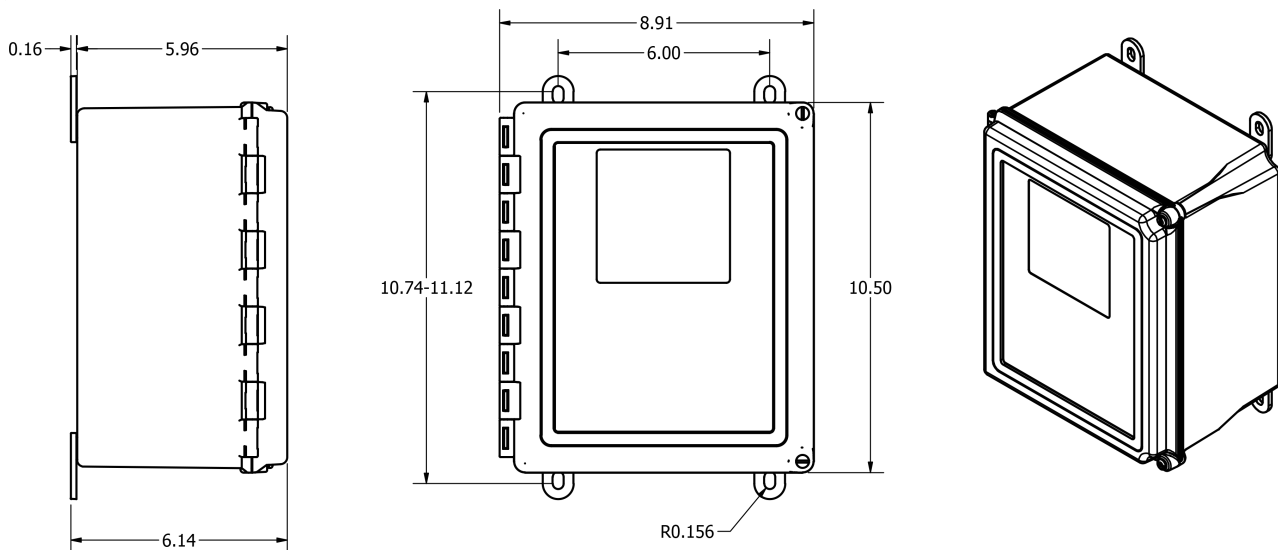

Top Accessories



**Air Check Explosion
Proof Combustible Gas
Monitor**

ITEM #: 95105



Universal Gas Detector

ITEM #: 99030



**Oxygen Deficiency
Monitor**

ITEM #: 99016



**Red Horn/
Strobe 24VDC**

ITEM #: 42002



1-888-788-8050

info@pureaire.net
pureairemonitoring.com

1140 Ensell Road
Lake Zurich, IL 60047
1-847-726-6000