



## Explosion Proof Oxygen Deficiency Monitor with 10+ Year Sensor

ITEM #: TX-1100EXR (99020, 99045)

### Product Summary

The Air Check Explosion Proof Oxygen Deficiency Monitor is perfect for facilities that use inert gases including, but not limited to, nitrogen, helium, and argon. The enclosure is specifically designed to prevent ignition of an explosion. The monitor is well suited for environments such as corn and grain processing facilities, powder coating plants, and the oil and gas industry where combustible dust, and ignitable fibers are present. The monitor will remain accurate at temperatures as low as -40C. PureAire's durable, non-depleting, zirconium oxide sensor will last up to 10+ years in a normal environment without needing to be replaced.

### Facilities That Need This Product

- *Aerospace*
- *Additive Manufacturing/3-D Printing*
- *Biomedical*
- *Food Processing*
- *Corn and Grain Processing*
- *Oil and Gas*

### FEATURES

- Suitable for Class 1 Div 2 Group B,C,D and Class 2, Div 2 E,F,G
- Long-life 10+ year average sensor life
- Two-Alarm setpoints for 19.5% and 18.0%
- UL, C UL and CE approval on Enclosure
- 3 year warranty
- Digital display, and 4-20mA analog output
- Wall mounting brackets
- Built-in flow sample pump

### Why choose PureAire?

PureAire Monitoring Systems, Inc. is an industry leader in oxygen monitoring and gas detection. For over 20 years, we have dedicated ourselves to the safety of our clients, and the customers they serve, by manufacturing monitors that are long-lasting, accurate, and reliable. PureAire takes pride in providing exceptional customer service, along with 24/7 availability to our technical service department.

### Why and Explosion Proof O2 Monitor?

The Air Check O2 Deficiency Monitor is designed for continuous monitoring where low oxygen levels and the risk of an explosion pose a hazard to personnel.

### What gases can can be detected with an Explosion Proof O2 Monitor?

PureAire's Explosion Proof O2 monitors can be used in an ambient atmosphere where inert gases, including nitrogen, argon, helium, and carbon dioxide are used.

### Easy to Use

Secure the monitor to the wall 3-5 feet from the gas and connect to 24VDC 700mA power source. The monitor will begin sampling oxygen levels after a brief startup period. Oxygen levels are displayed clearly on the screen for easy access and visibility.

# Top Advantages of Oxygen Deficiency Monitor



## Oxygen Deficiency Alarm

PureAire's O2 Monitor comes with 2 adjustable alarm setpoints that can connect to a horn/strobe, exhaust fan, 8 channel controller, remote display, or into building systems. Alarm signals also can tie into automatic shut-off valves when oxygen levels fall below the OSHA threshold.

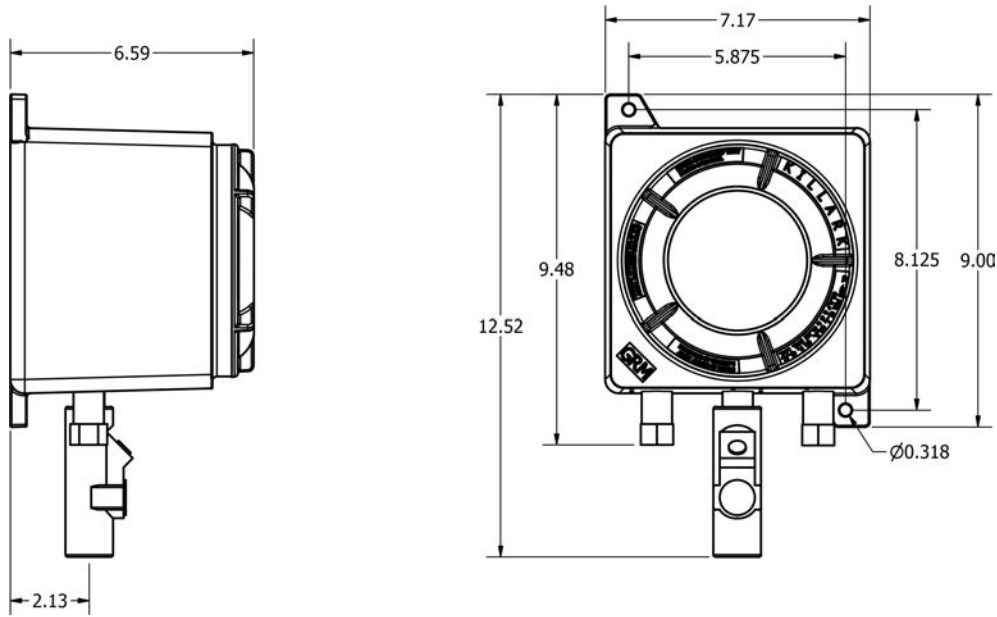

## Top Accessories



**8 Channel Programmable  
Controller for O2 or Gas  
Monitors**

ITEM #: 99058



**Remote Digital  
Display**

ITEM #: 99091



**Red Horn/Strobe  
24VDC**

ITEM #: 42002

**PureAire**  
monitoring systems, inc.

**1-888-788-8050**

info@pureaire.net  
pureairemonitoring.com

1140 Ensell Road  
Lake Zurich, IL 60047  
1-847-726-6000