



Forced Convection Constant Temperature Oven

DKN303/403/603/613 Instruction Manual

First Edition

Thank you for choosing a product of Yamato Scientific Co., Ltd.

- For proper equipment operation, please read and become thoroughly familiar with this instruction manual before use. Always keep equipment documentation safe and close at hand for convenient future reference.



Warning: Read instruction manual warnings and cautions carefully and completely before proceeding.

**Yamato Scientific America Inc.
Santa Clara, CA**

Table of Contents

| | |
|---|----|
| 1. SAFETY PRECAUTIONS | 3 |
| Explanation of Symbols..... | 3 |
| Symbol Glossary | 4 |
| Residual Risk Map | 5 |
| List of Residual Risks | 6 |
| Warnings and Cautions..... | 8 |
| 2. COMPONENT NAMES AND FUNCTIONS | 11 |
| DKN303/403/603/613..... | 11 |
| Components..... | 12 |
| Controller | 13 |
| 3. PRE-OPERATION PROCEDURES | 15 |
| Installation Precautions | 15 |
| 4. PRE-OPERATIVE PREPARATIONS | 18 |
| Installation method | 18 |
| Operation Modes and Functions | 21 |
| Operation and setting before operation | 23 |
| 5. OPERATION PROCEDURES..... | 25 |
| Independent Overheat Prevention Device Setup..... | 25 |
| Fixed temperature operation | 27 |
| Quick Auto Stop Operation..... | 30 |
| Auto stop operation | 33 |
| Auto start operation..... | 37 |
| Program operation auto start..... | 40 |
| Program operation | 43 |
| Wait Function | 51 |
| Repeat Function..... | 55 |
| Program Planning Worksheet..... | 57 |
| Calibration offset | 59 |
| Keypad lock | 61 |
| Auto-resume mode select | 62 |
| Option (output terminal)..... | 64 |
|  CAUTION | 64 |
| Option (External output terminal)..... | 66 |
| 6. MAINTENANCE PROCEDURES | 68 |
| MAINTENANCE PROCEDURES | 68 |
| 7. EXTENDED STORAGE AND DISPOSAL | 70 |
| Extended Storage / Unit Disposal..... | 70 |

| | |
|--|----|
| Dispose of or recycle this unit in a responsible and environmentally friendly manner. | 70 |
| 8. TROUBLESHOOTING | 71 |
| Troubleshooting Guide..... | 71 |
| Reading Error Codes | 72 |
| 9. SERVICE & REPAIR..... | 73 |
| Requests for Repair | 73 |
| 10. SPECIFICATIONS | 74 |
| 11. OPTIONAL ACCESSORIES | 77 |
| 12. LIST OF HAZARDOUS SUBSTANCES | 78 |
| 13. STANDARD INSTALLATION MANUAL | 79 |

1. SAFETY PRECAUTIONS

Explanation of Symbols

A Word Regarding Symbols

Various symbols are provided throughout this text and on equipment to ensure safe operation. Failure to comprehend the operational hazards and risks associated with these symbols may lead to adverse results as explained below. Become thoroughly familiar with all symbols and their meanings by carefully reading the following text regarding symbols before proceeding

 **Warning** Signifies a situation which may result in serious injury or death (Note 1.)

 **Caution** Signifies a situation which may result in minor injury (Note 2) and/or property damage (Note 3.)

(Note 1) Serious injury is defined as bodily wounds, electrocution, bone breaks/fractures or poisoning, which may cause debilitation requiring extended hospitalization and/or outpatient treatment.

(Note 2) Minor injury is defined as bodily wounds or electrocution, which will not require extended hospitalization or outpatient treatment.

(Note 3) Property damage is defined as damage to facilities, equipment, buildings or other property.

Symbol Meanings



Signifies warning or caution.
Specific explanation will follow symbol.



Signifies restriction.
Specific restrictions will follow symbol.



Signifies an action or actions which operator must undertake.
Specific instructions will follow symbol.

1. SAFETY PRECAUTIONS

Symbol Glossary

WARNING / CAUTION



General



Danger!: High Voltage



Danger!: High Temperature



Danger!: Moving Parts



Danger!: Blast Hazard



Caution: Shock Hazard!



Caution: Burn Hazard!

Restriction



General Restriction



No Open Flame



Do Not Disassemble



Do Not Touch

ACTION



General Action Required



Connect Ground Wire



Level Installation



Disconnect Power



Inspect Regularly

1. SAFETY PRECAUTIONS

Residual Risk Map

These figures indicate positions of caution labels.

The numbers shown in the figure indicate the numbers listed in the "List of Residual Risks" in this manual.

For details of individual residual risks, see the List of Residual Risks.

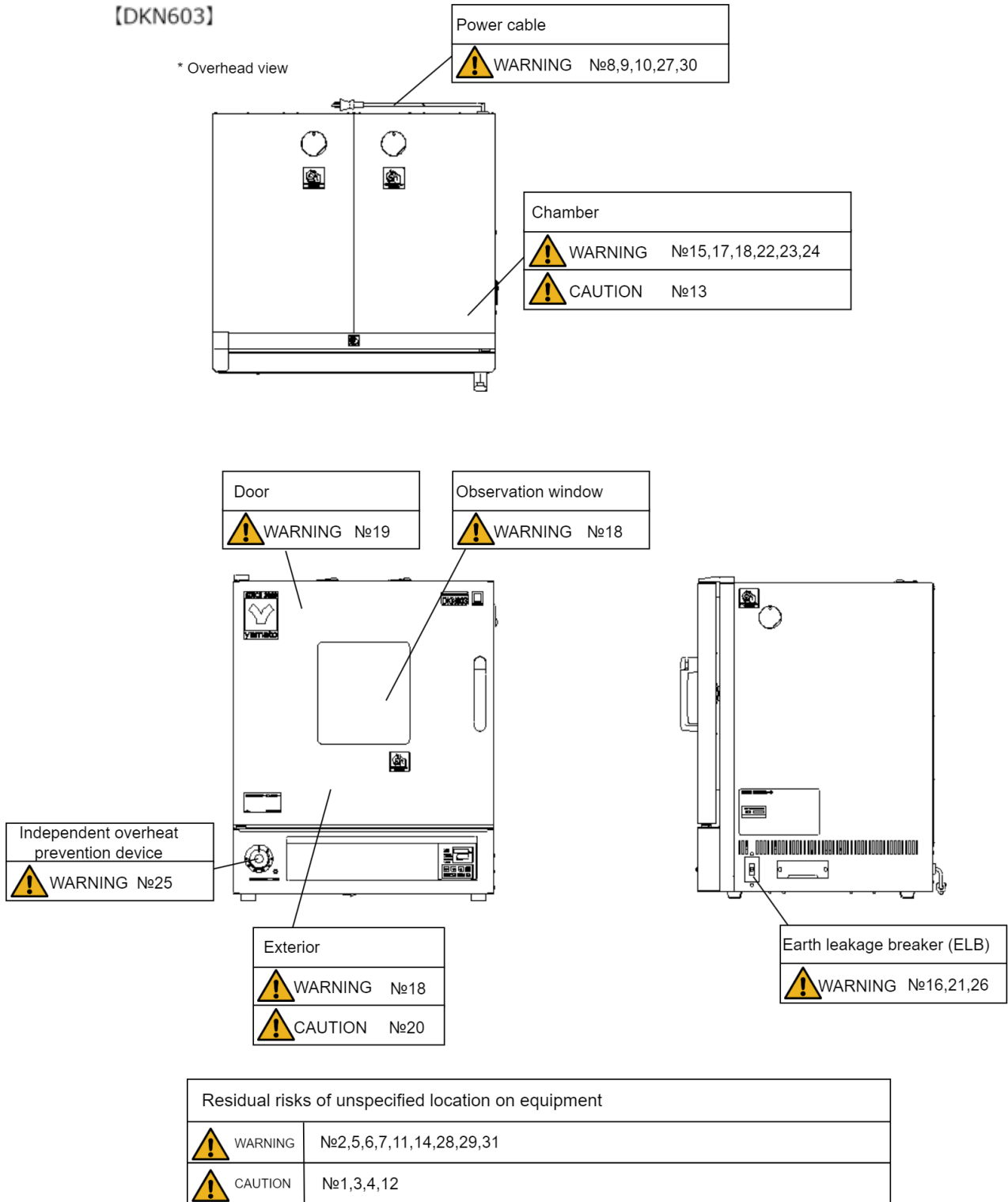

*Contact original dealer of purchase if the nameplates and caution labels have come off, or become illegible. New nameplates are available at cost. We will send you a new nameplate (for charge)

1. SAFETY PRECAUTIONS

List of Residual Risks

List of residual risks (instructions for risk avoidance)

This list summarizes residual risks to avoid personal injuries or damages to properties during or related to the use of equipment.

Be sure to fully understand or receive instructions on how to use, maintain and inspect equipment before starting operation.

| Loading/Installation | | | |
|----------------------|-----------------|---------------------|---|
| No. | Degree of risks | Risk description | Protective measures taken by the user |
| 1 | CAUTION | Injury | Always use cargo-handling equipment to move or install unit. Transport unit with sufficient number of people and an appropriate work method when carrying out manually.(P.15) |
| 2 | WARNING | Fire/Electric shock | Choose an appropriate installation site.(P.15) |
| 3 | CAUTION | Injury | Install unit on a level surface.(P.16) |
| 4 | CAUTION | Injury | Take appropriate safety measures when installing.(P.16) |
| 5 | WARNING | Fire | Install equipment in a well-ventilated place(P.16) |
| 6 | WARNING | Fire/Electric shock | Install in a dry location.(P.16) |
| 7 | WARNING | Explosion/fire | Ground wire MUST be connected properly(P.8) |
| 8 | WARNING | Fire/Electric shock | Always connect power cable to appropriate facility outlet or terminal.(P.16) |
| 9 | WARNING | Fire/Electric shock | Handle power cable with care.(P.9) |
| 10 | WARNING | Fire/Electric shock | Ground wire MUST be connected properly(P.8) |
| 11 | WARNING | Fire/Electric shock | DO NOT disassemble or modify equipment.(P.10) |
| 12 | WARNING | Injury | Use optional stacking hardware for double stacking (P. 17) |
| 13 | CAUTION | Fire | Install equipment in a well-ventilated place(P.16) |

| Use | | | |
|-----|-----------------|------------------------------|--|
| No. | Degree of risks | Risk description | Protective measures taken by the user |
| 14 | WARNING | Explosion/fire | DO NOT process explosive or flammable substances(P.9) |
| 15 | WARNING | Fire | When using resin containers for processing, use caution not to exceed their heat-resistant temperature.(P.9) |
| 16 | WARNING | Fire/Electric shock | Turn OFF ELB immediately when an abnormality occurs.(P.8) |
| 17 | WARNING | Fire / electric shock / burn | Take care not to drop test samples or objects into the inside unit.(P.9) |
| 18 | WARNING | Burn | DO NOT touch hot surfaces(P.9) |
| 19 | WARNING | Fire / Burn | Carefully handle test samples following high temperature operation.(P.9) |
| 20 | CAUTION | Injury | DO NOT climb or place any objects on top of equipment.(P.10) |

1. SAFETY PRECAUTIONS

| | | | |
|----|---------|---------------------|--|
| 21 | WARNING | Fire | DO NOT operate equipment during thunderstorms(P.10) |
| 22 | WARNING | Fire/Burn | Carefully handle test samples.(P.20) |
| 23 | WARNING | Leak Current / Burn | When processing wet samples, remove as much of the moisture as possible beforehand, and open the exhaust port.(P.20) |
| 24 | WARNING | Burn/Injury/Fire | DO NOT place samples exceeding 15 kg on a single rack. Space test samples appropriately and leave more than 30% of space on chamber rack. (P.19) |
| 25 | WARNING | Fire | Set the independent overheat prevention device activation temperature.(P.25) |

Daily inspection/maintenance

| No. | Degree of risks | Risk description | Protective measures taken by the user |
|-----|-----------------|---------------------|---|
| 26 | WARNING | Fire/Electric shock | Inspect earth leakage breaker on a regular basis.(P.68) |
| 27 | WARNING | Fire/Electric shock | Be sure to disconnect power cable before daily inspection and maintenance. (P.68) |
| 28 | WARNING | Burn | Perform inspections and maintenance when unit is at room temperature. (P.68) |
| 29 | WARNING | Fire/Electric shock | DO NOT touch hot surfaces(P.9) |

Extended storage/disposal

| No. | Degree of risks | Risk description | Protective measures taken by the user |
|-----|-----------------|---------------------|--|
| 30 | WARNING | Fire/Electric shock | Turn off the earth leakage breaker and remove the power plug.(P.70) |
| 31 | CAUTION | Injury | Do not leave unit in a location where children may have access(P.70) |

1. SAFETY PRECAUTIONS

Warnings and Cautions



WARNING



Install in a location free of flammables and explosives.



Never install or operate unit in a flammable or explosive gas atmosphere. Unit is NOT fire or blast resistant. Simply switching earth leakage breaker (ELB) "ON" or "OFF" can produce a spark, which can then be relayed during operation, causing fire or explosion when near flammable or explosive fluids, chemicals or gases/fumes.

See "[12. LIST OF HAZARDOUS SUBSTANCES\(P.78\)](#)" for explosive and flammable substances.



Ground wire MUST be connected properly [DKN303/403/603 specifications]



- Connect power cable to a grounded outlet in order to avoid electric shock.
- Never insert multiple plugs into a single outlet. Doing so may result in power cable overheating, fire or drop in voltage.

Contact original dealer of purchase for location-specific electrical requirements.

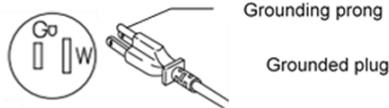

Ground wire must be connected (round terminal) [DKN613 specifications].



- Securely connect to a distribution board.
- No power plugs or connectors of any kind are included with DKN613 unit. When using a power plug, use a plug that meets the voltage and electrical capacity. (DKN613 is single-phase AC200V)

*Contact original dealer of purchase for location-specific electrical requirements.

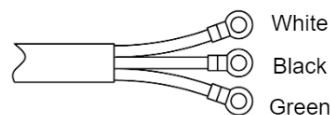

| Core color | Wiring on distribution board |
|------------|------------------------------|
| White | Neutral |
| Black | Live |
| Green | Ground |















Turn OFF ELB immediately when an abnormality occurs.



If unit begins emitting smoke, fire or abnormal odors for reasons unknown, turn OFF ELB immediately, disconnect power cable from power supply, and contact original dealer of purchase for assistance. Failure to do so may result in damage to components, fire or electric shock. Never attempt to disassemble or repair unit. Repairs should always be performed by a certified technician.

1. SAFETY PRECAUTIONS

Warnings and Cautions

| | |
|---|---|
|    | <p>Handle power cable with care.</p> <p>Observe the following precautions in order to prevent fire, electric shock, or other accidents.</p> <ul style="list-style-type: none">• Do not operate unit with power cable bundled or tangled.• Do not modify, bend, forcibly twist or pull on power cable.• Do not risk damage to power cable by positioning it under desks or chairs, or by allowing it to be pinched in between objects.• Do not place power cable near kerosene/electric heaters or other heat-generating devices.• Regularly check and clean the connection part, and avoid using an old outlet.• Turn off ELB immediately and disconnect from facility terminal or outlet, if power cable becomes partially severed or damaged in any way. Contact original dealer of purchase for information about replacing power cable. |
|   | <p>DO NOT process explosive or flammable substances</p> <p>Never attempt to process explosives, flammables or any items which contain explosives or flammables. Fire or explosion may result. See "12. LIST OF HAZARDOUS SUBSTANCES(P.78)" for information on flammable and explosive gases.</p> |
|  | <p>DO NOT touch hot surfaces</p> <p>Do not touch high temperature portions during or immediately after operation. Burn injury may result. Always wear protective equipment and be careful not to contact with hot surfaces when handling test samples</p> |
|  | <p>When using resin containers for processing, use caution not to exceed their heat-resistant temperature.</p> <p>When using resin containers for processing, confirm that they conform to the heating specifications of this unit. Heating resin beyond capacity to withstand temperature will cause resin to melt and may result in fire or equipment malfunction.</p> |
|  | <p>Take care not to drop test samples or objects into the inside unit.</p> <p>In the event that a foreign object accidentally falls inside, turn OFF ELB immediately, disconnect power cable and contact original dealer of purchase for assistance. Failure to do so may result in fire or electric shock.</p> |
|  | <p>Carefully handle test samples following high temperature operation.</p> <p>Interior surfaces and sample/process items are hot during operation and for some time after operation. Be careful with hot items in order to avoid burn injury. Do not turn the power to "OFF " at high temperatures. Always wear protective equipment when handling test samples during operation or right after operation.</p> |
|    | <p>Be careful when opening the door at high temperatures</p> <p>Maintain a safe distance until hot air, expelled from chamber, has dissipated when opening door during operation or Immediately after the end of operation. When working with the door open, turn the power to "ON " and check the interior temperature. Do not touch internal door or other heated interior surfaces. Severe burns may result. Make sure it is cold enough before opening the door. Be advised that if a fire/smoke alarm is installed in close proximity to unit, it may be set off when chamber door is opened and hot air or smoke is expelled.</p> |

1. SAFETY PRECAUTIONS

Warnings and Cautions

| | |
|---|---|
|  | Opening/Closing door |
| | When opening or closing the door keep hands and face away from area that the door swings. The door may hit against them, causing an injury. |

| | |
|---|---|
|  | Be aware of performance degradation when using cable holes |
| | Whenever a manual temperature gauging sensor or probe is inserted through the cable port, close the port cover as fully as possible and completely seal any gaps with heat-resistant insulation or sealant. If the seal is inadequate, temperature characteristics or other performance properties will be degraded and inaccurate. |

| | |
|---|--|
|  | DO NOT disassemble or modify equipment. |
| | Never attempt to disassemble or modify unit. Doing so may cause malfunction, fire, electric shock, or personal injury. Note that any malfunction resulting from unauthorized modifications or customizations to unit will void the warranty. |

| | |
|---|--|
|  | Inspect regularly |
| | Circuit breakers and overheating prevention devices are important security devices. Inspect regularly. Refer to " Inspect earth leakage breaker on a regular basis.(P.68) " for the inspection method. |



CAUTION

| | |
|---|--|
|  | DO NOT operate equipment during thunderstorms |
| | In the event of a thunderstorm, turn OFF ELB and disconnect power cable immediately. A direct lightning strike may cause equipment damage, fire or electric shock, resulting in serious injury or death. |

| | |
|---|---|
|  | DO NOT climb or place any objects on top of equipment. |
| | Personal injury or equipment malfunction may result. |

2. COMPONENT NAMES AND FUNCTIONS

DKN303/403/603/613

Instruction manual QR cord

Link to the instruction manual on our website.

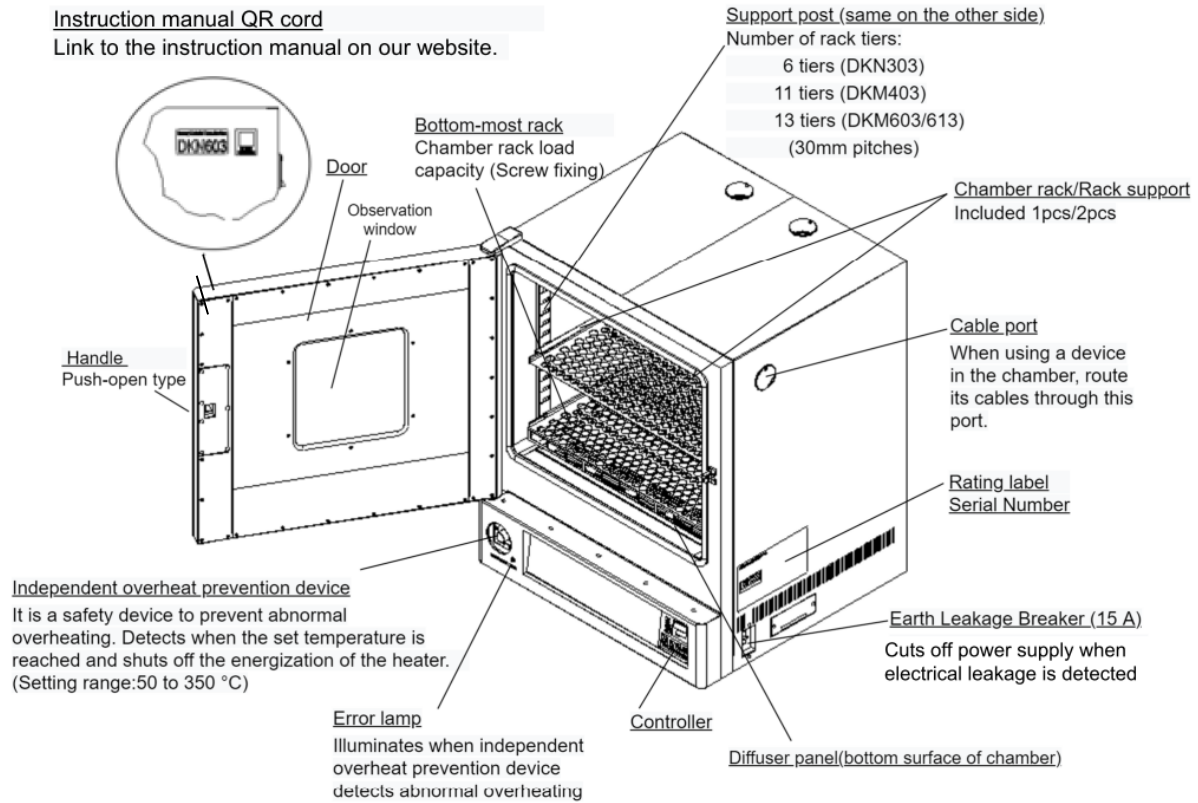

Rear view

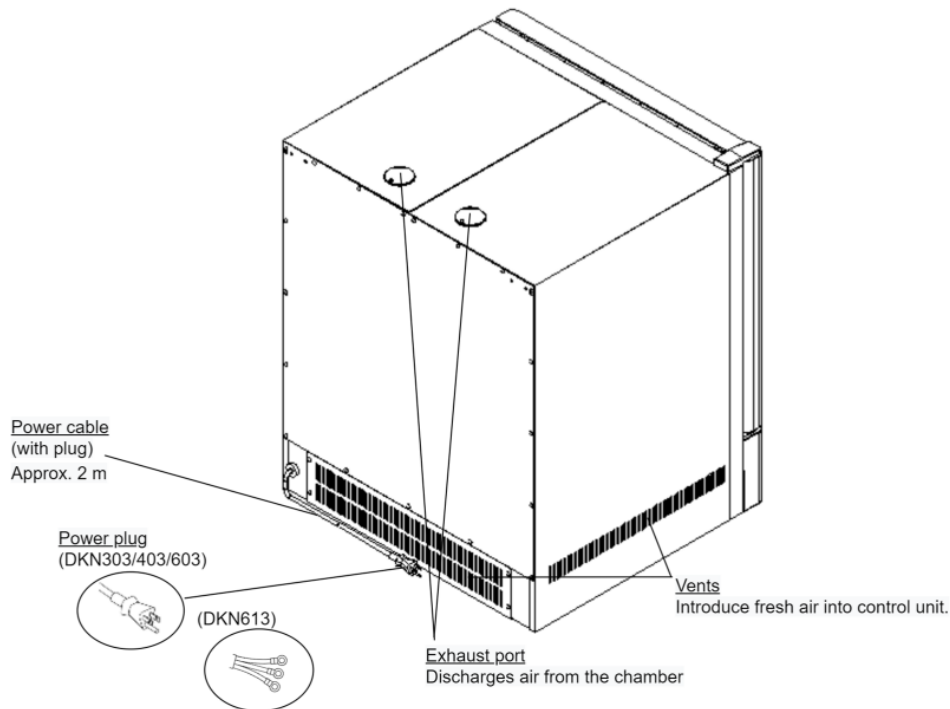

2. COMPONENT NAMES AND FUNCTIONS

Components

- Forced air circulation system

Air circulation inside the chamber provides good temperature distribution inside the chamber, making it ideal for general drying processes.

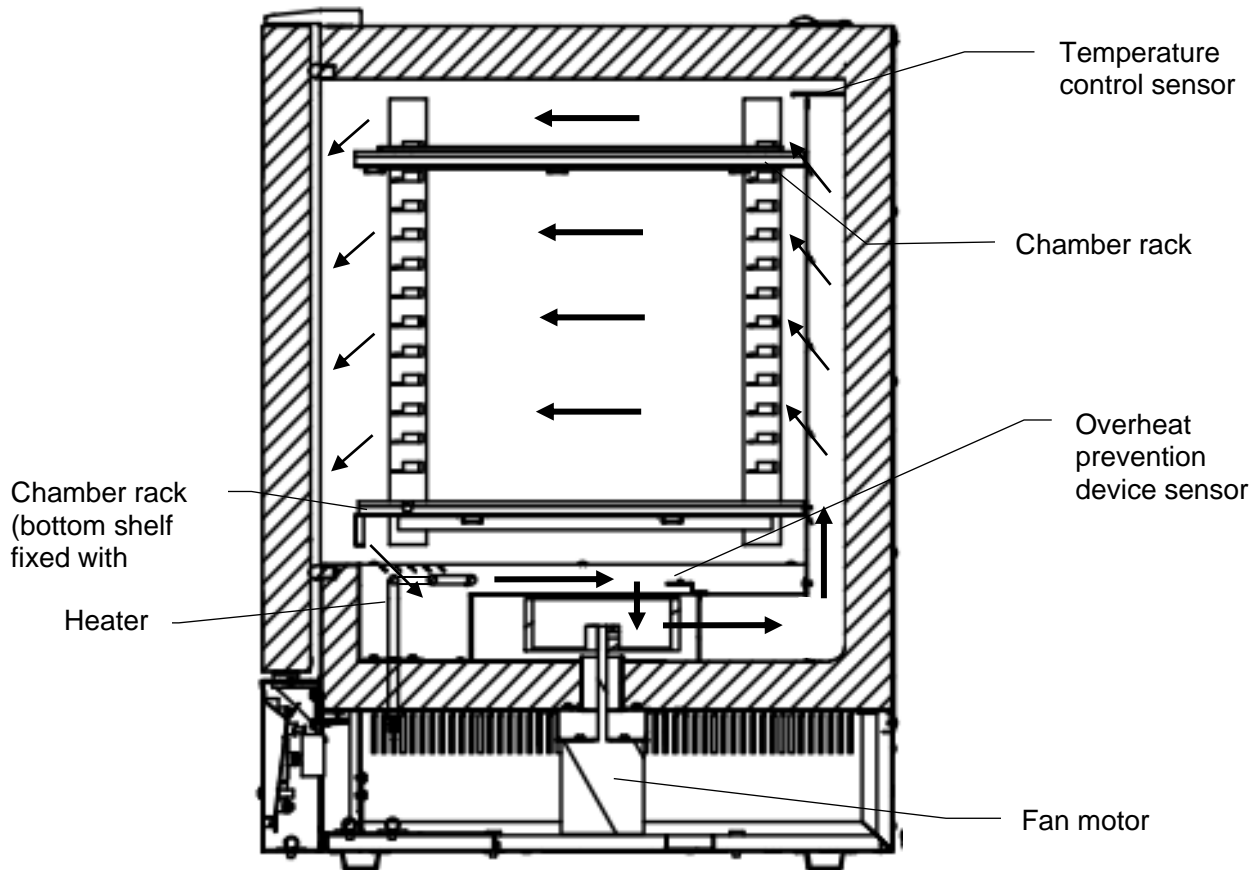

Cross-sectional diagram

2. COMPONENT NAMES AND FUNCTIONS

Controller





















| No | Parameter | 機能 |
|----|-----------------------------|---|
| ① | RUN/STOP key | Press to start or stop an operation. |
| ② | ▲▼ key | Used to increase or decrease the set value, or switch between functions and displays. Pressing the ▼ key during operation other than Fixed temperature operation switches indications described in ⑮ |
| ③ | ENTER key | Press to finalize setting |
| ④ | FIXED TEMP key | Press to select Fixed temperature operation |
| ⑤ | TIMER key | Press to select and set a timed operation Quick auto stop, Auto stop, Auto start, and Program operations may be selected * Quick auto stop is available only in Fixed temperature operation |
| ⑥ | PROGRAM key | Press to begin creating programs or to select Program operation Programs 1 to 6 (PrG1 to 6) can be set. |
| ⑦ | SUB MENU key | Press and hold for two seconds to enter Submenu Calibration offset, Keypad lock, Auto-resume function, Wait function, and Program repeat function may be set |
| ⑧ | HEATER Lamp | Illuminates when heater is on and drawing power |
| ⑨ | ALARM lamp | Illuminates when an error occurs |
| ⑩ | AUTO STOP Lamp | ⑫ illuminates in Fixed temperature operation, flashes while setting |
| ⑪ | AUTO START Lamp | ⑩⑫ illuminate in Auto stop and Quick auto stop operations, flash while setting . |
| ⑫ | FIXED TEMP. lamp. | ⑩⑫ illuminate in Auto start operation, flash while setting. |
| ⑬ | PROGRAM lamp | ⑬ illuminates in Program operation, flashes while setting ⑩⑬ illuminate in Program auto start operation, flash while setting Flashes during each setting and Illuminates during operation * ⑩ does not flash while setting Quick auto stop operation |
| ⑭ | Temperature reading display | Shows current chamber temperature, setting characters, and error codes |
| ⑮ | Temperature setting display | Shows temperature setting, timer set value, remaining time, operation mode, and program step number |

2. COMPONENT NAMES AND FUNCTIONS

Controller

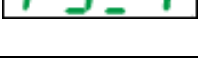
◆Display Characters

All characters displayed when making settings and during operation are defined as follows:

| Character | Letters | Panel Item | Description |
|---|-------------|---------------------------------|---|
|  | Fix | Fixed temperature operation | Appears during Fixed temperature operation |
|  | Sv | Temperature setting | Appears while entering temperature settings for Fixed temperature operation and timed operations |
|  | AStP | Auto stop | Appears during Auto stop operation |
|  | AStR | Auto start | Appears during Auto start operation |
|  | PStR | Program Auto Start | Appears during Program auto start operation |
|  | W_F | Auto Stop Weight Setting | Wait mode ON/OFF setting on Auto stop and Quick auto stop operations |
|  | tim | Timer setting | Appears while entering timer settings |
|  | PrG 1-6 | Program number | Means the program number of programs 1-6 Refer to " Program operation(P.43) " |
|  | End | End of operation | Appears when a programmed operation or a timed operation is completed |
|  | Sv_ 1-30 | program Temperature setting | Appears while setting temperature for each step in a program. Shows from Sv_1 to Sv_30 (for PrG1) |
|  | t_ 1-30 | program Timer setting | Appears while setting timer for each step in a program Shows from t_1 to t_30 (for PrG1) |
|  | W_ 1-30 | program Step Wait setting | Appears while setting Wait mode on each program step Shows from W_1 to W_30 (for PrG1) Refer to " Wait Function(P.53) ". |
|  | PS_ 1-30 | Point of return | Appears when selecting step numbers to be repeated in a program Shows from PS_1 to PS_30 (for PrG1) Refer to " Repeat Function(P.55) ". |
|  | Pc_ 1-30 | Number of times to repeat | Appears when setting the number of times to repeat steps in a program Shows from Pc_1 to Pc_30 (for PrG1) Refer to " Repeat Function(P.55) ". |
|  | St_ 1-30 | program Step number | Appears to show the currently running step Shows from St_1 to St_30 (for PrG1) |
|  | SKiP | Step Skip function | Appears when selecting which program step to skip |
|  | HoLd | Step Hold function | Appears while setting step hold function |
|  | cAL | Calibration Offset function | Appears while entering offset temperature values Refer to " Using calibration offset(P.59) ". |
|  | Lock | Set value lock 機能 | Appears while setting Keypad lock function Refer to " Keypad lock(P.61) ". |
|  | Pon | Auto-resume mode select | Appears while setting Auto-resume function Refer to " Auto-resume mode select(P.62) ". |

*Refer to "[Operation and setting before operation \(P.23\)](#)" for key operation flow.

3. PRE-OPERATION PROCEDURES

Installation Precautions



Choose an appropriate installation site.

DO NOT install unit:

- where installation surface is not completely level, not even or not clean.
- where flammable or corrosive gases/fumes may be present
- where external temperature will exceed 35 °C will fall below 5 °C
- where liquid is assumed to splash on unit
- where external temperature will fluctuate largely.
- in excessively humid or dusty locations.
- in direct sunlight or outdoors.
- where there is constant vibration.
- in direct contact with the outside air
- where power supply is erratic.
- where there is a risk of freezing or condensation.
- where exposed to a strong wind.
- in the proximity of, particularly right below a fire alarm.
- where there is combustible material nearby.
- in direct contact with the outside air



Install unit in a location with sufficient space, as specified below.

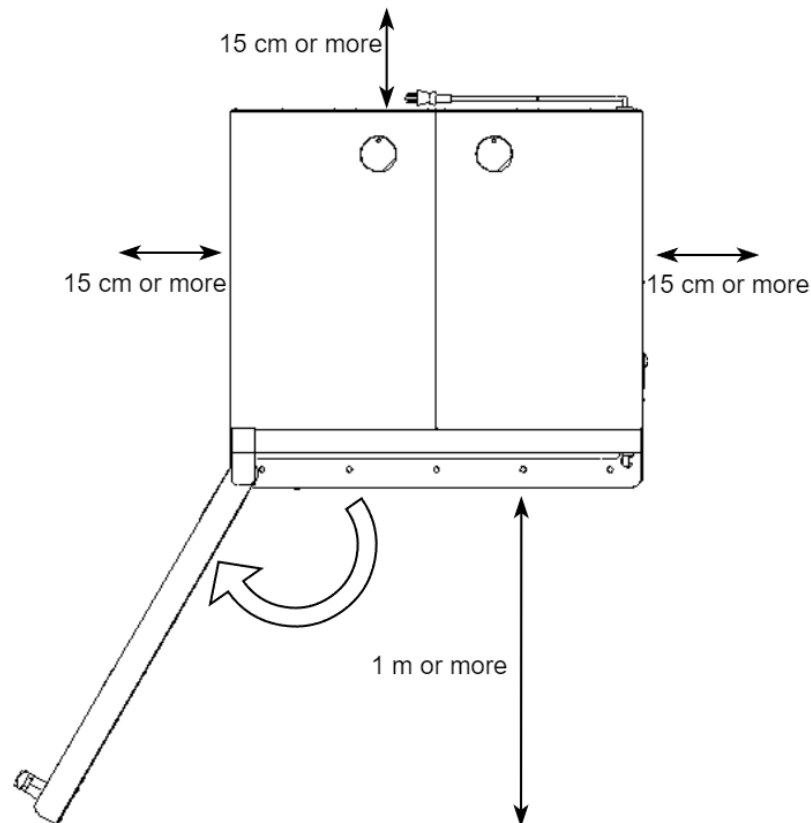







Leave 60 cm or more space above unit

The recommended space is described in reference to the Tokyo Fire Prevention Ordinance. Install unit as stipulated by the ordinance of each prefecture.

3. PRE-OPERATION PROCEDURES

Installation Precautions

| | |
|---|--|
|  | Always use cargo-handling equipment to move or install unit. |
| | Always use cargo-handling equipment to move or install unit. Transport unit with sufficient number of people and an appropriate work method when carrying out manually. *Approx. weight DKN303: approx. 35 kg DKN403: approx. 50 kg DKN603: approx. 70 kg DKN613: approx. 71 kg |
|  | Install unit on a level surface. |
| | Install unit on level and even surface. Failure to do so may cause abnormal vibrations or noise, resulting in possible complications and/or malfunction. |
|  | Take appropriate safety measures when installing. |
| | Implement appropriate safety measures for the installation environment. Unit may tip over or fall, causing injury or death during an earthquake or other unforeseen incident. |
|  | Always connect power cable to appropriate facility outlet or terminal. |
| | Connect power cable to a suitable facility outlet or terminal, according to the electrical requirements. |
| | Power requirements DKN303: AC115V single-phase 50/60Hz rated current 7.5A (breaker capacity 15A) DKN403: AC115V single-phase 50/60Hz rated current 11A (breaker capacity 15A) DKN403: AC115V single-phase 50/60Hz rated current 12A (breaker capacity 15A) DKN613: AC220V single-phase 50/60Hz rated current 7.5A (breaker capacity 15A) |
| | Operational voltage range is $\pm 10\%$ of power rating, performance guarantee voltage range is $\pm 5\%$, and frequency is $\pm 1\%$ Check the line voltage on distribution board and properly evaluate whether to utilize a line being shared by other equipment. If unit is not activated by turning on ELB, take an appropriate course of action, such as connecting unit to a dedicated power source. Inserting multiple cords into a single outlet, using branch outlets or extension cords, may cause a drop in voltage, which may affect performance, resulting in failure to control or maintain proper temperature. |
|  | Install in a dry location. |
| | Install unit where it will be free from liquid spray and other moisture. Failure to do so may result in control mechanisms becoming wet, causing malfunction, electric shock and/or fire. |
|  | Install equipment in a well-ventilated place |
| | Install unit so that side and rear panel vents are unobstructed and allowed to sufficiently diffuse heat. Doing so may result in excessive temperatures inside the unit control panel, causing possible degraded CPU board performance, malfunction or fire. See "2. COMPONENT NAMES AND FUNCTIONS(P.11)" for the position of the vent. . |
|  | Initial operation |
| | When using the product for the first time, an unusual odor may occur if the product is heated to a high temperature. This is due to the decomposition of the binding material in the insulation, not equipment failure. It is recommended to run unit at the highest temperature before use. |

3. PRE-OPERATION PROCEDURES

Installation Precautions



Use optional stacking hardware for double stacking

Be sure to use stacking hardware (optional) when mounting unit on top of another, and do not stack up more than two units. In the event of an earthquake or other unforeseen incident, equipment may unexpectedly shift or fall, causing serious injury.

4. PRE-OPERATIVE PREPARATIONS

Installation method

Chamber Rack Placement

Install the chamber rack

- Do not remove the bottom-most rack secured with screws to chamber.
*There are sharp protrusions on the chamber interior, chamber rack, and rack support post, so be careful not to get injured.
In particular, working with bare hands is dangerous. Please wear gloves.

- ① Attach rack supports to the left and right support posts inside chamber in the desired height.

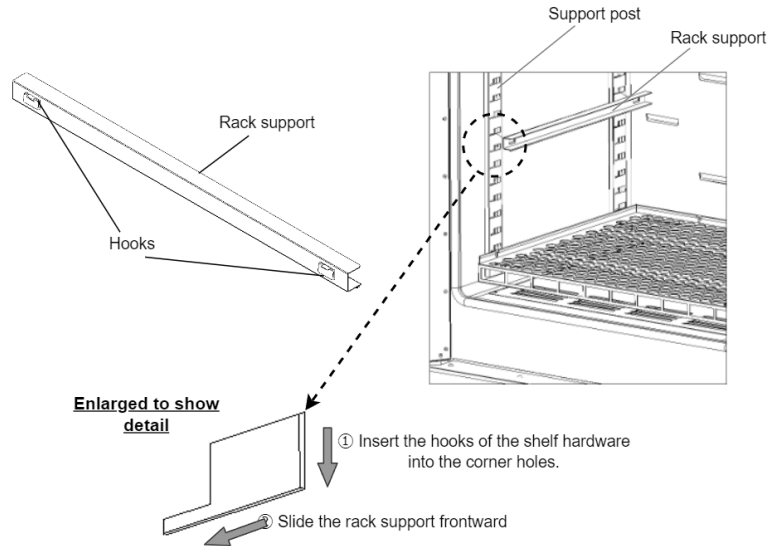

- ② Push and slide the rack to the end in chamber. Pay attention to the height of the left and right rack supports.
- ③ Make sure that the rack is properly in place and does not rattle or fall.

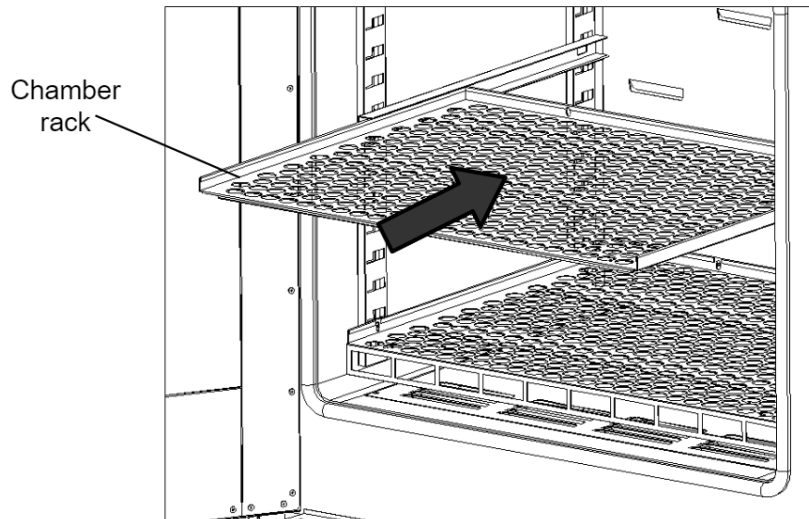

4. PRE-OPERATIVE PREPARATIONS

Installation method

How to set the samples



Chamber rack load capacity

The load capacity of the chamber racks is approximately 15 kg each, when load is evenly distributed. Test sample load total for each rack should not exceed this specification. Arrange test samples evenly on racks, leaving as much space between them as possible.

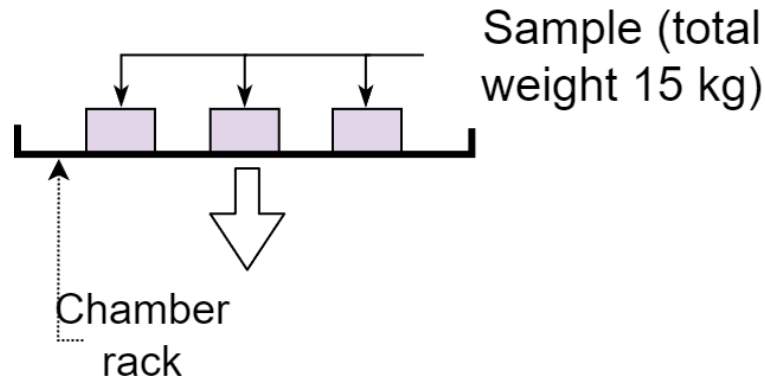

Sample placement

As a rule, use approximately 70% of entire rack space or less, when placing samples, to ensure better temperature control accuracy. Failure to do so may result in degraded temperature control performance or abnormal overheating.

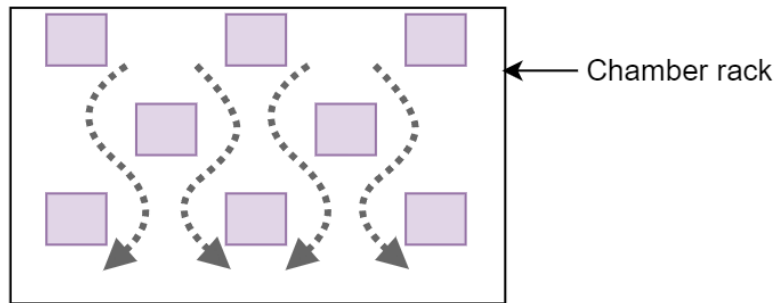



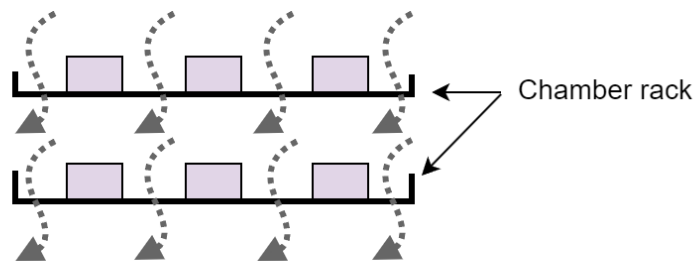

Leave 30% of total rack space empty



Be careful not to pack too much samples

4. PRE-OPERATIVE PREPARATIONS

Installation method

| | |
|---|--|
|  | DO NOT place items on bottom surface of chamber (diffuser panel). |
| | Be sure to place test samples on supplied racks, and do not remove screws from the bottom-most rack. Do not use the product with the sample directly on the bottom of the chamber (rectification plate). Not only will the product not perform well, but the temperature in the tank may become abnormally high or cause a malfunction. Always use the supplied chamber racks, supported on the standard rack supports, and avoid placing any items on bottom surface. Do not allow test samples to contact chamber walls. |
|  | DO NOT process corrosive items. |
| | Do not process items containing corrosive chemicals of any kind. Potent acids may corrode the reservoir despite stainless steel construction. |
|  | Exercise caution when processing heat-generating substances |
| | Note that temperature reading may not be consistent when processing heat-generating samples. |
|  | When processing wet samples, remove as much of the moisture as possible beforehand, and open the exhaust port. |
| | Failure to do so may cause the electrical system to be adversely affected due to excessive humidity rise, resulting in electrical leakage or equipment malfunction. It may also cause rust, corrosion, and condensation on the interior and exterior. Steam emitted from the exhaust port is hot. Do not look into or bring hands close to the exhaust port. |

4. PRE-OPERATIVE PREPARATIONS

Operation Modes and Functions

Operation modes for this unit are defined in the table below

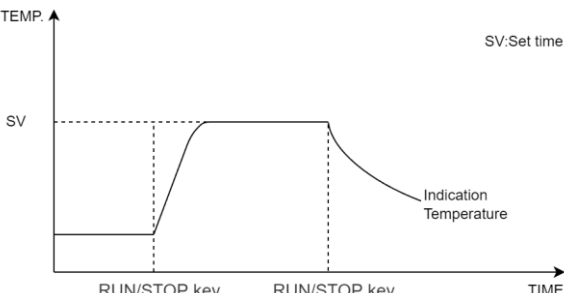
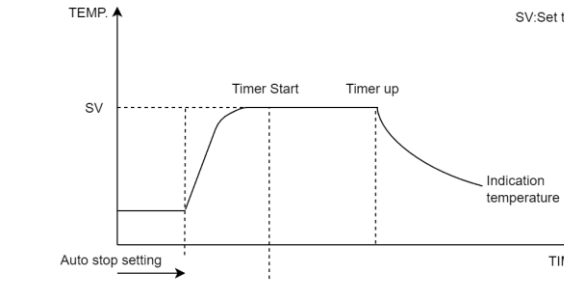
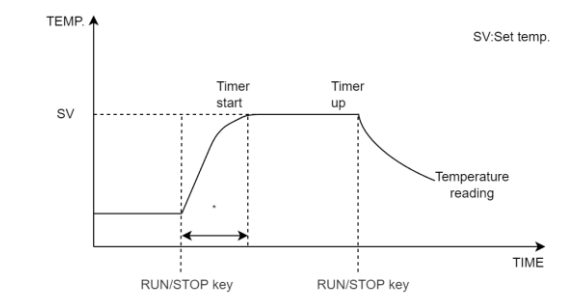
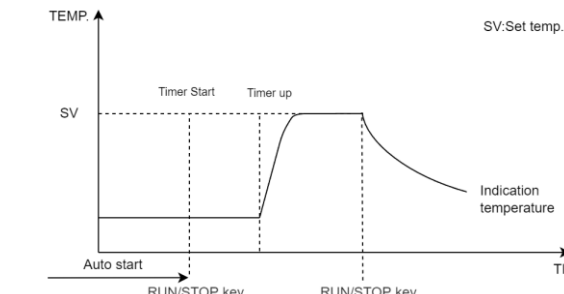
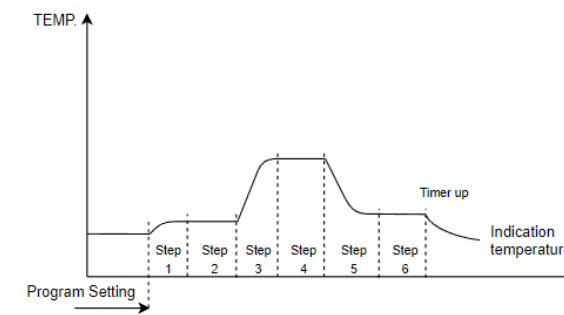
| № | Panel Item | Description |
|---|--|---|
| 1 | <p>Fixed temperature operation This mode runs unit at a constant selected temperature.</p> |  <p>The graph shows temperature (TEMP) on the y-axis and time (TIME) on the x-axis. A horizontal line at the bottom represents the initial temperature. A vertical dashed line marks the 'RUN/STOP key' press. The temperature curve rises to a set point (SV) and remains constant. A second vertical dashed line marks another 'RUN/STOP key' press. The temperature then gradually decreases, labeled as 'Indication Temperature'. The set point is labeled 'SV:Set time'.</p> |
| 2 | <p>Auto stop operation This mode is used to automatically terminate an operation when a specified time period has passed (decided before operation). Timer begins counting down when chamber temperature reaches the temperature setting, and operation stops automatically when timer reaches 0.00</p> |  <p>The graph shows temperature (TEMP) on the y-axis and time (TIME) on the x-axis. A horizontal line at the bottom represents the initial temperature. A vertical dashed line marks the 'RUN/STOP key' press. The temperature curve rises to a set point (SV) and remains constant. A vertical dashed line marks 'Timer Start'. The temperature remains constant until a second vertical dashed line marks 'Timer up'. The temperature then gradually decreases, labeled as 'Indication temperature'. The set point is labeled 'SV:Set temp'.</p> |
| 3 | <p>Quick Auto Stop Operation This mode is used to automatically terminate an operation when a specified time period has passed (decided during operation). Constant Temperature/Quick Auto Stop Operation</p> |  <p>The graph shows temperature (TEMP) on the y-axis and time (TIME) on the x-axis. A horizontal line at the bottom represents the initial temperature. A vertical dashed line marks the 'RUN/STOP key' press. The temperature curve rises to a set point (SV) and remains constant. A vertical dashed line marks 'Timer start'. The temperature remains constant until a second vertical dashed line marks 'Timer up'. The temperature then gradually decreases, labeled as 'Temperature reading'. The set point is labeled 'SV:Set temp.'. A note below the graph says '* Set during Fixed temp. operation'.</p> |
| 4 | <p>Auto start operation It is used when "I want to start the fixed value operation automatically after the set time". Fixed temperature operation will start after the time is up.</p> |  <p>The graph shows temperature (TEMP) on the y-axis and time (TIME) on the x-axis. A horizontal line at the bottom represents the initial temperature. A vertical dashed line marks the 'RUN/STOP key' press. The temperature remains constant for a period labeled 'Auto start'. Then, the temperature curve rises to a set point (SV) and remains constant. A vertical dashed line marks 'Timer Start'. The temperature remains constant until a second vertical dashed line marks 'Timer up'. The temperature then gradually decreases, labeled as 'Indication temperature'. The set point is labeled 'SV:Set temp.'. Another 'RUN/STOP key' press is marked on the x-axis.</p> |
| 5 | <p>Program operation This operation is used to run a combination of temperatures, times and modes as one operation. In the figure at right, the line pattern which indicates time variation of the set temperature is called "program", and each straight line which is a combination of set temperature and set time is called "step".</p> |  <p>The graph shows temperature (TEMP) on the y-axis and time (TIME) on the x-axis. A horizontal line at the bottom represents the initial temperature. A vertical dashed line marks the 'Program Setting' and 'RUN/STOP key' press. The temperature curve follows a series of steps: Step 1 (rise to a set point), Step 2 (constant temperature), Step 3 (rise to a higher set point), Step 4 (constant temperature), Step 5 (fall to a lower set point), and Step 6 (constant temperature). A vertical dashed line marks 'Timer up'. The temperature then gradually decreases, labeled as 'Indication temperature'.</p> |

4. PRE-OPERATIVE PREPARATIONS

Operation Modes and Functions

| | | |
|--|---|--|
| 6 | <p>Program operation auto start This mode is used to specify an automatic start time for constant temperature operation. Program operation will start after the time is up.</p> | |
| <p>*It is not possible to change modes during operation. If a mode change is required, operation must be terminated and a new mode of operation must be set.</p> | | |

Operation functions for this unit are defined in the table below:

| Operation mode | Description |
|---|--|
| <p>Overheat prevention device</p> | <p>This function is to prevent abnormal overheating of unit.</p> <ul style="list-style-type: none"> • Automatic overheat prevention function: This function is set to automatically activate when chamber temperature exceeds the temperature setting by 12 °C. Unit will restart heater control when chamber temperature comes within temperature setting +12 °C (Error code is not displayed) • Independent overheat prevention device (P.25) : When the temperature in the chamber reaches the set temperature of the independent over-temperature protection device, the heater energizing line is shut off, the abnormality lamp/ALARM lamp lights, and an error code is displayed. |
| <p>Calibration offset</p> <div style="border: 1px solid black; padding: 2px; display: inline-block; margin: 5px;">cAL</div> | <p>Calibration offset function is to compensate for differences in the temperature reading (as taken by unit sensor) and actual chamber temperature (as taken manually with a thermograph). Unit can be offset to either the positive or negative side of temperature line for entire temperature range of unit. The settings can be configured from SUB MENU.</p> |
| <p>Keypad lock</p> <div style="border: 1px solid black; padding: 2px; display: inline-block; margin: 5px;">Lock</div> | <p>This function locks all the keys that may change setting values. The settings can be configured from SUB MENU.</p> |
| <p>Auto-resume mode select</p> <div style="border: 1px solid black; padding: 2px; display: inline-block; margin: 5px;">Pon</div> | <p>A function that allows selection of "automatically resume operation" or "standby" when power is restored due to a power failure during operation. It is. Unit can begin operation again with the same settings (in memory) as before the power failure occurred. The settings can be configured from SUB MENU.</p> |

4. PRE-OPERATIVE PREPARATIONS

Operation and setting before operation

The following chart illustrates operation flow of Fixed temperature operation and timed operations.

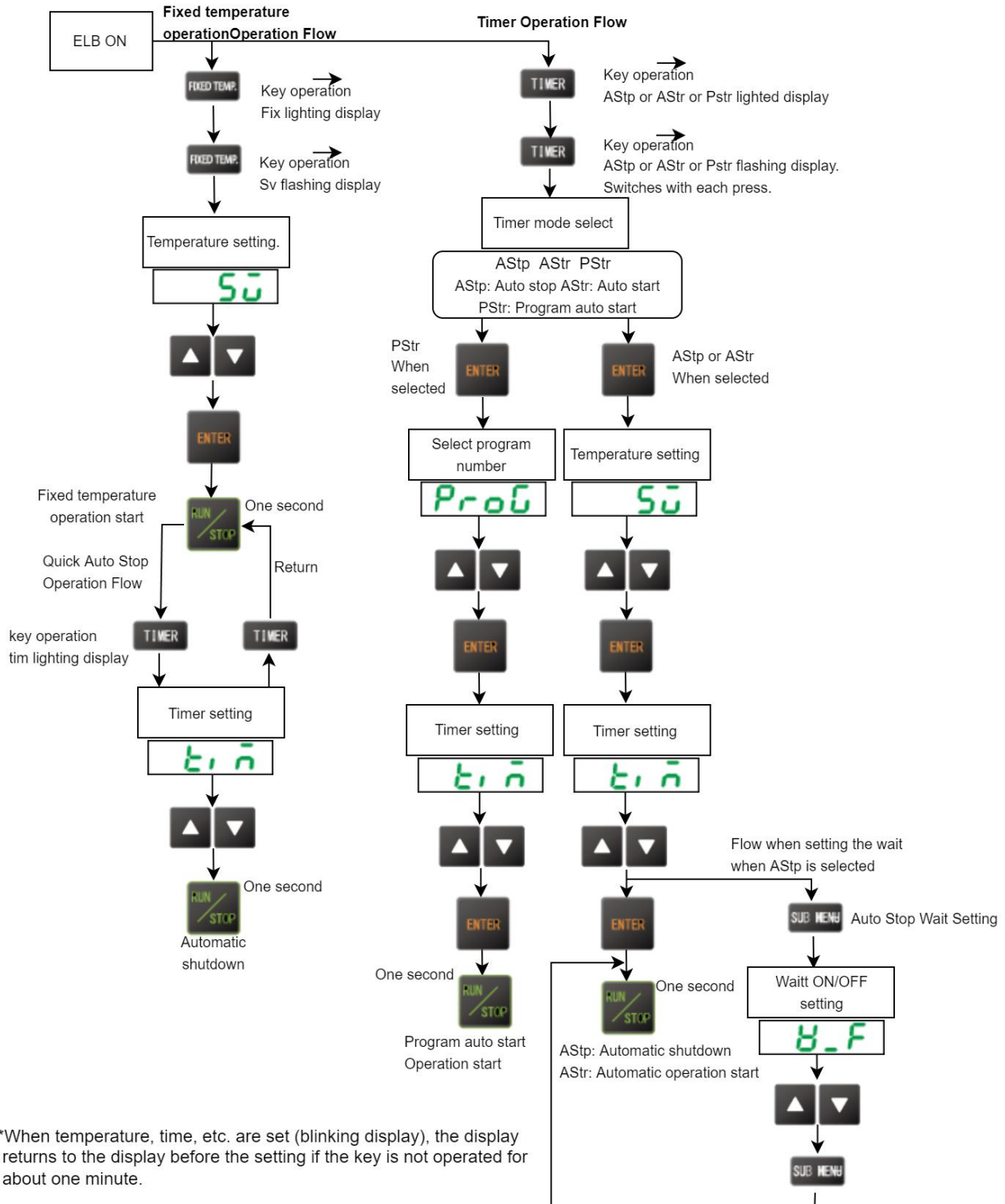

The following chart illustrates operation flow of Program operation and Submenu.

4. PRE-OPERATIVE PREPARATIONS

Operation and setting before operation

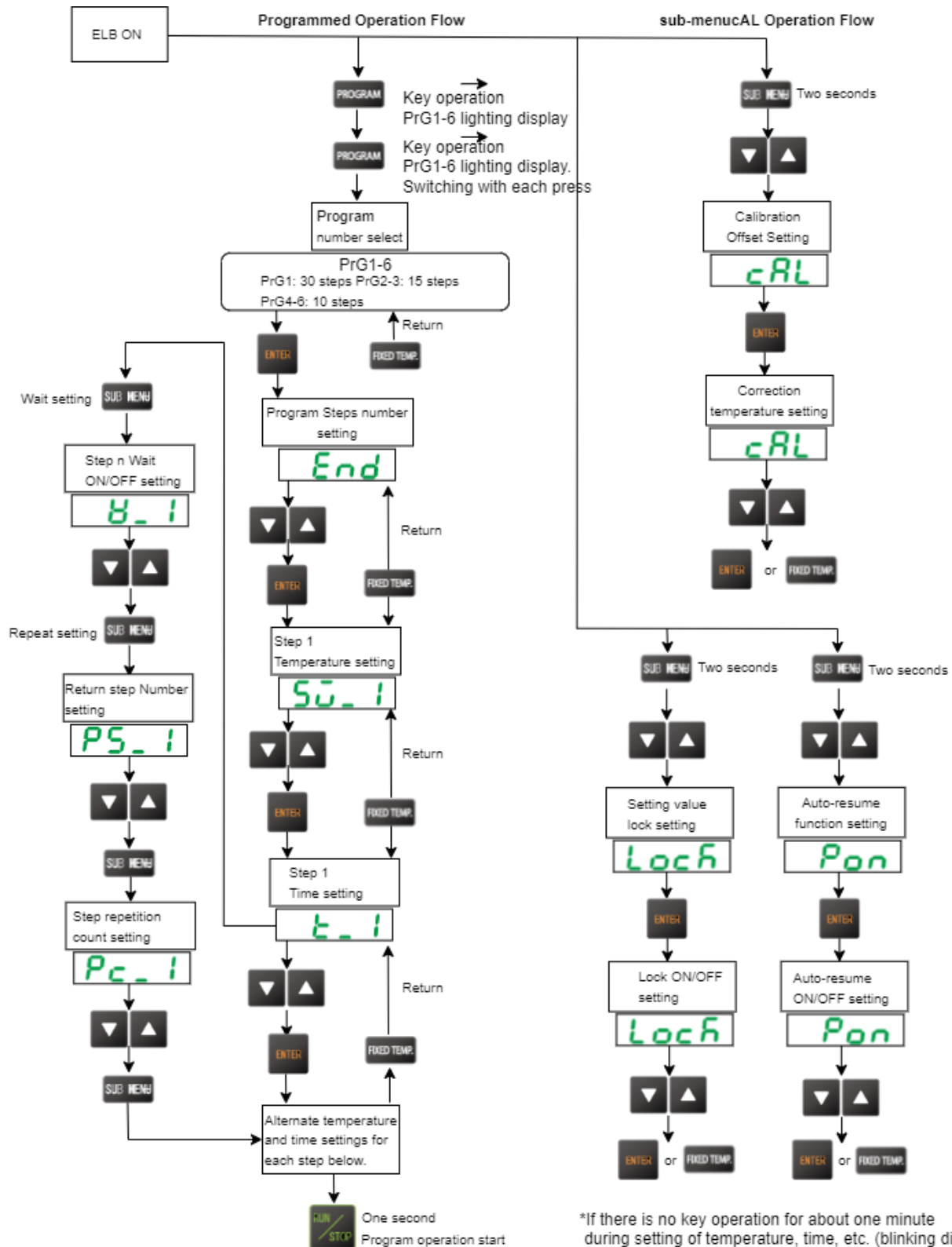

5. OPERATION PROCEDURES

Independent Overheat Prevention Device Setup

This unit features an independent overheat prevention device (manual reset) for a measure against overheating.

Setting range/function

The temperature setting range of independent overheat prevention device is from 50°C to 350°C. If the temperature near the heater continues to rise due to some abnormality and reaches the set temperature of the Independent overheat prevention device, the heater power supply is shut off, the abnormality lamp lights, the error code **E-07** is displayed, and a buzzer sounds. Once activated, error will not be cancelled unless earth leakage breaker is turned off, and then back on. (The buzzer sound disappears when any key is pressed.)

Readjust the temperature set point of the independent over temperature protection device to the proper temperature, turn the breaker "OFF ", and then turn it "ON " again.

Set temperature for independent overheat prevention device

- Turn the dial of independent overheat prevention device to align a temperature scale with the mark. (Refer to the figure below)

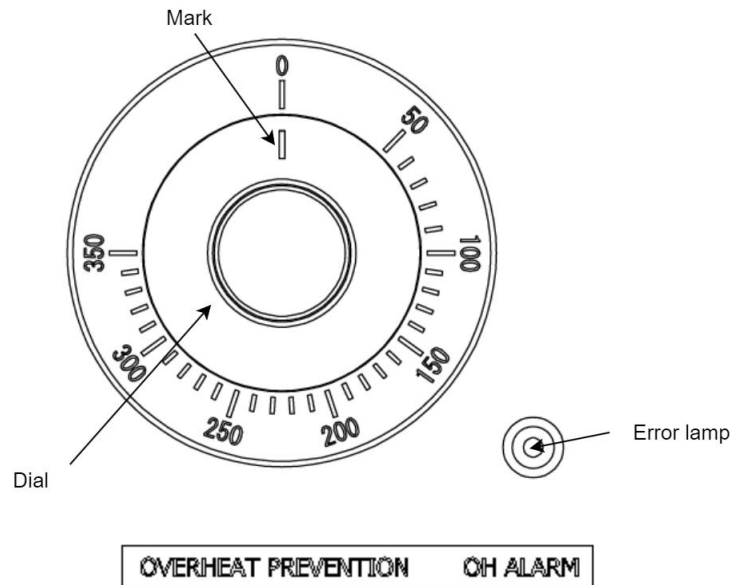

CAUTION

- ① The temperature setting of the independent overheat prevention device should be set based on the value added to the operating set temperature listed for each operating temperature range below.

Operating set temperature 40 to 150°C: set temperature +40°C

151-200°C: set temperature +50°C

201-260°C: set temperature +60°C

If the above settings malfunction, add about 10°C (1 graduation).

- ② Independent overheat prevention device sensor is installed near the heater to detect overheat errors due to malfunctions, etc. as soon as possible. Since the temperature near the heater is higher than the temperature inside the chamber, the temperature setting of the independent overheat prevention device is set to a higher value. For the position of the sensor of the independent over speed protector, please refer to P12 Components.
- ③ The independent over speed protector has a characteristic of fluctuating operating temperature depending on the room temperature, so a margin setting is required.

5. OPERATION PROCEDURES

- ④ If air circulation is obstructed due to overloading of samples, etc., the independent overload preventer may be activated. In this case, reduce the amount of samples to secure enough space, and rearrange samples as uniformly as possible.
- ⑤ Operation may be terminated by independent overheat prevention device activation, when independent overheat prevention device temperature setting is lower than it should be.
- ⑥ The overheating protector is not intended to protect the sample, but to protect the product. Prevents burning and harm to the human body in the unlikely event that the unit abnormal overheats. In addition, it does not protect accidents in the use of explosive or flammable substances.

5. OPERATION PROCEDURES

Fixed temperature operation

Setting temperature for overheat prevention

1. Turn on the power. (Turn the breaker ON)

When the power is turned on, the initial value is displayed for about 5 seconds, then the initial setting screen is displayed, and the current measured temperature and operation mode character are displayed on each display unit.

*1 Temperature reading display: Shows current temperature in the bath and other setting information

*2 Temperature setting display: Shows temperature setting and other setting information

See "[Display Characters](#)(P.14)" for information on operation mode characters. See the timing diagram below.



2. Select operation mode

① Press **FIXED TEMP.**. **F.11** appears on temperature setting display



5. OPERATION PROCEDURES

Fixed temperature operation

3. Set the temperature

② Press **FIXED TEMP.** again.

50 appears on the temperature reading display, the current set temperature blinks on the temperature setting display, and the **FIXED TEMP.** lamp blinks.

③ Use **▲** **▼** to set the desired temperature.

④ Press **ENTER** to complete the setting.



4. Start operation.

⑤ Press **RUN/STOP** for about one second. Operation is started and the **FIXED TEMP.** lamp illuminates.

5. Stop operation.



⑥ Press **RUN/STOP** for about one second. Operation is stopped, the **FIXED TEMP.** lamp goes out, and the display switches to the pre-operation screen.







5. OPERATION PROCEDURES

Fixed temperature operation

◆Setpoint loop function

When setting temperature  or  time by the or key, the setting value cycles in the setting range; when it reaches the maximum settable value, it returns to minimum and goes up again.

◆Editing and confirming settings

Changing Temperature during operation is possible by pressing the  key. Use the   to change the setting values. Press the  when changes have been entered.

5. OPERATION PROCEDURES

Quick Auto Stop Operation

Quick auto stop operation procedure

This function performs auto-stop operation during constant value operation.

1. Set timer during Fixed temperature operation

- ① Make sure that constant value operation is in progress (FIXED TEMP. lamp is lit) and press

TIMER.

ti n appears on the temperature reading display and the current setting time blinks on the temperature setting display.

At this point, press **TIMER** again to return to the constant value operation display.

- ② Set the timer using the   s.



5. OPERATION PROCEDURES

Quick Auto Stop Operation

2. Start timed operation

- ③ Press  for about one second after setting timer. The FIXED TEMP. and AUTO STOP lamps light to start timer operation.

3. To terminate auto start operation

- ④ Operation stops automatically when timer reaches 0.00. A buzzer sounds for approximately 5 seconds to notify the user when the machine stops. At this time,  is displayed on the temperature setting display with the FIXED TEMP. and AUTO STOP lamps lit.

Press  for about 1 second to exit the timer operation mode. Switches to the screen before constant value operation.

Pressing  for about one second during operation will terminate operation and the displays will return to initial settings screen.



5. OPERATION PROCEDURES

Quick Auto Stop Operation



◆Wait mode for Quick auto stop operation



Before operation, please check whether  described in the next section "Auto Stop Operation" is set to "oFF" or "on".





With this function "on", timer stops counting down when temperature reading goes out of the range of target temperature ± 3 °C, and resumes counting when it comes within the range again.

When set to "oFF", timer begins counting from the start of Quick auto-stop operation, and continues counting regardless of the deference between temperature reading and temperature setting.

◆Editing or confirming settings

Changing Temperature during operation is possible by pressing the  key. Use the 

 to change the setting values. Press the  when changes have been entered.



To change the set time during operation, press  to change the time. Use the   to change the setting values. Press the  when changes have been entered.

Note that the time which has already elapsed will be subtracted from the new setting.

Press  at any time during operation to see temperature setting, setting mode and remaining time in the temperature setting display.

◆Timer function

Maximum value for timer is "999 hours and 50 minutes". Units are from 0 minutes to 99 hours and 59 minutes in increments of 1 minute.

100 to 999 hours and 50 minutes are set in 10-minute increments. When   are held down,

values advance perpetually. Press   repeatedly for incremental adjustment.

***This is common to all the operation modes except for Fixed temperature mode.**

5. OPERATION PROCEDURES

Auto stop operation

Auto stop operation procedure

Used when "automatic shutdown is desired after a set period of time has elapsed since the set temperature was reached".

1. Set stop time

- ① Press **TIMER** from the initial screen state. Mode used in the previous session will be shown in the temperature setting display.
- ② Press **TIMER** again and center display will begin flashing. Each time you press **TIMER**, the timer mode is switched to select **ASLP**. At this time, the AUTO STOP and FIXED TEMP. lamps flashing.
- ③ Press **ENTER**.



- ④ **50** appears on the temperature reading display and the current setting time blinks on the temperature setting display.

Set temperature using



- ⑤ Press **ENTER**.

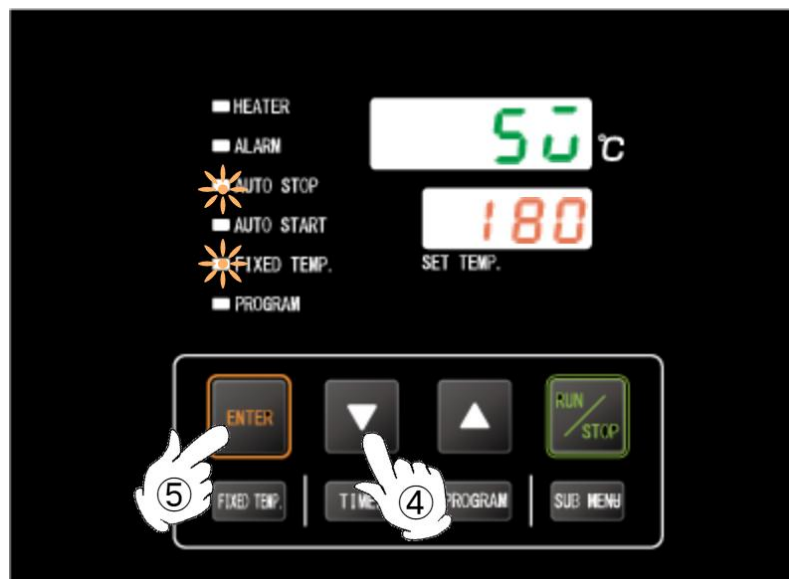

5. OPERATION PROCEDURES

Auto stop operation

- ⑥ t.n appears on the temperature reading display and the current setting time blinks on the temperature setting display.

Set the timer using



- ⑦ Press SUB MENU.



- ⑧ u.F is displayed on the temperature reading display and off or on is displayed on the temperature setting display.

Press



to set the weight off or on.

1. The default setting is "on".

- ⑨ Press SUB MENU to complete the setting.

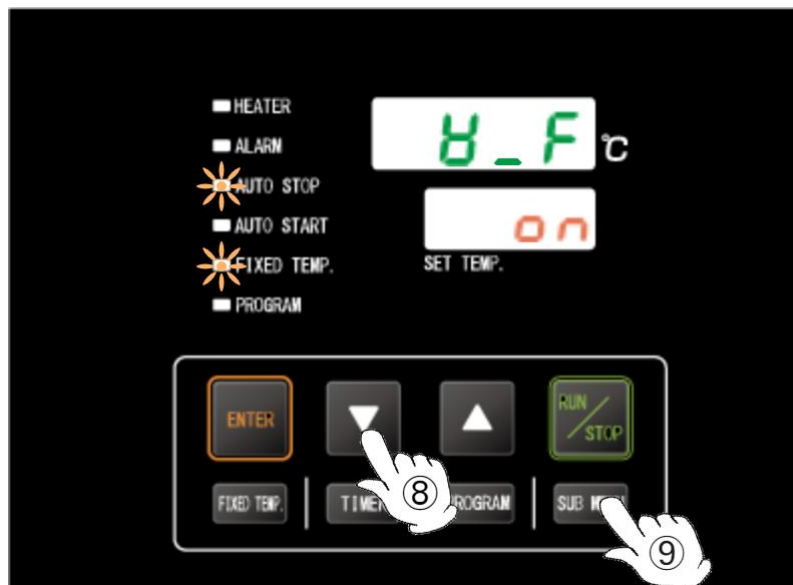

*Wait setting can be skipped by pressing ENTER after STEP ⑥.

5. OPERATION PROCEDURES

Auto stop operation

◆Wait mode for Auto stop operation

When 8_F is set to "on", the timer stops counting for the set time from the point when the measured temperature reaches the set temperature, and resumes counting when the temperature returns to within the $\pm 3^{\circ}\text{C}$ range.

When set to "oFF", timer continues counting regardless of the deference between temperature reading and temperature setting.

* The default setting is "on".

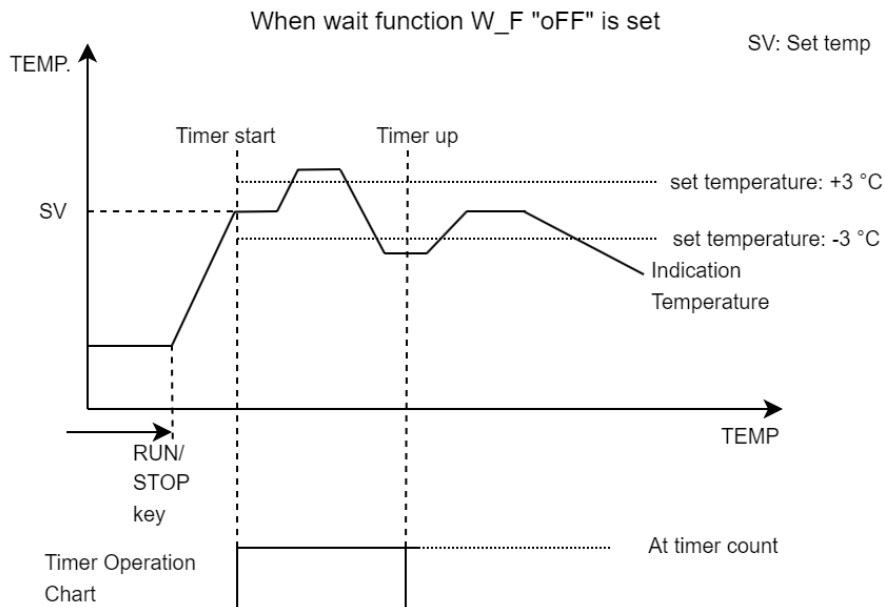
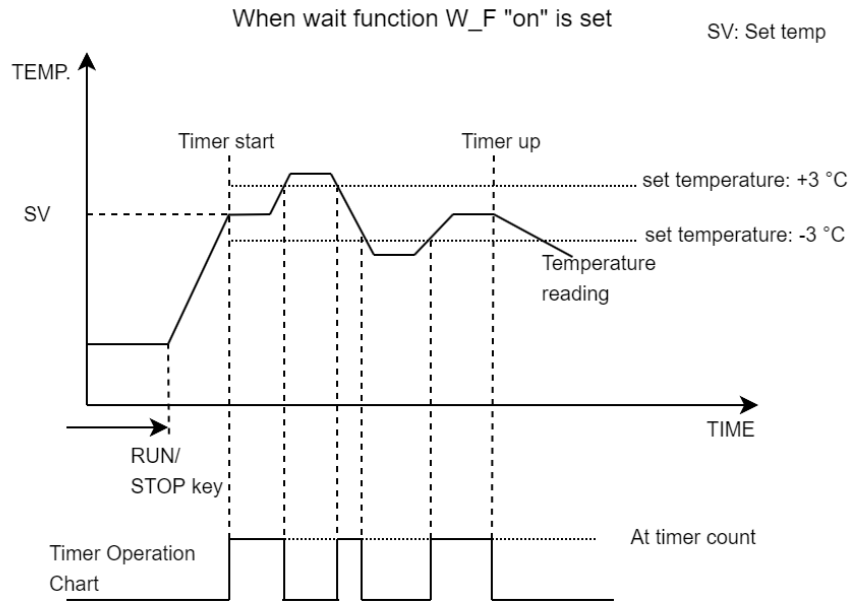



5. OPERATION PROCEDURES

Auto stop operation

2. Start operation

- ⑩ After setting the desired time, etc., press  for about one second. Operation starts and the AUTO STOP and FIXED TEMP. lamps light up. Timer begins counting down when chamber temperature reaches the set temperature.





3. Stop operation

- ⑪ Operation is automatically stopped after the set time has elapsed. A buzzer sounds for approximately 5 seconds to notify the user when the machine stops. At this time,  is displayed on the temperature setting display with the FIXED TEMP. and AUTO STOP lamps lit. Press  to finish Auto stop operation. Displays will return to initial settings screen.

Pressing  for about 1 second during operation will terminate operation and the displays will return to initial settings screen.



◆Editing or confirming settings

To change the set temperature and time during operation, press  while the unit is in operation, then press , then press   for the temperature and time setting operation for auto stop operation, and then press  respectively. Note that the time which has already elapsed will be subtracted from the new setting.

Press  at any time during operation to see temperature setting, operation mode and remaining time in the temperature setting display. When the remaining time dot is blinking, it indicates that the timer is counting. When the dot is lit, it indicates that the temperature is rising or falling and the measurement temperature is waiting to reach the set temperature.

5. OPERATION PROCEDURES

Auto start operation

Auto start operation procedure

1. Set start time

① Press **TIMER** from the initial screen state. Mode used in the previous session will be shown in the temperature setting display.

② Press **TIMER** again and center display will begin flashing.

Each time you press **TIMER**, the timer mode is switched to select **AStr**. At this time, the AUTO START lamp and FIXID TEMP. lamp blink.

① Press **ENTER**.

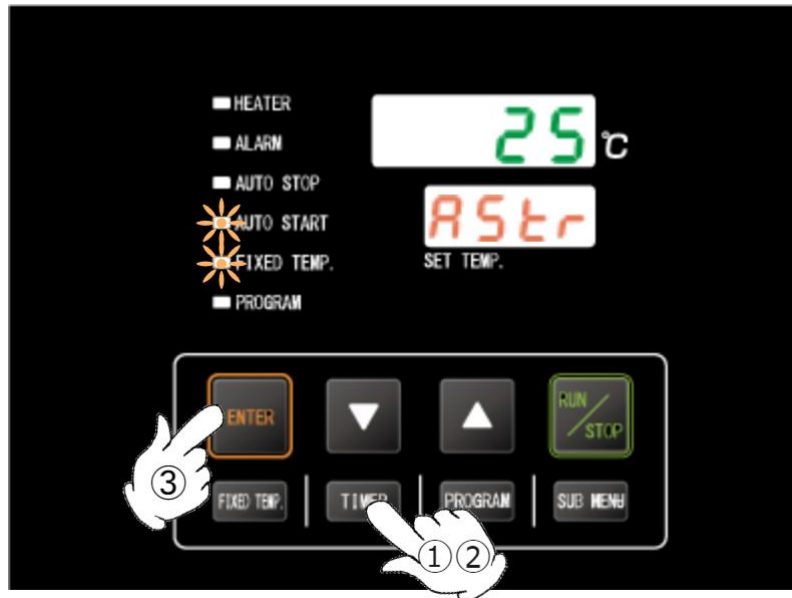

④ **50** appears on the temperature reading display and the current temperature setting blinks on the temperature setting display.

Set the timer using **▲** **▼**.

⑤ Press **ENTER**.

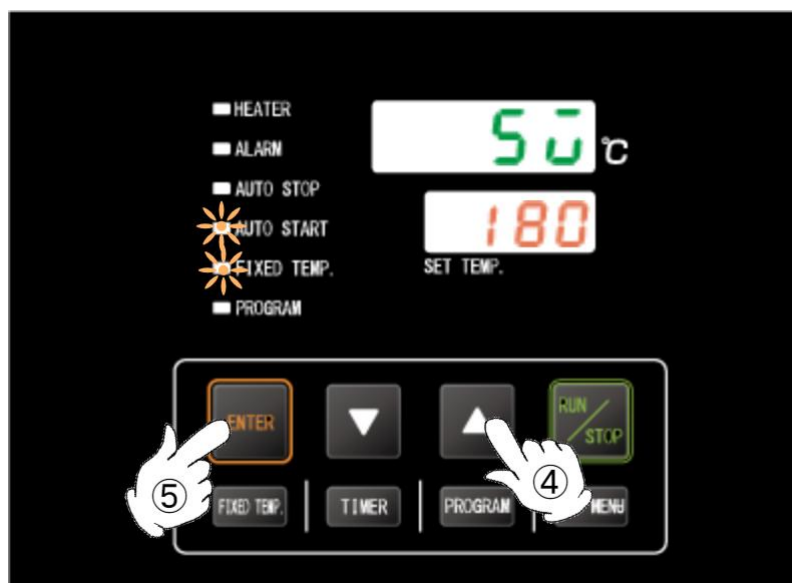

5. OPERATION PROCEDURES

Auto start operation

- ⑥  appears on the temperature reading display and the current setting time blinks on the temperature setting display.

Set the temperature using



- ⑦ Press  to complete the setting.



2. Start of operation

- ⑧ After setting the desired temperature, press  for about one second. Operation starts and the AUTO START and FIXED TEMP. lamps light up. After the set time has elapsed, the constant value operation starts automatically.

3. Stop operation





- ⑨ Press  for approx. one second. Operation is stopped, the FIXED TEMP. lamp goes out, and the display switches to the pre-operation screen.



5. OPERATION PROCEDURES

Auto start operation

◆Editing or confirming settings

To change the set temperature and set time during operation, press  while the unit is in operation, then press , then press   for the temperature and set time operations for auto start operation, and then press  for each.

Note that the time which has already elapsed will be subtracted from the new setting. Setting change made after operation has begun will not apply to the currently running operation.

Press  at any time during operation to see temperature setting, setting mode and remaining time in the temperature setting display.

5. OPERATION PROCEDURES

Program operation auto start

Run a Program auto start operation

1. Set start time

For program settings, refer to "[Building Programs\(P.45\)](#)" and set them in advance.

- ① Press **TIMER** from the initial screen state. Mode used in the previous session will be shown in the temperature setting display.
- ② Press **TIMER** again and center display will begin flashing.

Each time you press **TIMER**, the timer mode is switched to select **PStt**. At this time, the AUTO START and PROGRAM lamps blink.

- ③ Press **ENTER**.



- ④ **Prog** appears on the temperature reading display and one of PrG1 to 6 blinks on the temperature setting display.

Select program number to set Auto start mode by using **UP** and **DOWN**.

- ⑤ Press **ENTER**.



5. OPERATION PROCEDURES

Program operation auto start

- ⑥  appears on the temperature reading display and the current setting time blinks on the temperature setting display.

Set the timer using



- ⑦ Press  to complete the setting.





5. OPERATION PROCEDURES

Program operation auto start

2. Start of operation





- ⑧ After setting the desired temperature, press  for about one second. Operation starts and the AUTO START lamp and PROGRAM lamp light up. Programmed operation starts automatically when the set time elapses.

3. Stop operation

- ⑨ A buzzer sounds for about five seconds when operation ends.  is displayed on the temperature setting display. Press  to finish Program operation. Displays will return to initial settings screen. Pressing  for about 1 second during operation will terminate operation and the displays will return to initial settings screen.



◆Editing or confirming settings

To change the set time during operation, press  while the unit is running, then press  twice, then perform the time setting operation with  , then press . Note that the time which has already elapsed will be subtracted from the new setting.

Setting change made after operation has begun will not apply to the currently running operation.

Press  at any time during operation to see temperature setting, operation mode and remaining time in the temperature setting display. Displayed temperature setting is for Auto start operation.

5. OPERATION PROCEDURES

Program operation

Program operation

This operation is used to run a combination of temperatures, times and modes as one operation. In the figure below, the line pattern which indicates time variation of the set temperature is called "program", and each straight line which is a combination of set temperature and set time is called "step".

◆ Program Type

Up to 6 program types can be set. Each program can include steps as shown below

| | |
|------|--|
| PrG1 | A Program pattern using up to 30 steps can be entered. |
| PrG2 | Program patterns using up to 15 steps can be entered. |
| PrG3 | |
| PrG4 | |
| PrG5 | Program patterns using up to 10 steps can be entered. |
| PrG6 | |

Example

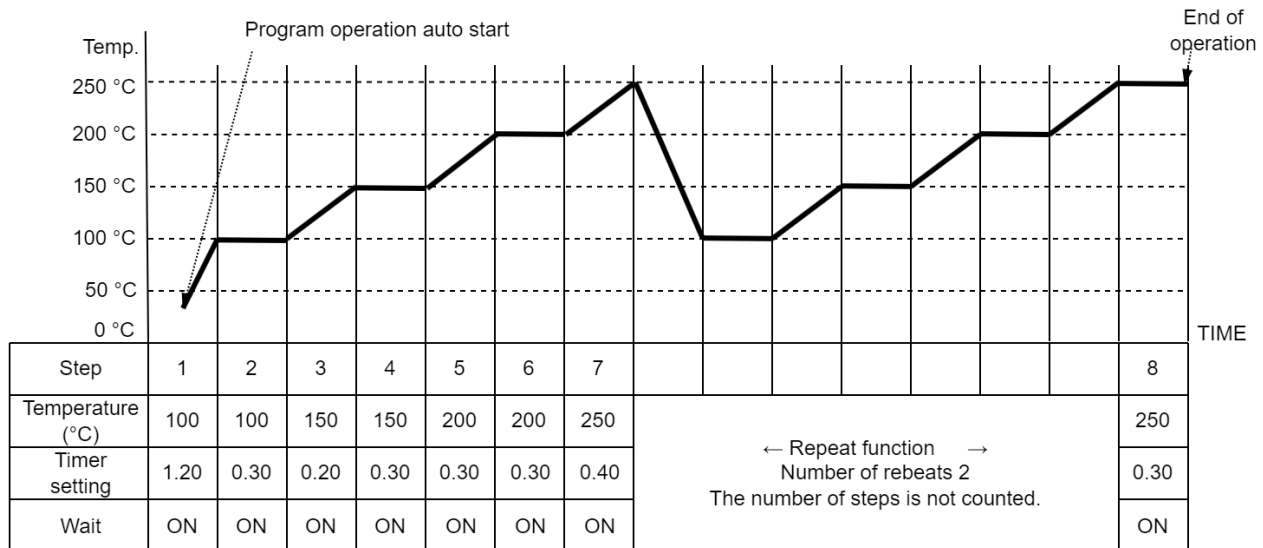

◆ program before setting up the program

Enter program patterns before attempting to run a programmed operation.

- ⑥ Check the number of steps, temperature and time for each step of the program to be created in advance using the "[Program Planning Worksheet\(P.57\)](#)" in the instruction manual.
- ⑦ Check the temperature rise and fall capability of the unit. The time setting must be made within the temperature rise and fall capabilities of the unit.
For example, if unit is capable of increasing or decreasing temperature by 50 °C in 10 minutes, approximately 20 minutes will be needed to increase or decrease temperature by 100 °C from a given temperature.
- ⑧ Check to see if there is an available program that satisfies the number of steps in the program to be set up. For example, for programs that require 20 steps, only PrG1 is applicable. However, steps using the repeat function are not counted.

5. OPERATION PROCEDURES

Program operation

◆Useful function

The repeat function is a convenient feature that can be used, when a series of steps, identical to ones already created, are needed to fill the remainder or remaining part of a program pattern. See "[About the Repeat Function](#)(P.55)" for details on how to use this function.

◆DKN type temperature rise / fall times

Temperature rise/fall time for DKN series models are as shown below. Numeric values signify time needed (in minutes) for temperature to rise or fall. [Example: DKN603 needs approximately 30 minutes to increase from 100 °C to 150 °C]. Temperature stabilization time is an added factor and not included in the table below. Be sure to conduct a test run before finalizing program pattern times.

Conditions: room temperature 23 °C, no load, exhaust port closed (unit: minute)

| | DKN303 | | DKN403 | | DKN603 | | DKN613 | |
|---|--------------------|---------------------|--------------------|---------------------|--------------------|---------------------|--------------------|---------------------|
| | Rise | Fall | Rise | Fall | Rise | Fall | Rise | Fall |
| 260 (250) °C ※ DKN603: 250 °C | Approx. 40 min. | Approx. 30 min. | Approx. 50 min. | Approx. 35 min. | Approx. 45 min. | Approx. 25 min. | Approx. 65 min. | Approx. 40 min. |
| 200 °C | Approx. 25 min. | Approx. 30 min. | Approx. 25 min. | Approx. 30 min. | Approx. 35 min. | Approx. 30 min. | Approx. 40 min. | Approx. 35 min. |
| 150 °C | Approx. 25 min. | Approx. 45 min. | Approx. 25 min. | Approx. 50 min. | Approx. 30 min. | Approx. 60 min. | Approx. 30 min. | Approx. 50 min. |
| 100 °C | Approx. 20 min. | Approx. 65 min. | Approx. 25 min. | Approx. 85 min. | Approx. 30 min. | Approx. 90 min. | Approx. 25 min. | Approx. 80 min. |
| 50 °C | Approx. 10 min. | Approx. 160 min. | Approx. 15 min. | Approx. 225 min. | Approx. 15 min. | Approx. 365 min. | Approx. 15 min. | Approx. 130 min. |

5. OPERATION PROCEDURES

Program operation

Building Programs

The program pattern below will be used as an example for building programs

Program Pattern Reference Example

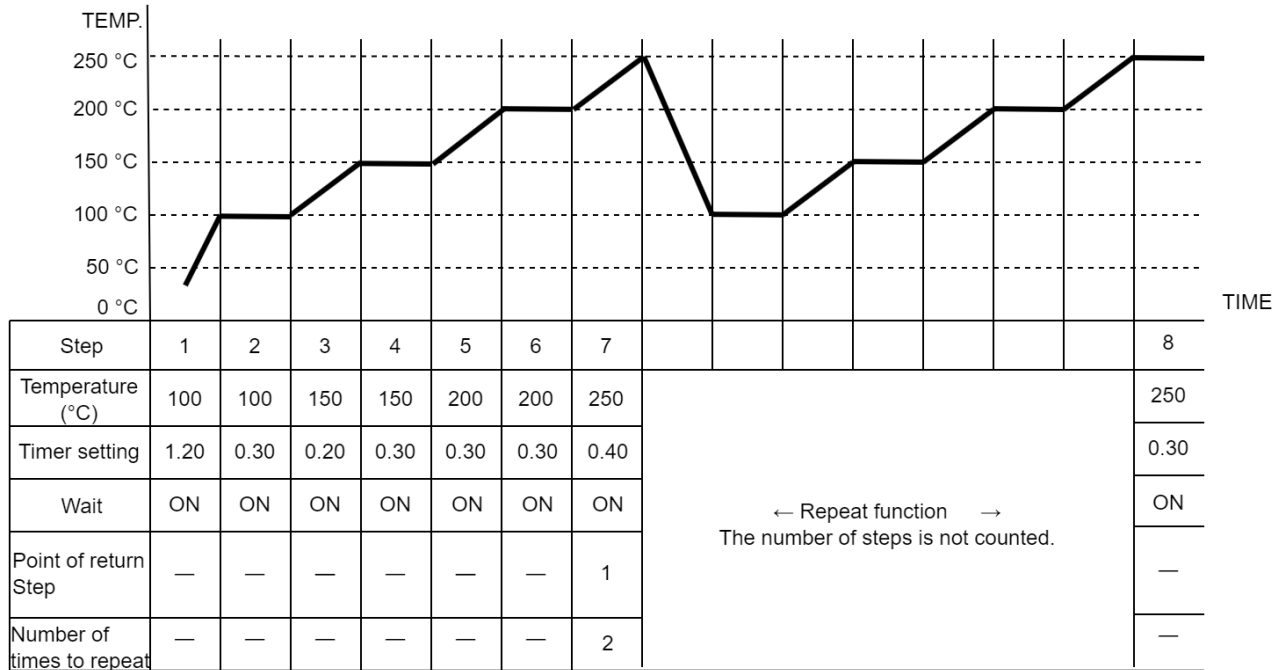

1. Select a program number.



- ① Press **PROGRAM**. The last used program number (e.g. PrG1) is illuminated on the temperature setting display.
- ② Press **PROGRAM** again, and the program number will blink. Press **PROGRAM** repeatedly to select a program number to edit. PROGRAM lamp will begin flashing.





5. OPERATION PROCEDURES

Program operation

2. Enter program

- ③ Press .  appears on the temperature reading display and the number of steps set on the temperature setting display blinks.



*Program steps can be set up to 30 steps for PrG1, 15 steps for PrG2 and PrG3, and 10 steps for PrG4 to PrG6. For the reference example program, use 8 steps. It can be set by selecting any program number from PrG1 to PrG6.



- ④ Enter the total number of steps to use, using the  .

*  is a character that represents the total number of steps to use. In the reference example, "8" will be set.



Enter the number of steps, temperature and time for each step (use the program planning worksheet).



- ⑤ Press .  is displayed to indicate the temperature setting for the first step, and the current temperature setting blinks.

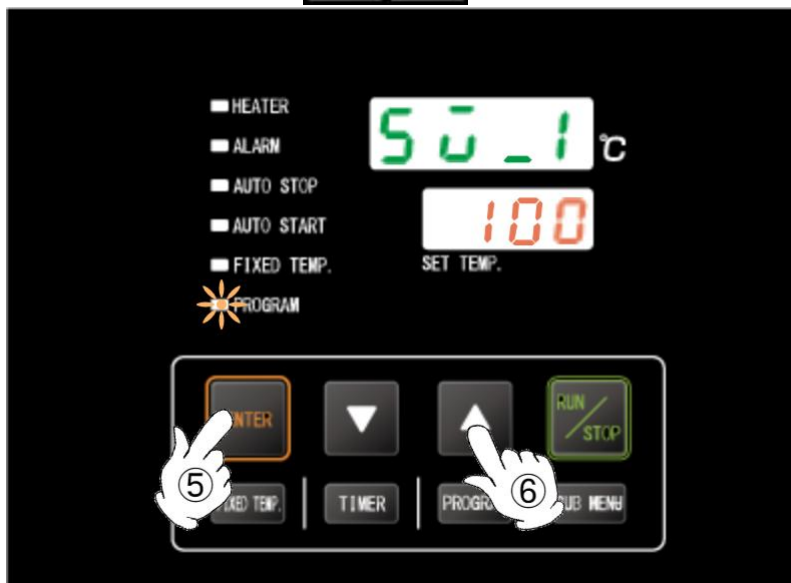

- ⑥ Set the temperature for the first step at  .



5. OPERATION PROCEDURES

Program operation



⑦ Press .  is displayed to indicate the setting time for the first step, and the current setting time blinks.

⑧ Set the temperature for the first step at  .

* Before setting the timer, be sure to confirm temperature rise/fall capability of unit.

Enter "0.00" to allow temperature to rise or fall in the shortest time. In the reference example, "1.20" is set. Be sure to set Wait for the corresponding steps to "on" Default setting is "on" for all steps. See "[Wait Function\(P.51\)](#)" for setting instructions.

Maximum timer setting for each step is 999 hours and 50 minutes.

⑨ When timer is set, press . The set temperature for the second step  will be displayed. Enter temperature and time using the same procedure, described thus far, for all steps (use the program planning worksheet). Display returns to the initial settings screen after setting temperature and timer in the final step.



5. OPERATION PROCEDURES

Program operation

If you want to repeat (repeat) a program pattern in the middle of a program, as in the reference example, a special operation is required. In this case, after setting the time (t_7 in the reference example) for the step (step 7 in the reference example) for which repeat operation is desired, press

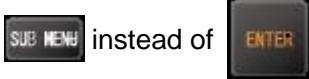

See "[About the Repeat Function\(P.55\)](#)" for how to set the repeat function.

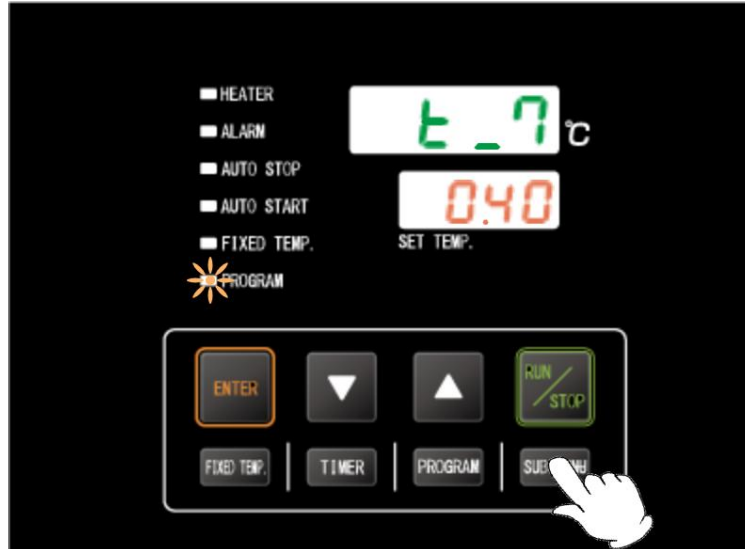



◆Verification run

Confirm temperatures and times in a newly entered program by running program with unit unloaded once, before using program on actual test samples.

3. Run Program operation

⑩ Press  for approx. one second. Selected program will begin running. PROGRAM lamp

illuminates and the temperature setting display will show , signifying that step 2 is currently under way.

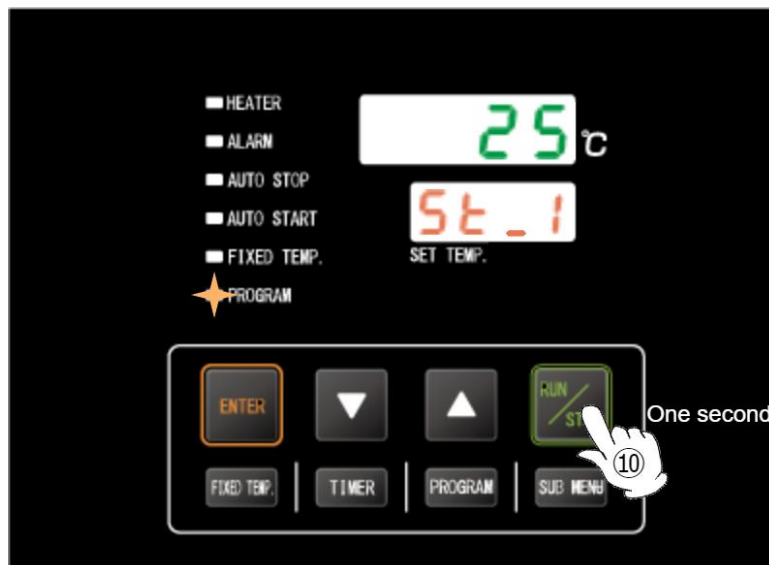

*Press  during operation to check the set temperature and remaining time for each step on the temperature setting display. When the remaining time dot is blinking, it indicates that the timer is counting. When the dot is lit, it indicates that the timer is waiting (temperature is rising or falling to the temperature setting) and the timer count has ended.



5. OPERATION PROCEDURES

Program operation

4. End of operation

- ⑪ A buzzer sounds for about five seconds when program ends.  is displayed on the temperature setting display. Press  for about 1 second to exit the program operation mode and switch to the pre-operation screen. Pressing  for about one second during operation will terminate operation and the displays will return to initial settings screen.



◆The setting time for each step

Maximum timer setting for each step is 999 hours and 50 minutes. The time can be set in increments of one minute under 99 hours and 59 minutes, and ten minutes after 100 hours.

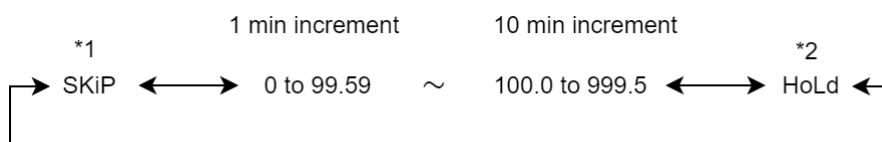

See the following instruction for *1 SKiP and *2 HoLd.



When   are held down, values advance perpetually.

Press repeatedly for incremental adjustment.

◆Step skip function*1

This function is to skip processing program steps. This setting can be made on each step. Select steps to skip by following the procedure below. Selected steps will be canceled and program will proceed to next step.

Referring to step ⑧ in "2. Program Settings," select the setting time t_n (n : step number) for the step for which you wish to make the skip setting. Set the current setting time to "0" minutes when it flashes,

press  once to select , then press .

5. OPERATION PROCEDURES



Program operation

◆Step hold function*2

This function is to continue operation with the settings of the selected step. This setting can be made on each step. Select steps to hold by following the procedure below. Unit will keep running the selected hold.

Referring to step ⑧ in "2. Program Settings," select the setting time t_n (n : step number) for the step for which you wish to make the hold setting. Set the current setting time to "0" minutes when it flashes,

press  twice to select , then press .

* Pressing  while unit is running a step in hold mode will show  in center display, indicating the step is set to hold.

◆To return to the previous step while building or checking programs

Press  to return to the previous step. However, it is not possible to return to the previous screen while the wait or repeat functions are being set.



5. OPERATION PROCEDURES

Wait Function

Wait Function

Wait mode for Program operation is to prevent operation to proceed next step, or to pause timer count while chamber temperature is outside the range of target temperature ± 3 °C.

This setting can be made on each step.

Wait setting W_n (n: step number) When  is set "on", the set temperature has priority.

When shifting from one step to the next step, if the step's set time expires but the measured temperature is outside the range of ± 3 °C relative to the set temperature, the next step will not be taken. Unit will go on to next step when the temperature comes within the range of target temperature ± 3 °C

Timer stops counting down when temperature reading goes out of the range of target temperature ± 3 °C, and resumes counting when it comes within the range again.

When "oFF" is set, priority is given to the set time. Even if the measurement temperature is outside the range of ± 3 °C from the set temperature, the next step is performed as soon as the time set for the step expires.

5. OPERATION PROCEDURES

Wait Function

When wait function W_n "on" is set of each step

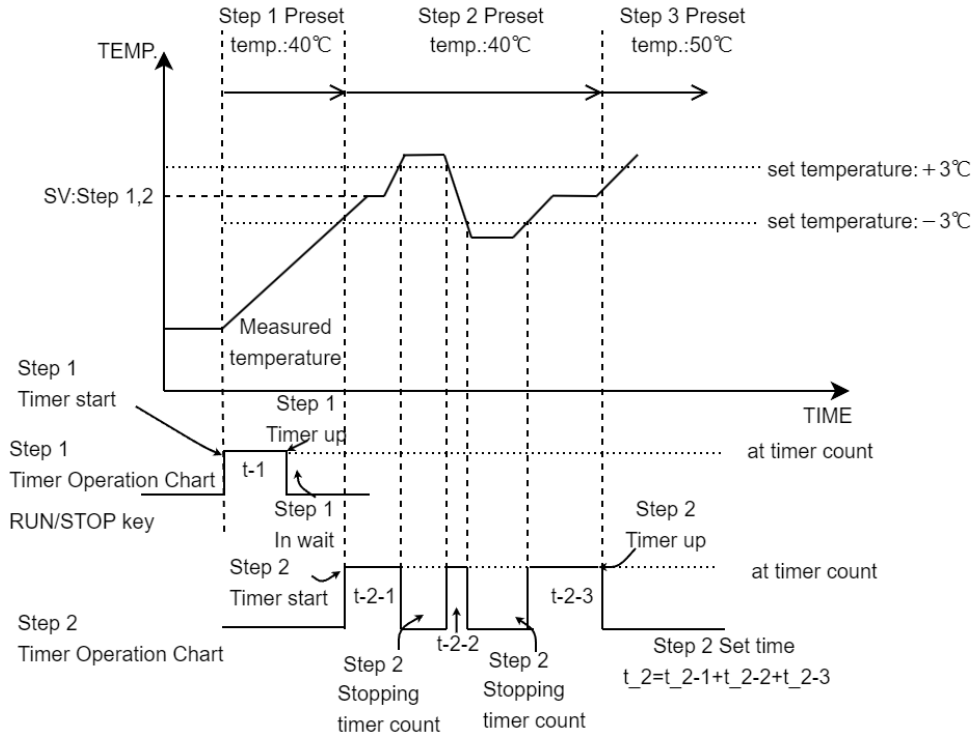

When wait function W_n "oFF" is set of each step

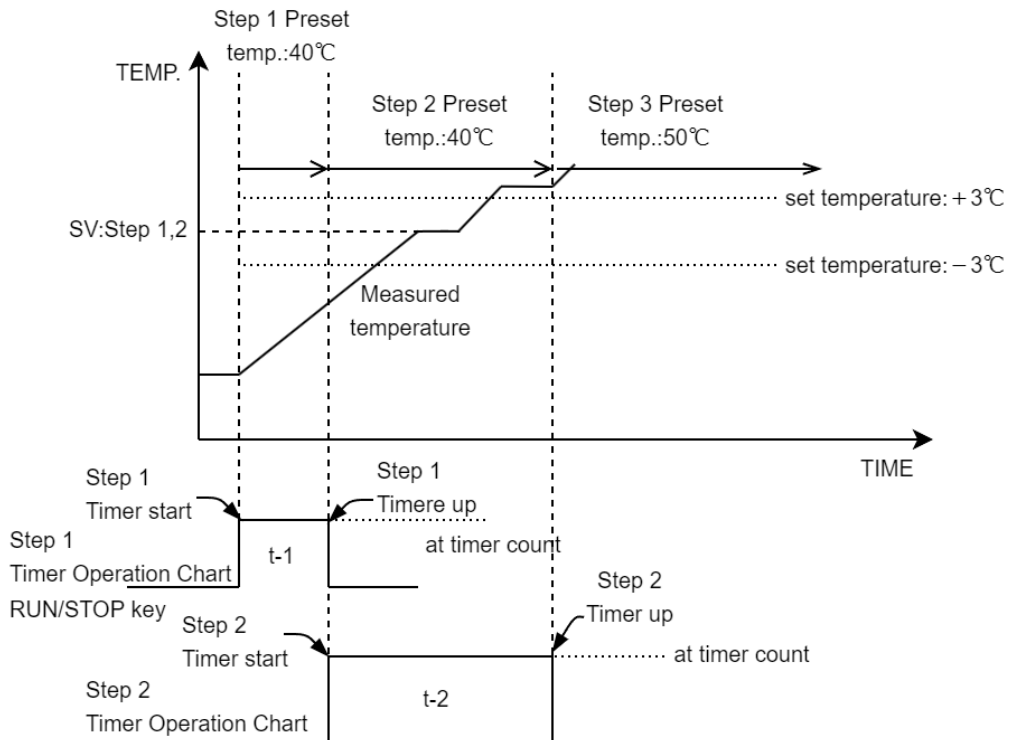

5. OPERATION PROCEDURES

Wait Function

Program step wait function setting

This section describes how to set the program step-weight function when it is used in the middle of " [Building Programs\(P.45\)](#)".

Set Wait "W_n 8_1" (n = step number) on each step according to the following procedures.

※The default setting is "on" for all steps.

- ① Enter the wait setting mode by pressing SUB MENU instead of ENTER after setting t_n (n: step number for which the weight setting is desired, character t_1, etc.) on ▲ ▼ to set the time for the step for which the weight "on" or "oFF" setting is desired.



5. OPERATION PROCEDURES

Wait Function

- ② Character W_n 8_1 (n: step number) shows in the temperature reading display, and “on” or “oFF” flashes in the temperature setting display. Use ▲ ▼ to select preferred setting.
- ③ Press SUB MENU to display PS_n for the repeat function described on the next page, and press SUB MENU again to display Pc_n for the repeat function as well.
- ④ Press SUB MENU to go on to the temperature setting of next step.



* Display cannot go back while setting Wait and Repeat functions.

5. OPERATION PROCEDURES

Repeat Function

About the Repeat Function

Program Pattern Example

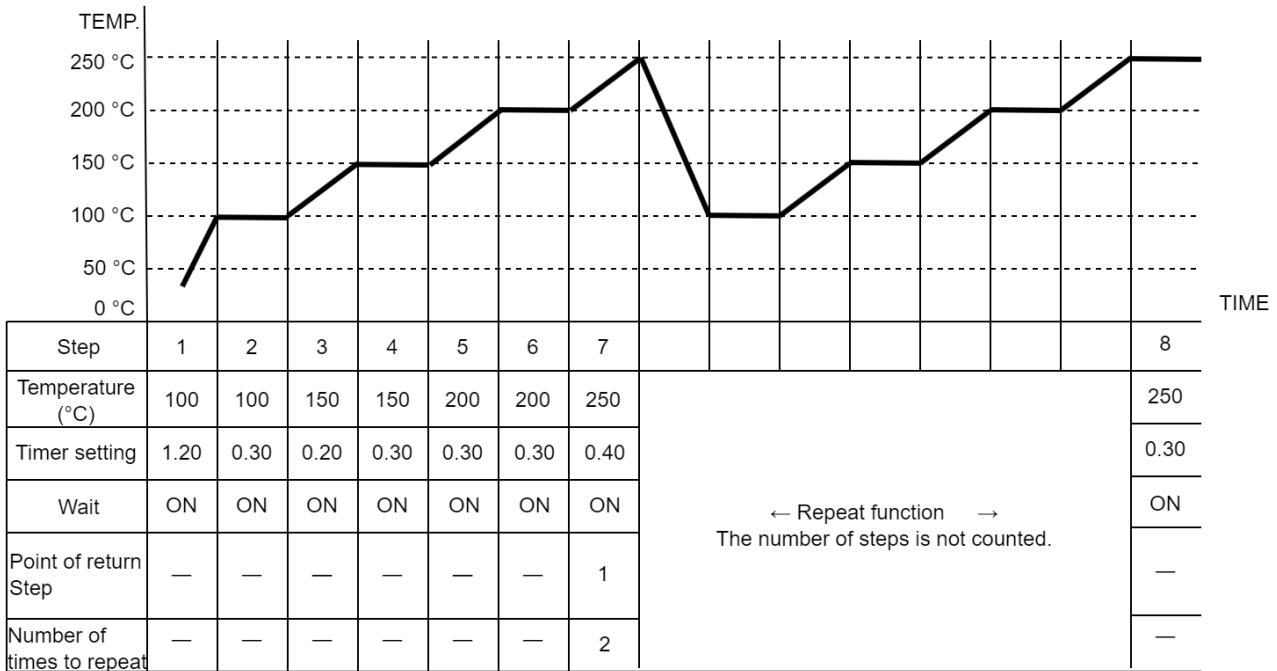

This section illustrates how to use the repeat function (repeat a program pattern) in a programmed operation.

Repeat setting



To use the repeat function in the middle of "Building Programs(P.45)" set the return destination step number "PS_n" (n: step number, character **PS-1**, etc.) and the repeat count "Pc_n" (n: step number, character **Pc-2**, etc.) by the following operations. (n: step number for repeat setting)

- After setting the time for the step for which you want to perform repeat operation (t_7 for step 7 in the reference example) at , press **SUB MENU** instead of **ENTER**. Enter the weight setting W_n described on the previous page, and press **SUB MENU** again to enter the repeat function setting mode.



5. OPERATION PROCEDURES

Repeat Function

- ② PS_n, which indicates "return destination selection" of the program pattern, is displayed on the temperature reading display. (In the reference example, the repeat function is set at the 7th step, so the temperature reading display displays **PS_7**.) Step numbers 1 to 7 can be entered into temperature setting display. Enter the number (1 in the example) using .
- ③ Press . Pc_n" indicating "number of repeats" is displayed on the temperature reading display, and the number of repeats blinks on the temperature setting display.



- ④ Set the number of repeats (2 in the reference example) at .

* When the number is "1", the step is not repeated.

- ⑤ Press  to go on to the temperature setting of next step. Temperature setting for step 8 (Sv_8) would be shown in the example above.

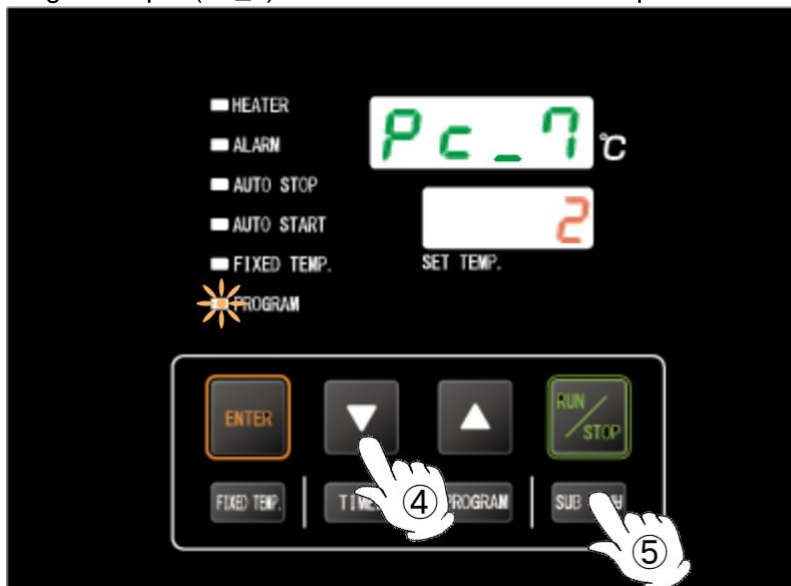

* Display cannot go back while setting Wait and Repeat functions.

5. OPERATION PROCEDURES

Do not write in this manual.
Please make copies

| | | | | | | | | |
|--------------|------|------|------|------|------|------|------------|--|
| Input into | PrG1 | PrG2 | PrG3 | PrG4 | PrG5 | PrG6 | No. | |
| Project Name | | | | | | | Date | |
| | | | | | | | Programmer | |

Input value

| | Temperature setting (°C) | Timer setting (Hours : minutes) | Wait setting (ON/OFF) | Repeat function (Point of return : number of times) |
|---------|--------------------------|---------------------------------|-----------------------|---|
| Step 1 | | | | |
| Step 2 | | | | |
| Step 3 | | | | |
| Step 4 | | | | |
| Step 5 | | | | |
| Step 6 | | | | |
| Step 7 | | | | |
| Step 8 | | | | |
| Step 9 | | | | |
| Step 10 | | | | |
| Step 11 | | | | |
| Step 12 | | | | |
| Step 13 | | | | |
| Step 14 | | | | |
| Step 15 | | | | |
| Step 16 | | | | |
| Step 17 | | | | |
| Step 18 | | | | |
| Step 19 | | | | |
| Step 20 | | | | |
| Step 21 | | | | |
| Step 22 | | | | |
| Step 23 | | | | |
| Step 24 | | | | |
| Step 25 | | | | |
| Step 26 | | | | |
| Step 27 | | | | |
| Step 28 | | | | |
| Step 29 | | | | |
| Step 30 | | | | |

5. OPERATION PROCEDURES

Calibration offset

Using calibration offset

The calibration offset function is a function that corrects the measured temperature of the controller. Offset function can correct to either the positive or negative side of the entire unit temperature range. Offset function can be set or cancelled with the SUBMENU key. Default setting is "0.0 °C", and setting range is "-15.0 to +15.0 °C"

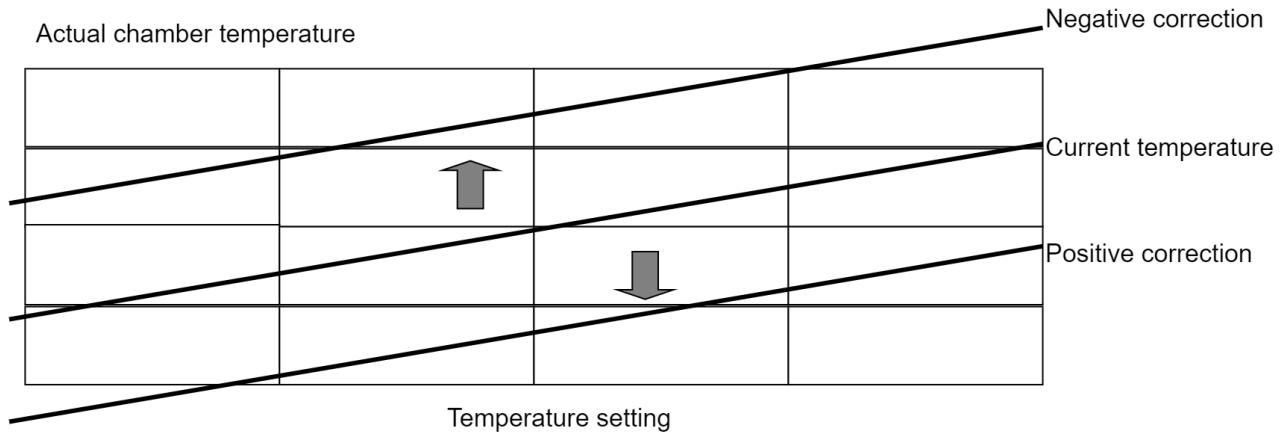

- Run unit in Fixed temperature operation. When temperature stabilizes, gauge chamber temperature with a thermograph.
- Check the differences between display temperature and chamber temperature.

① Press **SUB MENU** for about 2 seconds.

② Select **cAL** at **▲ ▼**.

③ Press **ENTER**.



5. OPERATION PROCEDURES

Calibration offset

- ④ Set the difference between the set temperature and the temperature inside the chamber at



- ⑤ Press **ENTER** or **FIXED TEMP.** to complete the setting.











- * Setting change can also be made during operation.
- * Calibration offset can be set either the positive or negative side of 0. Setting calibration offset to the negative side of 0 increases actual temperature by the negative value entered (i.e. entering a value of -3 increases actual temperature by 3°C) Setting calibration offset to the positive side of 0 decreases actual temperature by positive value entered (i.e. entering +3 decreases actual temperature by 3°C)
- * Entering excessive compensation values may cause a precariously large discrepancy between actual temperature and temperature reading.
- * In addition to the calibration offset function, this product has a temperature compensation function, which is an offset adjustment function for each temperature range, and the adjusted temperature is input at the factory.
- * Contact original dealer of purchase when it becomes necessary to validate this unit.

5. OPERATION PROCEDURES





Keypad lock

Using keypad lock

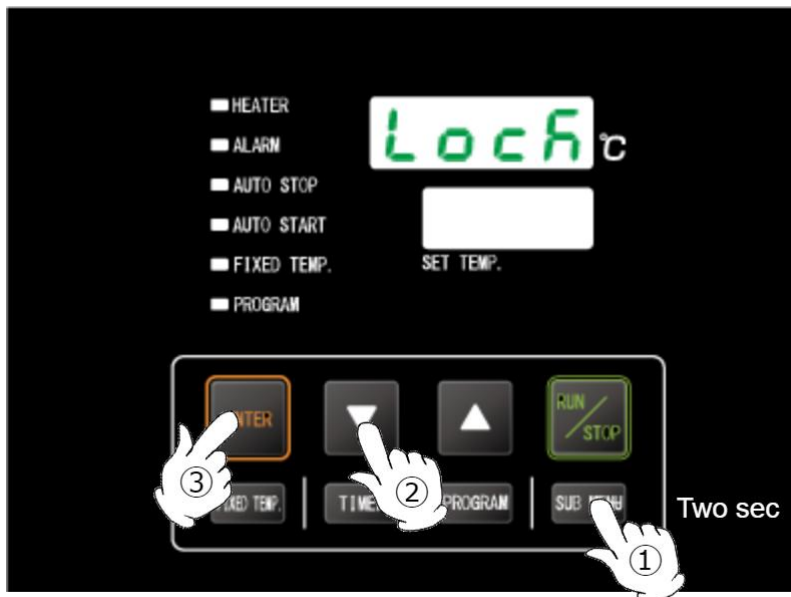
This function locks all the keys that may change setting values. When the lock function is "on", pressing any key other than  and  will display  and disable the key operation. Default setting is "oFF".

- ① Press  for about 2 seconds.
- ② Select  at  .
- ③ Press .



- ④ Center display will read "oFF" or "on". Use   to change the setting.
- ⑤ Press  or  to complete the setting. (* Setting change can also be made during operation.)

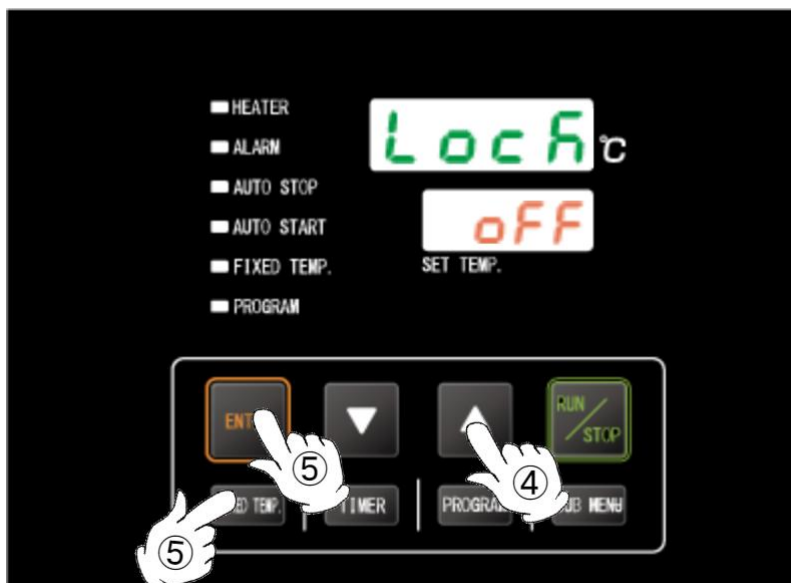

5. OPERATION PROCEDURES

Auto-resume mode select

Auto-resume mode select

Unit may restart operation or may be switched into standby state after power failure, by selecting “on” or “oFF” of this mode.

With this setting “on” unit automatically resume operation, and remain standby when set to “oFF”.

If power failure occurs during timed operation, timer will start counting again from that point when power is restored. Default setting is “on”.

*Settings cannot be changed during operation.

If you try to change the setting during operation,  will be displayed during step ④.

① Press the  key for approximately 2 seconds.

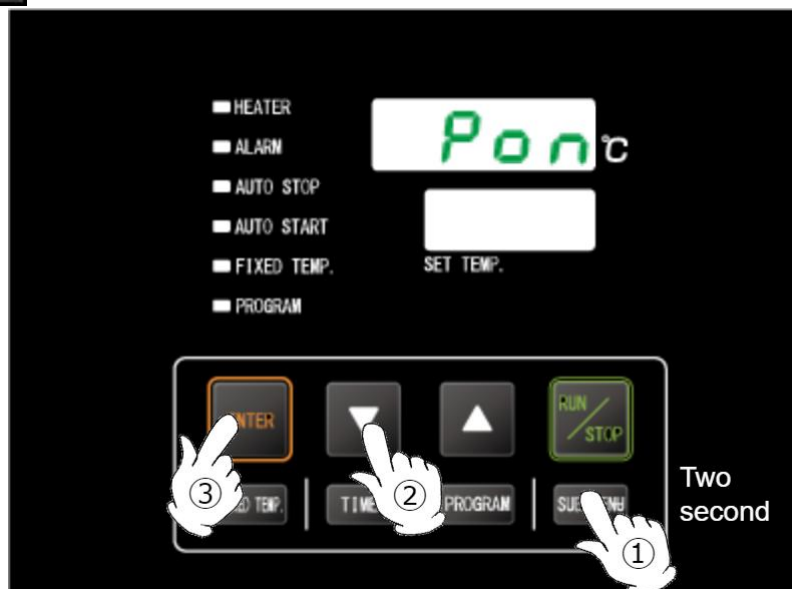

② Select  at .

③ Press the  key.



5. OPERATION PROCEDURES

Auto-resume mode select

④ Center display will read "oFF" or "on". Use   to change the setting.

⑤ Press  or  to complete the setting.

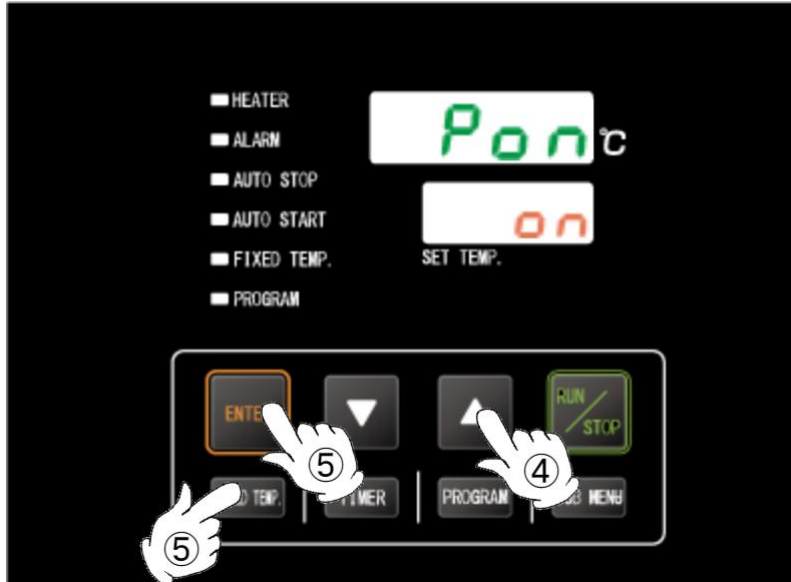

5. OPERATION PROCEDURES

Option (output terminal)

◆ Before use

| | |
|---|--|
|  | Operate this unit according to the procedure described in this Instruction manual. Failure to follow the operation procedure described herein may result in a problem. The guarantee will not apply if you operate the unit in a wrong manner. |
|---|--|

CAUTION

| | |
|---|--|
|  | 1. Turn OFF ELB before connecting the cables. |
| | 2. For Time-up output and External alarm output, ensure that the input current is no greater than contact capacity shown in the specification table. |
| | 3. Connect a recorder or another appliance of 600Ω or less in input impedance to the temperature output terminal. |
| | 4. Securely fasten all connections with the screws attached to the terminal block. |

Connection instructions

| | |
|---|---|
|  | Connect securely to the terminals to be connected. |
| | Time-up output and External alarm output are "ON" (relay contact closed) at the time of output. |
| | Use a shielded wire for the cable to be connected to prevent noise. |



| | | | | | | | |
|-------------------------|---|--------------------|---|----------------|----|-----------------------|----|
| RS-485 | | ANALOG | | TIME-UP | | ALARM | |
| A | B | + | - | COM | NO | COM | NO |
| External communications | | Temperature output | | Time-up output | | External alarm output | |

Can be selected up to four options

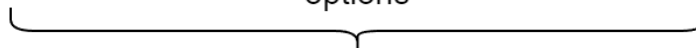

Screw terminals

The above four options can be installed together.

5. OPERATION PROCEDURES

◆ Specifications

| | |
|---|--|
| External communications terminal (RS-485) | <ul style="list-style-type: none"> Connection: M4 screw-in terminal block *See next page for overview of the standards. |
| Temperature output terminal (ANALOG) | <ul style="list-style-type: none"> Outputs the voltage (DC) corresponding to the measured temperature Output temperature range: 0 to 260 °C, this is default setting and can be changed. Output current: 4 to 20 mA Output accuracy: ±2 °C Connection: M4 screw-in terminal block |
| Time-up output pin (TIME UP) | <ul style="list-style-type: none"> The time-up time for auto-stop and quick auto-stop, and ON" output (relay contact closes) at program end. Stops output while errors occur. No-voltage a-contact (relay contact) Contact capacity; 250 V AC 3 A (resistance load) 30 V DC 3 A (resistance load) Connection: M4 screw-in terminal block <p>Ensure that the input current is no greater than contact capacity shown above.</p> |
| External alarm output terminal (ALARM) | <ul style="list-style-type: none"> Outputs "ON" signal (relay contact closed) when an error is detected. See "Reading Error Codes" (P.) for details on errors. Reading Error Codes(P.72) No-voltage a-contact (relay contact) Contact capacity; 250 V AC 3 A (resistance load) 30 V DC 3 A (resistance load) Connection: M4 screw-in terminal block <p>Ensure that the input current is no greater than contact capacity shown above.</p> |

Temperature output terminal Temperature vs. Output Current conversion table

| Temperature (°C) | Output Current (mA) | Example of voltage conversion*. |
|------------------|---------------------|---------------------------------|
| 0 | 4.0 | 1.0 |
| 65 | 8.0 | 2.0 |
| 130 | 12.0 | 3.0 |
| 195 | 16.0 | 4.0 |
| 260 | 20.0 | 5.0 |

The conversion table above is based on default output temperature range. Output temperature range can be changed.

* Temperature to current/voltage reference table for voltage input devices

Values calculated for having a shunt resistor (250Ω) connected in parallel to voltage input (V=RI:Ohm's Law)

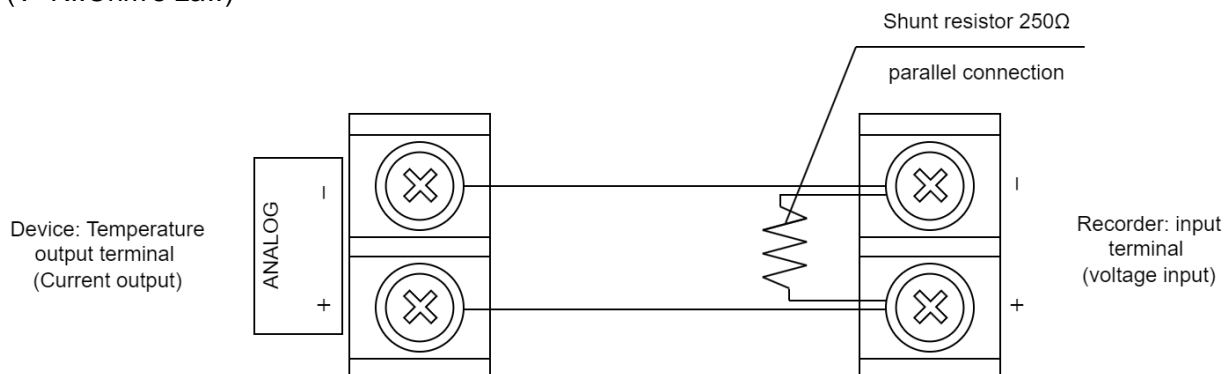

5. OPERATION PROCEDURES

Option (External output terminal)

1. Overview of communication methods

1.1 RS-485 communication

RS-485 allows to set or monitor data of the controller of this unit by building a program on host computer.

1.2 Communication Specifications

| Item | Specifications |
|----------------------------------|---|
| Communication interface standard | EIA standard RS-485 compliant |
| Synchronous method | Asynchronous communication method |
| Communication method | Two-wire half-duplex |
| Transmission code | ASC II |
| Communication rate | 2400/* 4800/9600/19200/38400bps |
| Communication range | Max. 500m (but may vary slightly depending on the surrounding environment such as cables, etc.) |
| Network | Multi-drop method (max 31 hosts to each node) |
| Stop bit length | 1/* 2 bits |
| Data length | 7/* 8-bit |
| Parity bit | * None/Odd/Even |
| Error detection | * * * Toho : BCC / Modbus-RTU : CRC-16 / Modbus-ASCII : LRC |
| Response delay time | * * 0 ~ 250msec |

Note: The * portion is the default setting of this controller.

1.3 Connection

■ PC

- USB (COM port).

■ USB/RS485 Converter

For the converter, System Sacom's USB-485 is applicable.

- Optional accessory "External communications adapter (RS485-USB) OA017" permits the following connections. (PC not included)

Sample program → <http://www.yamato-net.co.jp/support/program/index.htm>

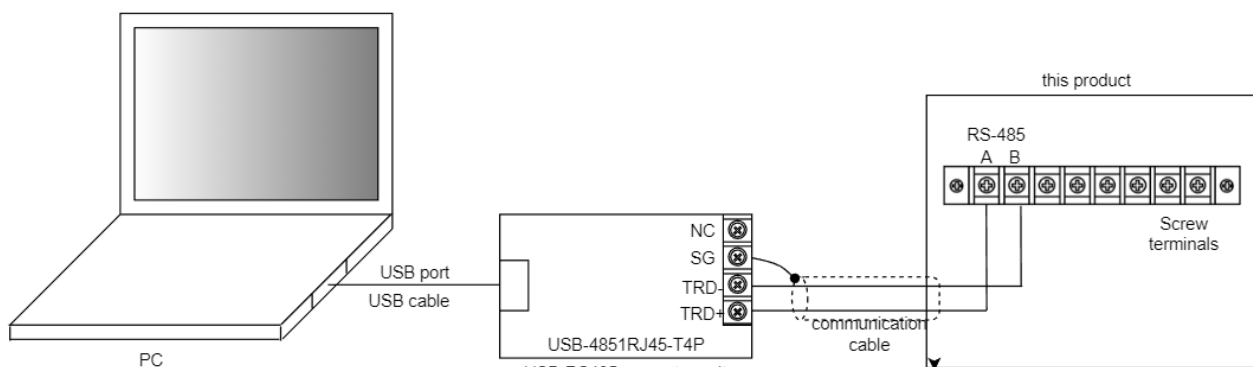

USB-RS485 converter unit: System Sacom USB-485I RJ45-T4P

Communication cable: UL2464TASB 2-lead AWG20 cable 3 m, with Y terminal on main unit side.

USB cable: 1.8 m, included with USB-485I

* It may be effective to use a commercial braided shield USB cable for noise resistance.

5. OPERATION PROCEDURES

Option (External output terminal)

1.4 Communication settings

Setting items and parameters for this controller is defined in the table below.

| | Item | Communication settings | Default values |
|---|------------------------|---|-----------------|
| 1 | Communication protocol | Toho (0)/Modbus-RTU (1)/ Modbus-ASCII (2) | Toho (0) |
| 2 | BCC check | Enable (b)/Disable (n) | Enable (b) |
| 3 | Data length | 7/8 bits | 8 bits |
| 4 | Parity bit | None (n)/odd (o)/even (E) | None (n) |
| 5 | Stop bit length | 1/2 bits | 2 bits |
| 6 | Auxiliary address | 2400 (24)/4800 (48)/ 9600 (96)/19200 (192)/ 38400 (384) bps | 4800 (48) bps |
| 7 | Auxiliary address | 1-99 units (1:31 stations at maximum) | 1 |
| 8 | Response delay time | 0-250 msec | 0 msec |
| 9 | Communication mode | Read only (ro)/ Read/Write (rW) | Read/Write (rW) |

6. MAINTENANCE PROCEDURES

MAINTENANCE PROCEDURES

Daily general maintenance and inspection is recommended to ensure optimal equipment performance.

WARNING

- Inspect regularly.
- When inspecting or maintenance, be sure to turn off earth leakage breaker OFF and disconnect the power cord from the outlet.
- Perform inspections and maintenance when unit is at room temperature.
- Never attempt to disassemble unit.

Precautions in Daily Maintenance

CAUTION

- Clean unit using soft damp cloth. Never use benzene, paint thinner, scouring powder, scrubbing brush or other abrasives and solvents to clean unit. Superficial damage and/or discoloration, as well as deformity to some components may result.
- There are sharp protrusions on the chamber interior, chamber rack, and rack support post, so be careful not to get injured.
- Working with bare hands is dangerous, so wear gloves.

Maintenance and Inspection

1. Inspect earth leakage breaker ON and OFF function.

Prepare unit for inspection by connecting power cable to a facility outlet or terminal.

- Confirm that earth leakage breaker is OFF then, turn earth leakage breaker back OFF.
- Depress the red test switch with a fine-point object, such as a ballpoint pen, etc. If power switch turns OFF without delay, it is functioning normally.

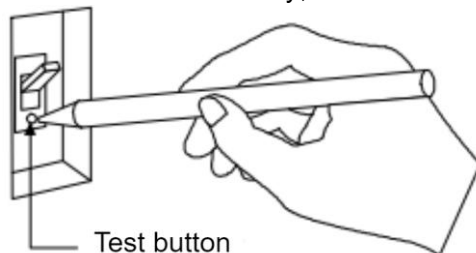

2. Check overheat prevention device.

- Set the overheat prevention device at a temperature 50 to 70°C higher than the product's set temperature.
- Operate unit in Fixed temperature mode and wait until chamber temperature becomes stable.
- Lower the overheat prevention device temperature by 10 °C.
- When the over speed protector operates normally, the heater circuit is interrupted, and at the same time the error lamp illuminates and  is displayed.

3. Check power plug for damage [DKN303/403/603]

- Check power plug for dust or dirt on its prongs. If there is dust or dirt on it, remove it.
- Confirm that the prongs of power plug are not bent or damaged. Replace if bent or damaged.
- Check the power plug for discoloration or abnormal heat generation. If there is discoloration or abnormal heating, the internal contact of the outlet may be faulty.

6. MAINTENANCE PROCEDURES

MAINTENANCE PROCEDURES

4. Check terminals at the cable end for abnormalities [DKN613]

- Visually check the terminals for dust and dirt. If there is dust or dirt on it, remove it.
- Visually check the terminals for deformation. Replace if bent or damaged.
- Check the terminals for discoloration or abnormal heat generation. If there is discoloration or abnormal heating, the internal contact of the distribution board may be faulty.
 - * ELB and overheat prevention device must be inspected, as prescribed above, prior to every instance of extended or overnight operation.

Chamber maintenance

- Stop the operation and turn OFF ELB. Disconnect power cable to appropriate facility outlet. Check the temperature inside the chamber and remove the shelf board and shelf bracket.
 - Stainless steel is used for the inside of the chamber, the shelf board, and the shelf bracket. Use a cloth soaked with alcohol for cleaning, wipe it well, and then lightly wipe it again with a dry cloth.
 - Use of acidic detergents, alkaline detergents, oils, organic solvents, etc. may cause corrosion or damage.
- ◆ Contact original dealer of purchase, if further questions arise concerning maintenance procedures.

7. EXTENDED STORAGE AND DISPOSAL

Extended Storage / Unit Disposal



WARNING

- Turn off the earth leakage breaker and remove the power plug.
- Do not leave unit in a location where children may have access



CAUTION

- Remove door handle and hinges to prevent it from locking.
- Dispose of this unit in accordance with local laws and regulations.

Dispose of or recycle this unit in a responsible and environmentally friendly manner.

Yamato Scientific Co., Ltd. strongly recommends disassembling unit, as far as is possible, in order to separate parts and recycle them in contribution to preserving the global environment. Major components and materials, comprising this unit are listed in the table below

| Component Name | Composition |
|-----------------------------|---|
| Main Unit Components | |
| Exterior | Chromium-free electrogalvanized steel sheet, baked-on finish |
| Interior | Stainless steel sheet metal |
| Heat insulator | Glass wool |
| Door gasket | Silicon rubber |
| Observation window | Tempered glass |
| Labels | Polyethylene (PET), resin film |
| Electrical Parts | |
| Switches and relays | Resin, copper |
| Circuit boards | Composite of fiber glass and other materials |
| Heater | Stainless steel |
| Power cable | Synthetic rubber coating, copper, nickel |
| Wiring material | Composites of fiber glass, fire-retardant vinyl, copper, nickel and other compounds |
| Seals | Resin material |
| Sensor | Stainless steel etc. |

8. TROUBLESHOOTING

Troubleshooting Guide

Troubles Check

| | |
|---|---|
| Unit does not activate when power is turned ON. | <ul style="list-style-type: none">● Power cable is not connected securely to power terminal or outlet.● Whether a power outage is in progress.● Is the power supply voltage not being supplied by the power supply facility or is it low? |
| Temperature does not rise. | <ul style="list-style-type: none">● Whether temperature setting is below chamber temperature.● Is the supply voltage low or unstable?● The ambient temperature is out of operable temperature range● The load in chamber is heavy |
| Temperature fluctuates during operation. | <ul style="list-style-type: none">● Temperature setting is inappropriate● Power supply voltage has dropped● Whether there are large fluctuations in external temperature.● Whether thermal load in chamber is high.● Whether the placement of the sample in the chamber appropriate.● Whether the circulation fan motor stopped. |
| Temperature reading differs from manually measured temperature | <ul style="list-style-type: none">● Calibration offset value is inappropriate.● Whether the placement of the sample in the chamber appropriate.● Power supply voltage has dropped See " Calibration offset (P.59)" and confirm calibration offset setting. |

◆If problem persists or is not applicable to any of errors above, turn off power immediately, disconnect power cable and contact original dealer of purchase for assistance.

8. TROUBLESHOOTING

Reading Error Codes

Unit has a self-diagnostic function built into the CPU board. The table below shows possible causes when safety function is triggered. If unit does not reset by turning OFF and ON ELB, contact original dealer of purchase.

[Error Codes]

When an operational error or malfunction occurs, ALARM lamp on the control panel illuminates, an error code is displayed, and an alarm sounds. Press any key to stop the alarm.

When an error occurs, confirm the error code and terminate operation immediately. For abnormal temperature reading, the controller shows only "----" on display (no lamps go on, and no alarm sounds).

| Type of alarm | Display | Contents |
|---|----------------------------------|---|
| Overheat sensor interruption or disconnection | ALARM lamp ON Er 01 on screen | <ul style="list-style-type: none"> • Failure in temperature input circuit of the controller • Disconnection of control temperature sensor |
| SSR short circuit | ALARM lamp ON Er 02 on screen | <ul style="list-style-type: none"> • Short circuit in SSR |
| Heater line disconnection | ALARM lamp ON Er 03 on screen | <ul style="list-style-type: none"> • Heater interruption or disconnection • Current sensing element failure, disconnection • Drop in power supply voltage • Failure of main relay |
| Overheating | ALARM lamp ON Er 07 on screen | <ul style="list-style-type: none"> • Independent overheat prevention device activated <p>*Check the temperature setting</p> |
| Main relay contact short circuit | ALARM lamp ON Er 10 on screen | <ul style="list-style-type: none"> • Main relay contact short circuit |
| Memory error | ALARM lamp ON Er 15 on screen | <ul style="list-style-type: none"> • Error in CPU storage setting on the controller. |
| Internal communication error | ALARM lamp ON Er 17 on screen | <ul style="list-style-type: none"> • Internal communication error, temperature input circuit failure |
| Abnormal temperature reading | ---- on screen | <ul style="list-style-type: none"> • Temperature reading is out of display range (-10 to 1310 °C) |

9. SERVICE & REPAIR

Requests for Repair

Warranty card (attached separately)

Warranty card will be handed by dealer or Yamato personnel upon delivery and installation, or will be attached to equipment if no one from dealer or Yamato is to be present at delivery and installation.

Register warranty card at <https://www.yamato-net.co.jp/support/warranty.htm>

<https://www.yamato-net.co.jp/support/warranty.htm>

- Keep warranty card safe.

Requests for Repair

If abnormalities remain after confirming "Troubleshooting Guide", terminate operation, turn off power, and disconnect power cable. Contact original dealer of purchase or Yamato sales office for assistance.

The following information is required for all repairs.

- Product Name
 - Model
 - Serial Number
 - Date (year/month/day) of Delivery
 - Description of problem in as much detail as possible
 - Repair this equipment for free of charge according to the contents on warranty card.
Warranty period is 1 (one) year from date of purchase.
 - Consult with original dealer of purchase or Yamato sales office for any repair after warranty ended. Charged repair service of this equipment will be available on customer's request when it can be maintained functional by its repair.
- } Refer to warranty card.

*Be sure to present warranty card to the service representative.

Guaranteed Supply Period for Repair Parts

Guaranteed maximum supply period for repair parts is 7 (seven) years from date of discontinuation for this equipment.

"Repair parts" is defined as components which, when installed, allow for continued equipment operation.

10. SPECIFICATIONS

| Model | DKN303 | DKN403 | DKN603 | DKN613 |
|--|--|---|-----------------------------------|-----------------------------------|
| Product code | 213010 | 213011 | 213012 | 213013 |
| System | Forced convection | | | |
| Operating ambient temperature range | 5 to 35 °C | | | |
| Temperature setting range | 0 to 260 °C | | 0 to 250 °C | 0 to 260 °C |
| Performance *1*2 | | | | |
| Temperature control range | Room temperature +10 °C to 260 °C | | Room temperature +10 °C to 250 °C | Room temperature +10 °C to 260 °C |
| Temperature fluctuation (JIS C 60068-3-5:2020) | ±0.4 °C(at260 °C)* | ±0.6 °C(at260 °C)* | ±0.8 °C(at250 °C)* | ±0.7 °C(at260 °C)* |
| Temperature gradient (JIS C 60068-3-5 : 2020) | 9 °C(at260 °C)* | 10 °C(at260 °C)* | 9 °C(at250 °C)* | 9 °C(at260 °C)* |
| Temperature rise rate (JIS C 60068-3-5 : 2020) | 3.9 °C/min | 2.6 °C/min | 2.1 °C/min | 3.0 °C/min |
| Temperature rise time (reference)(room temperature to 260(250) °C) | Approx. 60 min. | Approx. 90 minutes | Approx. 120 minutes | Approx. 80 minutes |
| Configuration | | | | |
| Exterior | Chromium-free electrogalvanized steel sheet, baked coating | | | |
| Chamber | Stainless steel sheet metal | | | |
| Heat insulator | Glass wool | | | |
| Heater | Stainless steel tube heater | | | |
| | 0.8kW | 1.2 kW | 1.34 kW | 1.5kW |
| Blower fan/ | MotorSirocco fan(1) / Capacitor motor | | | |
| Cable port | 33 mm I.D. (right side (1)) | | | |
| Exhaust port | 33 mm I.D. (ceiling (2)) | | | |
| Observation window | 180 x 180 mm chemically strengthened glass x 3 pieces | 250 x 280 mm chemically strengthened glass x 3 pieces | | |
| Safety devices | | | | |
| Safety devices | Self-diagnostic functions (Automatic over-temperature protection, Temperature sensor failure, Heater disconnection, SSR short circuit, Main relay failure, Memory error, Internal communication error, Abnormal temperature reading) / Independent over-temperature protection / Set value lock function / Overcurrent leakage breaker | | | |
| Controller | | | | |
| Temperature control system | PID control by microcomputer | | | |
| Setting system | Digital setting method using dedicated menu keys and ▲▼ keys | | | |
| Display system | Temperature reading display: Green 4-digit LED digital display / Temperature setting display: Red 4-digit LED digital display | | | |
| Temperature resolution | 1 °C | | | |
| Timer | 0 minutes to 99 hours 59 minutes and 100 to 999 hours 50 minutes (with timer wait function, ON/OFF possible) | | | |
| Timer resolution | 1 minute increments under 999 hours and 59 minutes, 10 minutes after 100 hours. | | | |
| Weight function | Timer wait function (ON/OFF setting) | | | |
| Operation modes | Fixed temperature/Program operation/Quick auto stop operations/Auto stop operation/Auto start operation/Program auto start | | | |
| Additional functions | Calibration offset / Keypad lock / Auto-resume mode select | | | |
| Sensor | Temperature regulator: K thermocouple For independent oversurge prevention: Hydraulic oversurge prevention | | | |

10. SPECIFICATIONS

| Model | DKN303 | DKN403 | DKN603 | DKN613 |
|--|---|-----------------|-----------------|--------------------------|
| Standard | | | | |
| Internal dimensions (W x D x H) mm | 300 x 300 x 300 | 450 x 450 x 450 | 600 x 500 x 500 | |
| External dimensions (W x D x H) mm *3 | 410 x 450 x 670 | 560 x 600 x 820 | 410 x 450 x 670 | |
| Internal volume (L) | 27 L | 90 L | 150 L | |
| Number of tiers/rack support pitch | 6 tiers/30 mm | 11 tiers/30 mm | 13 tiers/30 mm | |
| Chamber rack load capacity | 15 kg/rack, total load capacity 30 kg | | | |
| Power supply (50/60 Hz), Rated current | AC115V 7.5A | AC115V 11A | AC115V12A | Single phase AC220V 7.5A |
| Approx. weight | Approx. 35 kg | Approx. 50 kg | Approx. 70 kg | Approx. 71 kg |
| Breaker capacity | 15 A | | | |
| Accessories | | | | |
| Chamber rack | Perforated stainless steel plate | | | |
| Number of racks/rack supports | 1 piece/2 pcs (separately, bottom shelf is fixed in the tank) | | | |
| Instruction Manual | 1 pcs | | | |
| Warranty card | 1 | | | |
| Optional | | | | |
| Stand | OA115(281353) | - | - | - |
| | - | OA116 (281354) | | |
| | - | OA117 (281355) | - | - |
| | - | - | OA118 (281356) | |
| Stacking Hardware | - | OA119(281357) | - | - |
| | - | - | OA120(281358) | |
| Chamber Rack (perforated stainless steel(1) / supports(2)) | ●(212068) | - | - | - |
| | - | ●(212246) | - | - |
| | - | - | ●(212266) | |
| Cable hole (inner diameter 25 mm) | ODK32(281121) | | | |
| Cable hole (inner diameter 50 mm) | ODK34(281122) | | | |
| Temperature output terminal (4-20 mA) | OA137(281375) | | | |
| Remote Communications Terminal (RS485) | OA140(281378) | | | |
| External communication adapter (RS485-USB conversion) | OA017(281146) | | | |
| External alarm output terminal *4 | OA138(281376) | | | - |
| | - | - | - | OA141(281379) |
| Time-up Output Terminal *4 | OA139(281377) | | | - |
| | - | - | - | OA142(281380) |
| Seismic mat "Labopita" | -(296902) | | | |
| Sheath sensor | ODT48 | | | |
| Silicon Plug (with hole) | ODT52(212947) | | | |

*1. Performance (excluding temperature rise time) is based on a power supply of 115 VAC or 220 VAC, room temperature of 23°C±5°C, humidity of 65%RH±20%, and no load.

Note that the maximum temperature in the temperature control range (260°C) may not be reached if the power supply voltage is below 115 V or 220 V or if the outside temperature is low.

10. SPECIFICATIONS

*2. Temperature rise time is reference data at 115 VAC or 220 VAC, room temperature 23°C, humidity 65%, and no load.

Note that if the power supply voltage is below 115V or 220V or if the outside temperature is low, the temperature rise time may be extended.

*3. Dimensions do not include protrusions.

*4. Time-up output and external alarm output terminals can be selected simultaneously.

*5. For product improvement, above specifications are subject to change without notice.

11. OPTIONAL ACCESSORIES

List of Options

◆ Available for installation after delivery

| Product name | Product code | Model | Compatible models | Description |
|--|--------------|-------|--------------------|---|
| Stand | 281353 | OA115 | DKN303 | Unit can be secured on this stand with screws. (casterless) |
| | 281354 | OA116 | DKN403/603/613 | |
| | 281355 | OA117 | DKN403 | |
| | 281356 | OA118 | DKN603/603 | |
| Stacking Hardware | 281357 | OA119 | DKN403 | For use to stack a DKN403 unit on another. |
| | 281358 | OA120 | DKN603/613 | For use to stack a DN603/613 unit on another. |
| Chamber Rack (perforated stainless steel(1) / supports(2)) | 212068 | — | DKN303 | Same as standard racks; available for additional purchase. |
| | 212246 | — | DKN403 | |
| | 212266 | — | DKN603/613 | |
| Temperature output terminal (4-20 mA) | 281375 | OA137 | DKN303/403/603/613 | |
| External Alarm Terminal | 281376 | OA138 | DKN303/403/603 | |
| | 281379 | OA141 | DKN613 | |
| Time-up Output Terminal | 281377 | OA139 | DKN303/403/603 | |
| | 281380 | OA142 | DKN613 | |
| Remote Communications Terminal (RS485) | 281378 | OA140 | DKN303/403/603/613 | |
| External communications adaptor kit (RS485-USB conversion) | 281146 | OA017 | DKN303/403/603/613 | |
| Seismic mat "Labopita" | 296902 | — | DKN303/403/603/613 | For use to prevent unit from falling or tipping. |
| Sheath Sensor (K thermocouple) | 212946 | ODT48 | | |
| Silicon Plug | 212947 | ODT52 | | |

◆ Not available for installation after delivery

| Product name | Product code | Model | Compatible models | Description |
|-----------------------------------|--------------|-------|--------------------|---|
| Cable hole (inner diameter 25 mm) | 281121 | ODK32 | DKN303/403/603/613 | Please contact us for installation position and quantity. |
| Cable hole (inner diameter 50 mm) | 281122 | ODK34 | DKN303/403/603/613 | |

12. LIST OF HAZARDOUS SUBSTANCES



Never attempt to process explosives, flammables or any items which contain explosives or flammables.

List of hazardous substances

| Explosive substances |
|--|
| ① Nitroglycol, Glycerine Trinitrate, Cellulose Nitrate and other explosive nitrate esters |
| ② Trinitrobenzen, Trinitrotoluene, Picric Acid and other explosive nitro compounds |
| ③ Acetyl Hydroperoxide, Methyl Ethyl Ketone Peroxide, Benzoyl Peroxide and other organic peroxides |
| ④ Metallic Azide, including Sodium Azide, etc. |
| Combustible substances |
| ①Metal "Lithium" ②Metal "Potassium" ③Metal "Natrium" ④Yellow Phosphorus ⑤Phosphorus Sulfide ⑥Red Phosphorus ⑦Phosphorus Sulfide ⑧Celluloids, Calcium Carbide (a.k.a, Carbide) ⑨ Lime Phosphide ⑩Magnesium Powder ⑪Aluminum Powder ⑫Metal Powder other than Magnesium and Aluminum Powder ⑬Sodium Dithionous Acid (a.k.a., Hydrosulphite) |
| Oxidizing substances |
| ① Potassium Chlorate, Sodium Chlorate, Ammonium Chlorate, and other chlorates |
| ② Potassium Perchlorate, Sodium Perchlorate, Ammonium Perchlorate, and other perchlorates |
| ③ Potassium Peroxide, Sodium Peroxide, Barium Peroxide, and other inorganic peroxides |
| ④ Potassium Nitrate, Sodium Nitrate, Ammonium Nitrate, and other nitrates |
| ⑤ Sodium Chlorite and other chlorites |
| ⑥ Calcium Hypochlorite and other hypochlorites |
| Flammable substances |
| ① Ethyl Ether, Gasoline, Acetaldehyde, Propylene Chloride, Carbon Disulfide, and other substances having ignition point of 30 or more degrees below zero. |
| ② n-hexane, Ethylene Oxide, Acetone, Benzene, Methyl Ethyl Ketone and other substances with ignition point between 30 degrees below zero and less than zero. |
| ③ Methanol, Ethanol, Xylene, Pentyl n-acetate, (a.k.a. amyl n-acetate) and other substances having ignition point of between zero and less than 30 degrees. |
| ④ Kerosene, Light Oil, Terebinth Oil, Isopenthyll Alcohol (a.k.a. Isoamyl Alcohol), Acetic Acid and other substances having ignition point of between 30 degrees and less than 65 degrees. |
| Combustible gas |
| Hydrogen, Acetylene, Ethylene, Methane, Ethane, Propane, Butane and other gases combustible at 15°C, ambient air pressure. |

13. STANDARD INSTALLATION MANUAL

* Please install according to the following items. (Please check separately for options and special specifications)

| Model | Serial Number | Installation Date | Installation proved by (Company name) | Installation proved by | Judgment |
|-------|---------------|-------------------|--|------------------------|----------|
| | | | | | |

| No. | Item | Implementation method | Reference page of instruction manual | Judgment |
|----------------------------------|---|--|---|----------|
| Specifications | | | | |
| 1 | Accessories | Quantity check according to the accessories column | 10. SPECIFICATIONS(P.74) | |
| 2 | Installation | <ul style="list-style-type: none"> Visual check of surrounding conditions Caution: Take care for environment Securing a space | 3. PRE-OPERATION PROCEDURES Installation Precautions(P.15) | |
| | | -Installing chamber racks | 4. PRE-OPERATIVE PREPARATIONS Chamber Rack Placement(P.18) | |
| Operation-related matters | | | | |
| 1 | Power supply voltage | <ul style="list-style-type: none"> Customer voltage with tester Measure (outlet, etc.) Measure line voltage during operation (must meet required voltage) Caution: Use a compliant plug to install | 1. SAFETY PRECAUTIONS Ground wire MUST be connected properly (P.8) 3. PRE-OPERATION PROCEDURES Always connect power cable to appropriate facility outlet or terminal.(P.16) 10. SPECIFICATIONS(P.74) | |
| 2 | Confirmation on operation | Explain name and function of each component. | 2. COMPONENT NAMES AND FUNCTIONS 本体 DKN303/403/603/613(P.11) Controller(P.13) | |
| Description | | | | |
| 1 | Operational descriptions | Explain operations of each component and handling precautions according to instruction manual. | 5. OPERATION PROCEDURES(P.25) 1. SAFETY PRECAUTIONS(P.3) ~12. LIST OF HAZARDOUS SUBSTANCES(P.78) | |
| 2 | Error Codes | Explain about error codes and procedures for reset according to instruction manual. | 8. TROUBLESHOOTING(P.71) ~9. SERVICE & REPAIR(P.73) | |
| 3 | Maintenance and Inspection | Explain about maintenance of equipment and each component according to instruction manual. | 6. MAINTENANCE PROCEDURES(P.68) | |
| 4 | Completion of installation Matters to be Stated | <ul style="list-style-type: none"> Enter the date of installation and name of the charged personnel in the main unit nameplate. Fill in necessary information to warranty card and hand it over to customer Explain how to contact with service personnel | 9. SERVICE & REPAIR(P.73) | |

Limited Liability

Always operate equipment in strict compliance to the handling and operation procedures set forth by this instruction manual.

Yamato Scientific Co., Ltd. assumes no responsibility for malfunction, damage, injury or death resulting from negligent equipment use.

Never attempt to disassemble, repair or perform any procedure which are not expressly mandated by this manual.

Doing so may result in equipment malfunction, serious personal injury or death.

Notice

- Instruction manual descriptions and specifications are subject to change without notice.
- Yamato Scientific Co., Ltd. will replace flawed instruction manuals (pages missing, pages out of order, etc.) upon request.

Instruction Manual
Forced Convection Constant Temperature Oven
DKN303/403/603/613
First Edition: December 24, 2025
Revised:

Yamato Scientific Co., Ltd.
Harumi Triton Square Office Tower Y (36F)
1-8-11 Harumi, Chuo-ku, Tokyo 104-6136, JAPAN

For repair service, maintenance service and consumables purchase support, please contact to our distributors from whom you purchased.

Or please visit to our customer support website at
<https://www.yamato-scientific.com/support/inquiry/>

Yamato Scientific America Inc.
2040 CORPORATE COURT
SAN JOSE, CA 95131, U.S.A
<http://www.yamato-usa.com>
Toll Free: 1-800-2-YAMATO(1-800-292-6286)